

# ALUMINUM STEP STAND - SSA-2-Y

APPROX WEIGHT: 13.98 lbs.  
 DOES NOT INCLUDE WEIGHT OF POWER OR PACKAGING!!!

\*\*\* ANY ADDITIONS, DELETIONS, OR OMISSIONS MUST BE CORRECTED ON THIS DRAWING AS THIS DRAWING WILL BE CONSIDERED ALL INCLUSIVE \*\*\*

ALL GRAPHICS PROVIDED ARE FOR REFERENCE ONLY. IF CERTAIN DIMENSIONS ARE CRITICAL PLEASE VERIFY THOSE DIMENSIONS WITH YOUR SALESPERSON

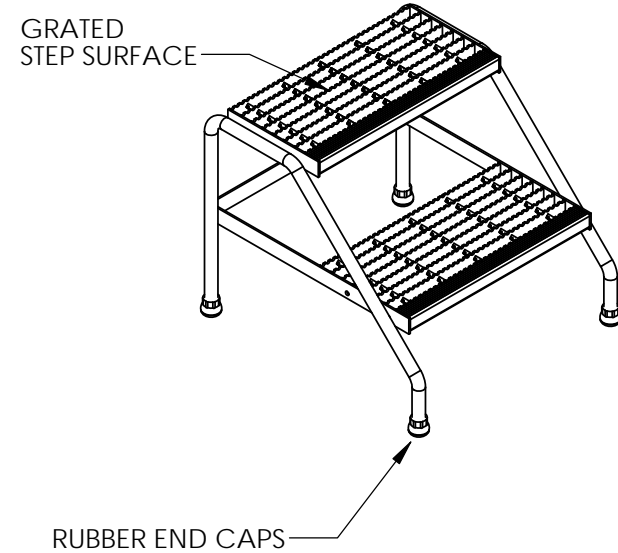
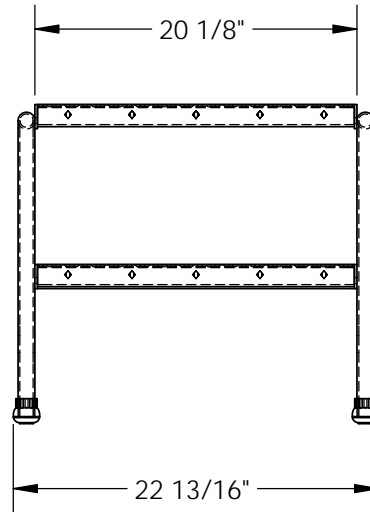
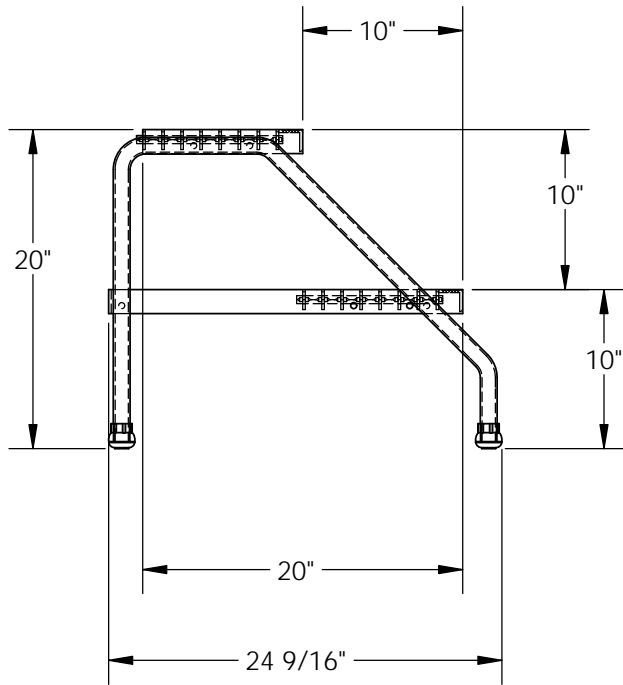

## STANDARD FEATURES

MODEL NUMBER IS SSA-2-Y  
 DOUBLE STEP UNIT  
 OVERALL WIDTH IS 22 13/16"  
 USEABLE WIDTH IS 20 1/8"  
 OVERALL LENGTH IS 24 9/16"  
 USEABLE LENGTH IS 20"  
 OVERALL HEIGHT IS 20"  
 MAX CAPACITY IS 500 LBS  
 YELLOW POWDER COAT FINISH

## SPECIAL FEATURES

NONE

DIMENSION TOLERANCE ± 1/4"

<b>APPROVAL</b>	I, THE UNDERSIGNED, AGREE THAT THE PRODUCT AS REPRESENTED SATISFIES DESIGN AND DIMENSION REQUIREMENTS. I ALSO ACKNOWLEDGE MY DUTY TO CONFIRM PRODUCT AND INSTALLATION COMPLIANCE WITH ALL APPLICABLE FEDERAL, STATE AND LOCAL REGULATIONS AND STANDARDS.	
	<b>ALL SPECIAL UNITS ARE NON-RETURNABLE</b> <input type="checkbox"/> As drawn <input type="checkbox"/> As marked	
	Signed: _____	Date: _____
<b>LEAD TIME WILL START UPON RECEIPT OF SIGNED APPROVAL DRAWING</b>		

FOR INTERNAL USE ONLY PROJECT SIGN OFF	
SALES	
ENG.	
FAB.	
POWER	

DISTRIBUTOR'S NAME:		P.O.#
VESTIL MANUFACTURING		X
DRAWN BY:	DATE:	W.O.#
BCN	2/8/2016	X
REFERENCE:	SCALE:	SALES:
X	1:12	X
QUOTED LEAD TIME:	QUOTE #	FILE NAME:
X	X	44-007-212-001