

TOW BAR PACKAGE - ALL-TTB

APPROX WEIGHT: 14.61 lbs.
DOES NOT INCLUDE WEIGHT OF POWER OR PACKAGING!!!

*** ANY ADDITIONS, DELETIONS, OR OMISSIONS MUST BE CORRECTED ON THIS DRAWING AS THIS DRAWING WILL BE CONSIDERED ALL INCLUSIVE ***

ALL GRAPHICS PROVIDED ARE FOR REFERENCE ONLY. IF CERTAIN DIMENSIONS ARE CRITICAL PLEASE VERIFY THOSE DIMENSIONS WITH YOUR SALESPERSON

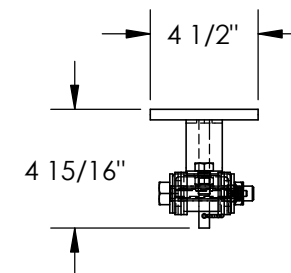
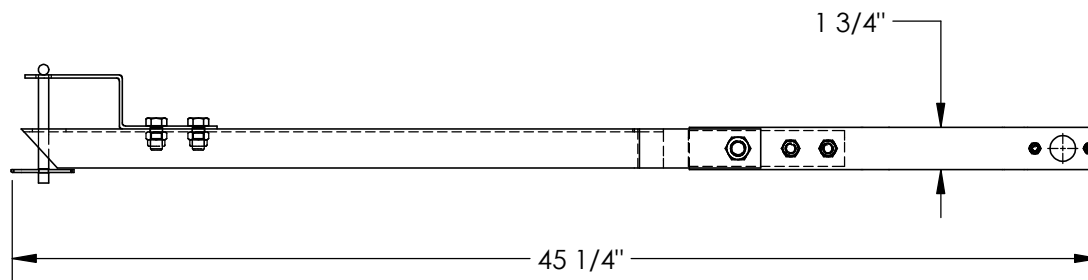
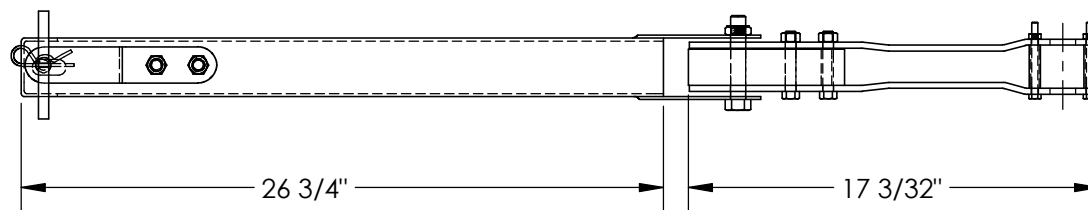
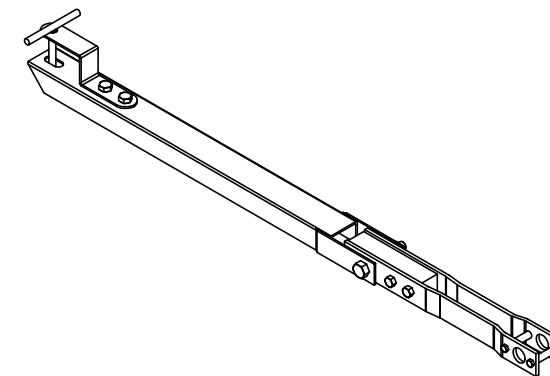

DIMENSION TOLERANCE $\pm 1/2$ "

STANDARD FEATURES

- MODEL NUMBER IS: ALL-TTB
- OVERALL WIDTH IS: 4 1/2"
- OVERALL LENGTH IS: 45 1/4"
- OVERALL HEIGHT IS: 4 15/16"
- STRAP NOT SHOWN
- STRAP IS NOT FOR TOWING BUT TO HOLD TOWBAR WHILE NOT IN USE

SPECIAL FEATURES

NONE

A P P R O V A L	I, THE UNDERSIGNED, AGREE THAT THE PRODUCT AS REPRESENTED SATISFIES DESIGN AND DIMENSION REQUIREMENTS. I ALSO ACKNOWLEDGE MY DUTY TO CONFIRM PRODUCT AND INSTALLATION COMPLIANCE WITH ALL APPLICABLE FEDERAL, STATE AND LOCAL REGULATIONS AND STANDARDS.	
	ALL SPECIAL UNITS ARE NON-RETURNABLE [] As drawn [] As marked	
Signed: _____		Date: _____
LEAD TIME WILL START UPON RECEIPT OF SIGNED APPROVAL DRAWING		

FOR INTERNAL USE ONLY PROJECT SIGN OFF	
SALES	
ENG.	
FAB.	
POWER	

DISTRIBUTOR'S NAME:		P.O.#
VESTIL MANUFACTURING		X
DRAWN BY:	DATE:	W.O.#
ALH	6/3/11	X
REFERENCE:	SCALE:	FILE NAME:
X	1:8	15-007-117
QUOTED LEAD TIME:	QUOTE #	
X	X	