

ERGO-HANDLE WHEEL CHOCK - FAB-10-ERGO

APPROX WEIGHT: 11.77 lbs.
DOES NOT INCLUDE WEIGHT OF POWER OR PACKAGING!!!

*** ANY ADDITIONS, DELETIONS, OR OMISSIONS MUST BE CORRECTED ON THIS DRAWING AS THIS DRAWING WILL BE CONSIDERED ALL INCLUSIVE ***

ALL GRAPHICS PROVIDED ARE FOR REFERENCE ONLY. IF CERTAIN DIMENSIONS ARE CRITICAL PLEASE VERIFY THOSE DIMENSIONS WITH YOUR SALESPERSON

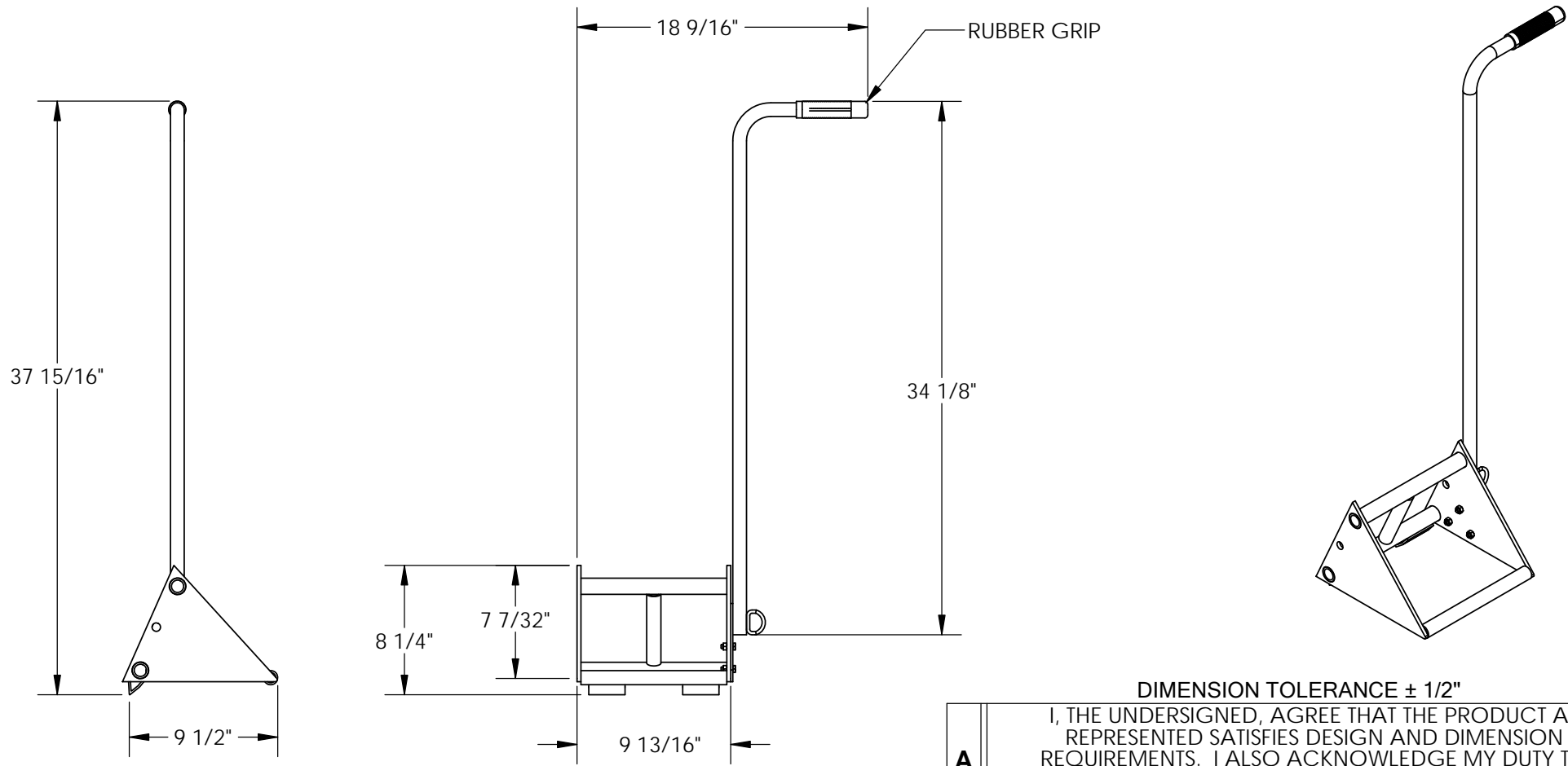

STANDARD FEATURES

- MODEL NUMBER IS FAB-10-ERGO
- CHOCK WIDTH IS $9 \frac{13}{16}$ "
- OVERALL WIDTH IS $18 \frac{9}{16}$ "
- CHOCK LENGTH IS $9 \frac{1}{2}$ "
- OVERALL HEIGHT IS $37 \frac{15}{16}$ "
- CHOCK HEIGHT IS $7 \frac{7}{32}$ "
- HANDLE COMES WITH RUBBER GRIP
- SHIPS KNOCKED DOWN
- 10' CHAIN INCLUDED (NOT SHOWN)

SPECIAL FEATURES

NONE

DIMENSION TOLERANCE $\pm 1/2$ "

APPROVAL	I, THE UNDERSIGNED, AGREE THAT THE PRODUCT AS REPRESENTED SATISFIES DESIGN AND DIMENSION REQUIREMENTS. I ALSO ACKNOWLEDGE MY DUTY TO CONFIRM PRODUCT AND INSTALLATION COMPLIANCE WITH ALL APPLICABLE FEDERAL, STATE AND LOCAL REGULATIONS AND STANDARDS.	
	ANY MODIFIED UNITS ARE NON-RETURNABLE	
	[] As drawn [] As marked	
	Signed: _____	Date: _____
Printed Name: _____		
LEAD TIME WILL START UPON RECEIPT OF SIGNED APPROVAL DRAWING		

FOR INTERNAL USE ONLY PROJECT SIGN OFF	
SALES	
ENG.	
FAB.	
POWER	

DISTRIBUTOR'S NAME:		P.O.#
VESTIL MANUFACTURING		X
DRAWN BY: R. STOY		DATE: 09/07/2012
REFERENCE: X		SCALE: 1:10
QUOTED LEAD TIME: X		QUOTE #
		X
		FILE NAME:
		23-007-450