

STAINLESS STEEL BUCKET - MODEL: BKT-SS-500

APPROX WEIGHT: 6.70 lbs.
 DOES NOT INCLUDE WEIGHT OF POWER OR PACKAGING!!!

*** ANY ADDITIONS, DELETIONS, OR OMISSIONS MUST BE CORRECTED ON THIS DRAWING AS THIS DRAWING WILL BE CONSIDERED ALL INCLUSIVE ***

ALL GRAPHICS PROVIDED ARE FOR REFERENCE ONLY. IF CERTAIN DIMENSIONS ARE CRITICAL PLEASE VERIFY THOSE DIMENSIONS WITH YOUR SALESPERSON

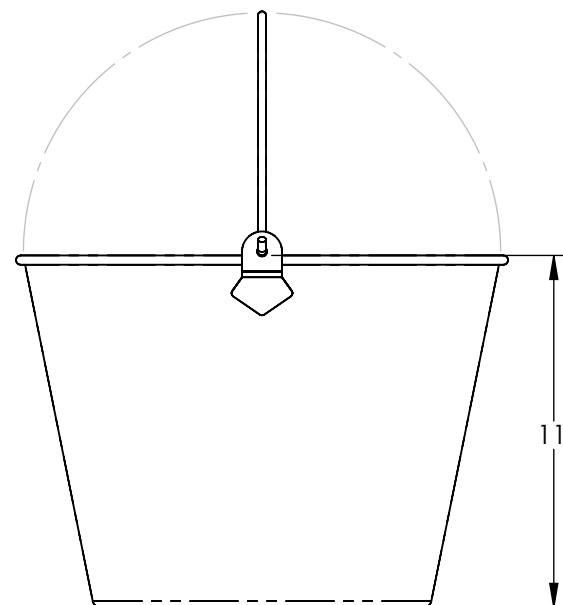
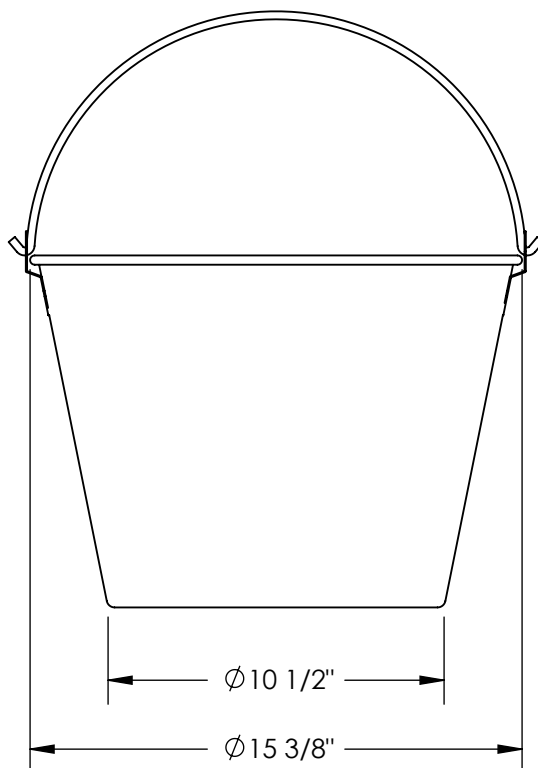

STANDARD FEATURES

MODEL NUMBER IS: BKT-SS-500
 OVERALL SMALL DIAMETER IS: 10 1/2"
 OVERALL LARGE DIAMETER IS: 15 3/8"
 OVERALL HEIGHT IS: 11"
 MAX VOLUME IS: 6.5 GALLONS OR 24.6 LITERS

SPECIAL FEATURES

NONE

APPROVAL	I, THE UNDERSIGNED, AGREE THAT THE PRODUCT AS REPRESENTED SATISFIES DESIGN AND DIMENSION REQUIREMENTS. I ALSO ACKNOWLEDGE MY DUTY TO CONFIRM PRODUCT AND INSTALLATION COMPLIANCE WITH ALL APPLICABLE FEDERAL, STATE AND LOCAL REGULATIONS AND STANDARDS. ALL SPECIAL UNITS ARE NON-RETURNABLE [] As drawn [] As marked	
	Signed: _____ Date: _____ LEAD TIME WILL START UPON RECEIPT OF SIGNED APPROVAL DRAWING	

DISTRIBUTOR'S NAME:		P.O.#
VESTIL MANUFACTURING		X
DRAWN BY:		W.O.#
J. RIDLEY	DATE:	X
	02/10/09	SALES:
	SCALE: 1:6	X
REFERENCE:	QUOTE #	FILE NAME:
X	X	30-007-878