

ROLL-OUT BASE - MTC-RB

APPROX WEIGHT: 57.44 lbs.
 DOES NOT INCLUDE WEIGHT OF POWER OR PACKAGING!!!

*** ANY ADDITIONS, DELETIONS, OR OMISSIONS MUST BE CORRECTED ON THIS DRAWING AS THIS DRAWING WILL BE CONSIDERED ALL INCLUSIVE ***

ALL GRAPHICS PROVIDED ARE FOR REFERENCE ONLY. IF CERTAIN DIMENSIONS ARE CRITICAL PLEASE VERIFY THOSE DIMENSIONS WITH YOUR SALESPERSON

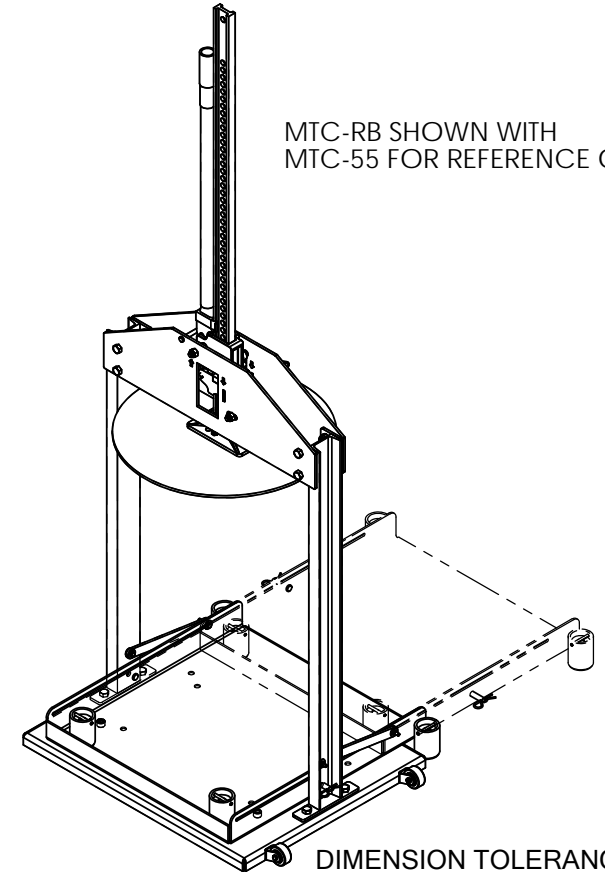
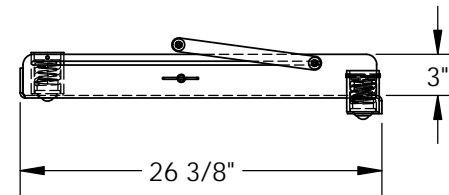
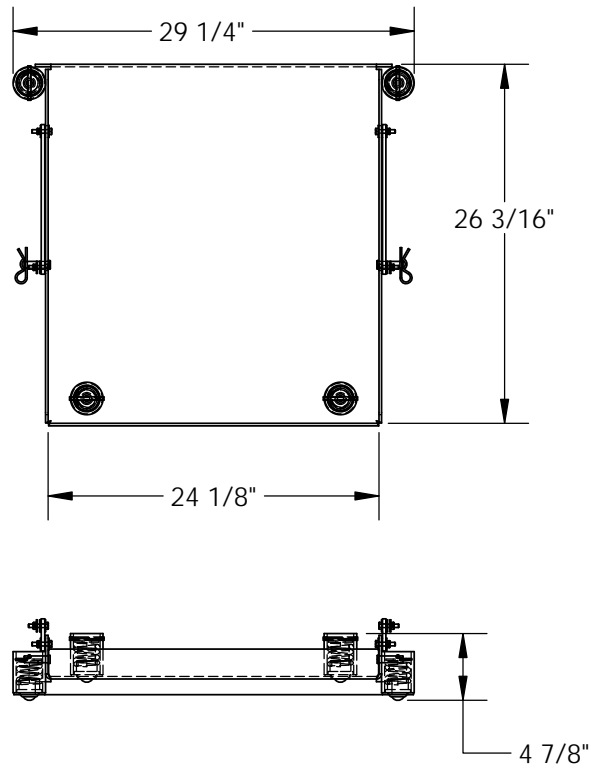

DIMENSION TOLERANCE $\pm 1/4$ "

STANDARD FEATURES

- MODEL NUMBER IS MTC-RB
- OVERALL WIDTH IS 29 1/4"
- USABLE WIDTH IS 24 1/8"
- OVERALL LENGTH IS 26 3/8"
- USABLE LENGTH IS 26 3/16"
- OVERALL HEIGHT IS 4 7/8"
- ROLL OUT LOAD CAPACITY IS 800 LBS
- FITS DRUMS: 55 & 30 GALLON

SPECIAL FEATURES

NONE

APPROVAL	I, THE UNDERSIGNED, AGREE THAT THE PRODUCT AS REPRESENTED SATISFIES DESIGN AND DIMENSION REQUIREMENTS. I ALSO ACKNOWLEDGE MY DUTY TO CONFIRM PRODUCT AND INSTALLATION COMPLIANCE WITH ALL APPLICABLE FEDERAL, STATE AND LOCAL REGULATIONS AND STANDARDS.	
	ANY MODIFIED UNITS ARE NON-RETURNABLE	
	[] As drawn [] As marked	
Signed: _____		Date: _____
Printed Name: _____		
<i>LEAD TIME WILL START UPON RECEIPT OF SIGNED APPROVAL DRAWING</i>		

FOR INTERNAL USE ONLY PROJECT SIGN OFF	
SALES	
ENG.	
FAB.	
POWER	

DISTRIBUTOR'S NAME:		P.O.#
VESTIL MANUFACTURING		X
DRAWN BY: CA		W.O.#
DATE: 2/13/14		X
REFERENCE: X	SCALE: 1:14	SALES: X
QUOTED LEAD TIME: X	QUOTE #	FILE NAME:
	X	22-007-009