

# SINGLE RAIL CHOCK/SINGLE RAIL CHOCK COMBO - SRC/SRC

APPROX WEIGHT: 15.69 lbs.  
DOES NOT INCLUDE WEIGHT OF POWER OR PACKAGING!!!

\*\*\* ANY ADDITIONS, DELETIONS, OR OMISSIONS MUST BE CORRECTED ON THIS DRAWING AS THIS DRAWING WILL BE CONSIDERED ALL INCLUSIVE \*\*\*  
ALL GRAPHICS PROVIDED ARE FOR REFERENCE ONLY. IF CERTAIN DIMENSIONS ARE CRITICAL PLEASE VERIFY THOSE DIMENSIONS WITH YOUR SALESPERSON

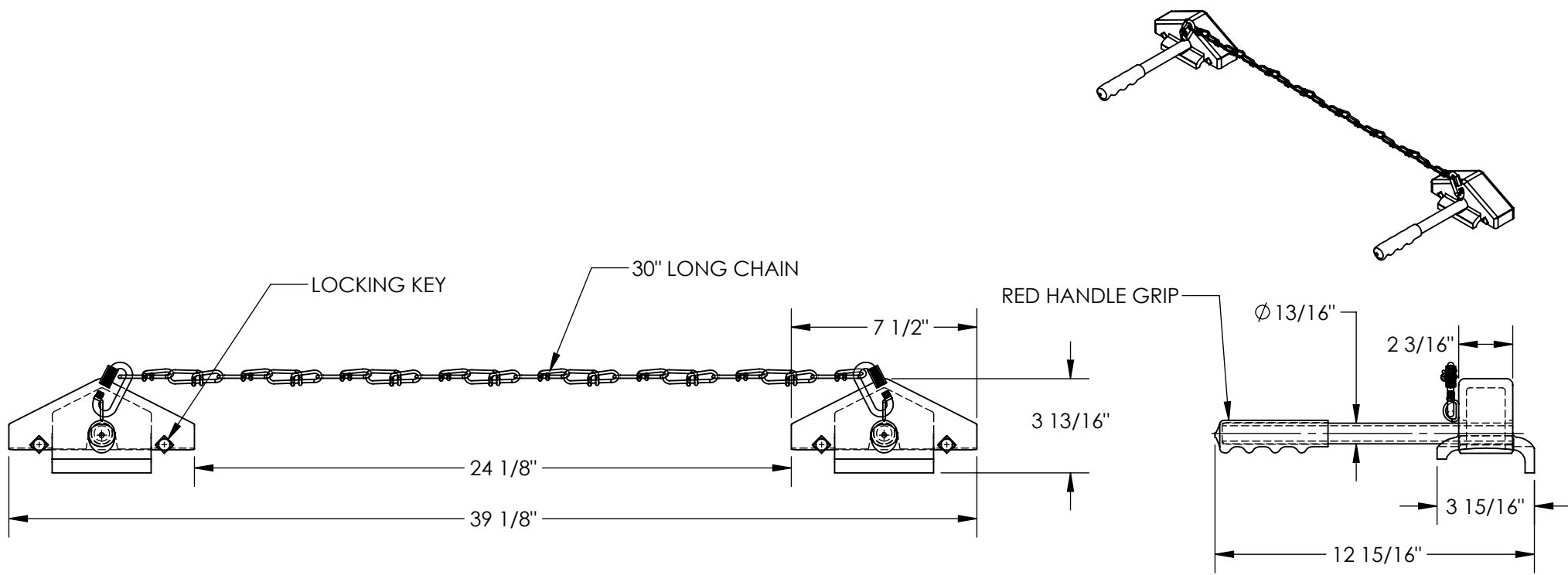

DIMENSION TOLERANCE ± 1/4"

## STANDARD FEATURES

- MODEL NUMBER IS SRC/SRC
- OVERALL WIDTH IS 12 15/16"
- CHOCK WIDTH IS 3 15/16"
- OVERALL LENGTH IS 39 1/8"
- CHOCK LENGTH IS 7 1/2"
- OVERALL HEIGHT IS 3 13/16"
- INCLUDES RED HANDLE GRIP
- TOUGH BAKED IN POWDER COATED YELLOW FINISH

## SPECIAL FEATURES

NONE

APPROVAL

I, THE UNDERSIGNED, AGREE THAT THE PRODUCT AS REPRESENTED SATISFIES DESIGN AND DIMENSION REQUIREMENTS. I ALSO ACKNOWLEDGE MY DUTY TO CONFIRM PRODUCT AND INSTALLATION COMPLIANCE WITH ALL APPLICABLE FEDERAL, STATE AND LOCAL REGULATIONS AND STANDARDS.  
**UNITS REQUIRING APPROVAL DRAWINGS OR MODIFIED ARE NON-RETURNABLE**  
[ ] As drawn [ ] As marked

Signed: \_\_\_\_\_ Date: \_\_\_\_\_

Printed Name: \_\_\_\_\_

LEAD TIME WILL START UPON RECEIPT OF SIGNED APPROVAL DRAWING

DISTRIBUTOR'S NAME:		P.O.#
VESTIL MANUFACTURING		X
DRAWN BY: RPS		W.O.#
DATE: 9/24/2012		X
REFERENCE: X	SCALE: 1:6	SALES: X
QUOTED LEAD TIME: X	QUOTE #	FILE NAME:
	X	29-007-214