

PNEUMATIC SCISSOR LIFT TABLE, AT-10

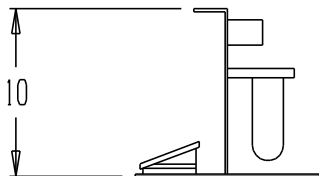
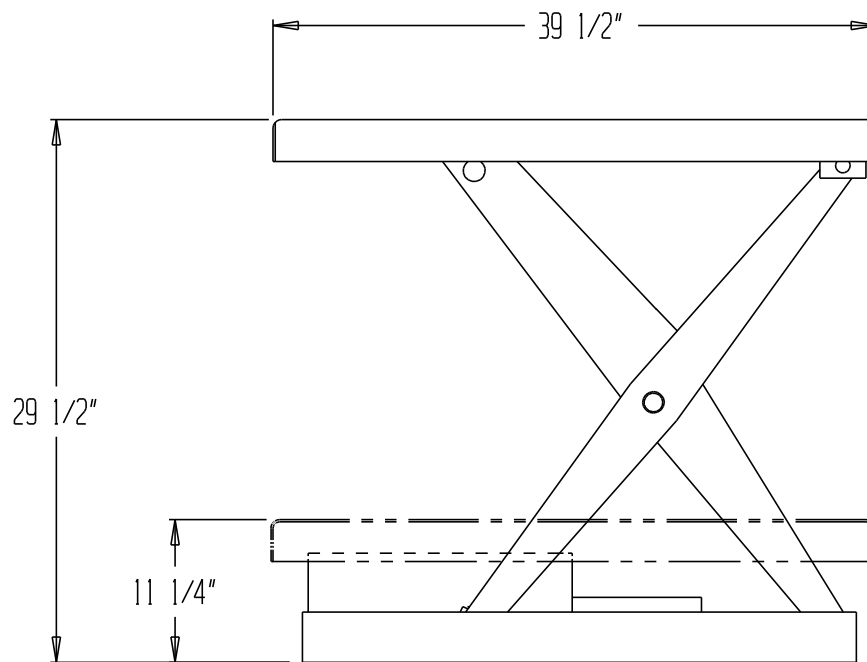
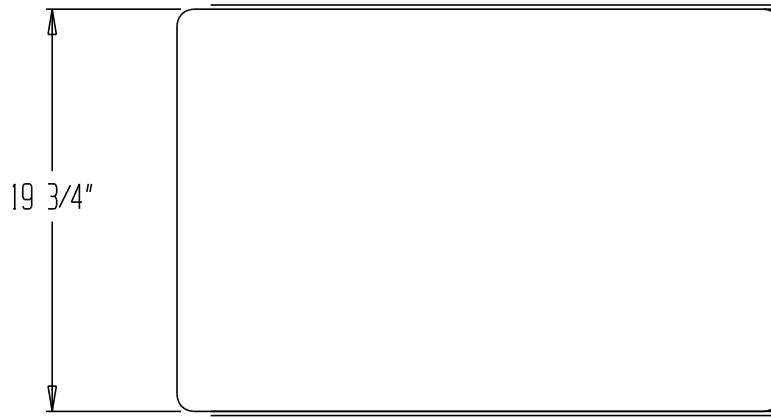
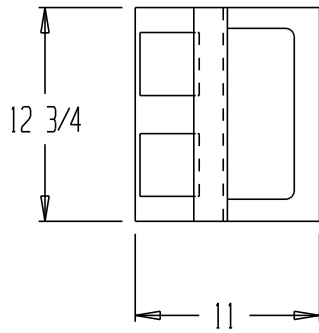

FOOT CONTROL
(W/ FILTER REGULATOR)

STANDARD FEATURES

- MODEL NUMBER: AT-10
- CAPACITY: 200 LBS.
- PLATFORM WIDTH: 19 1/2"
- PLATFORM LENGTH: 39 1/2"
- FRAME WIDTH: 19 1/4"
- FRAME LENGTH: 39 1/2"
- RAISED HEIGHT: 29 1/2"
- LOWERED HEIGHT: 11 1/4"
- COLOR: BLUE
- AIR POWERED
- OPERATION: FOOT CONTROL W/ 20" HOSE

**SPECIAL UNITS ARE NON-RETURNABLE
*AVAILABLE AT ADDITIONAL COSTS

PRODUCTION WILL START UPON
RECEIPT OF SIGNED APPROVAL
DRAWING

**A
P
P
R
O
V
A
L**

I, THE UNDERSIGNED, AGREE THAT THE PRODUCT AS REPRESENTED SATISFIES DESIGN & DIMENSION REQUIREMENTS. I ALSO ACKNOWLEDGE MY DUTY TO CONFIRM PRODUCT & INSTALLATION COMPLIANCE WITH ALL APPLICABLE FEDERAL, STATE AND LOCAL REGULATIONS & STANDARDS.

ALL SPECIAL UNITS ARE NON-RETURNABLE
[] As drawn [] As marked

Signed: _____ Date: _____

LEAD TIME WILL START UPON RECEIPT OF SIGNED APPROVAL DRAWING

SPECIAL FEATURES

NONE

DISTRIBUTOR'S NAME: VESTIL MFG		P.O.#: _
DRAWN BY: _____		W.O.#: _
DATE: 3/25/2014	SALES: _	DRWG./FILE NAME:
REFERENCE: _	SCALE: _	AT-10
QUOTED LEADTIME: _	QUOTE #: _	