

# ROLL PALLET TRUCK - PM4-4048-RL

APPROX WEIGHT: 749.00 lbs.  
 DOES NOT INCLUDE WEIGHT OF POWER OR PACKAGING!!!

\*\*\* ANY ADDITIONS, DELETIONS, OR OMISSIONS MUST BE CORRECTED ON THIS DRAWING AS THIS DRAWING WILL BE CONSIDERED ALL INCLUSIVE \*\*\*

ALL GRAPHICS PROVIDED ARE FOR REFERENCE ONLY. IF CERTAIN DIMENSIONS ARE CRITICAL PLEASE VERIFY THOSE DIMENSIONS WITH YOUR SALESPERSON

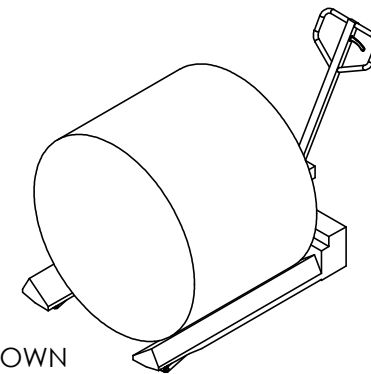
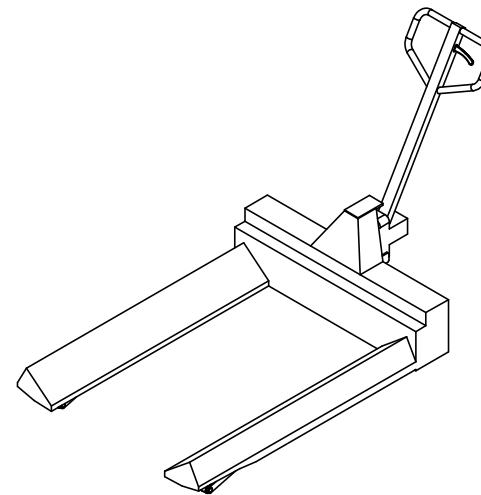
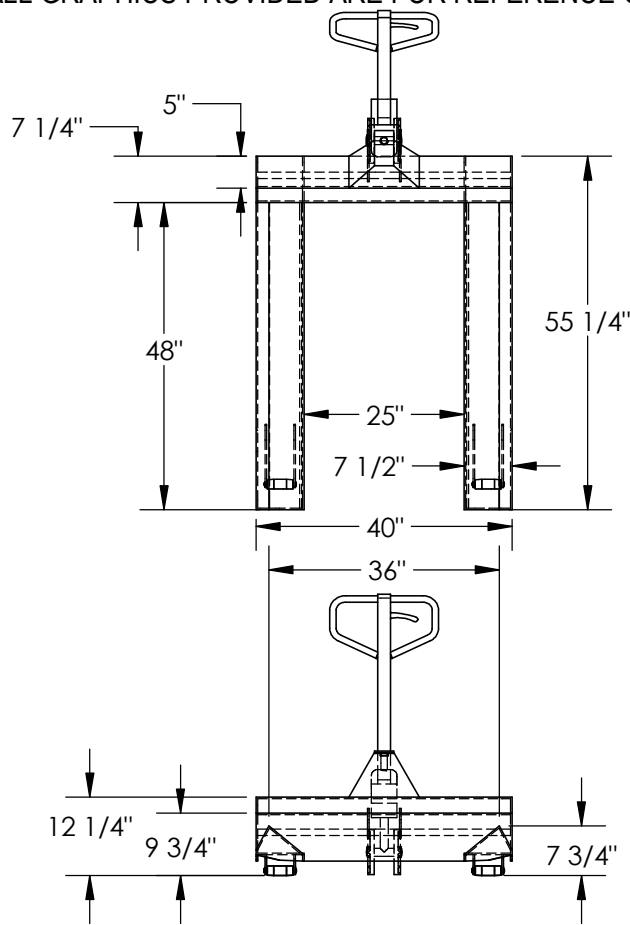

ROLL SHOWN FOR REFERENCE ONLY

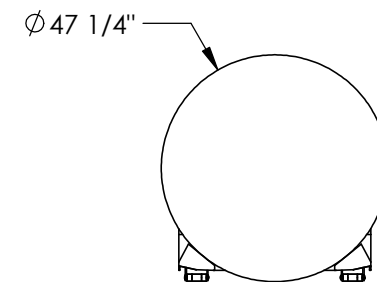
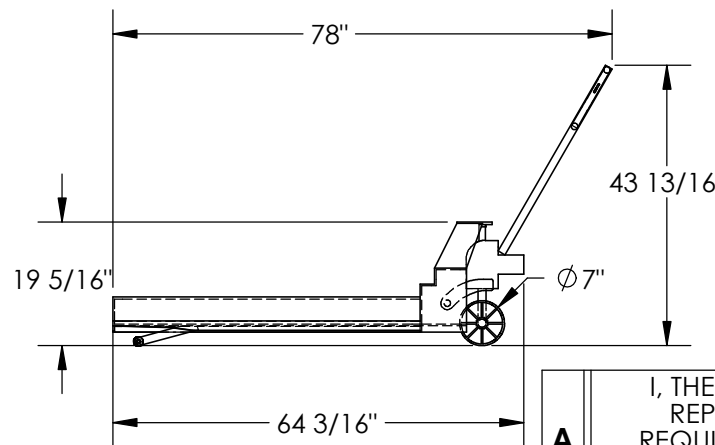

DIMENSION TOLERANCE  $\pm 1/2$ "

## STANDARD FEATURES

- MODEL NUMBER IS PM4-4048-RL
- OVERALL WIDTH IS 40"
- USABLE WIDTH IS 25"
- OVERALL LENGTH WITHOUT HANDLE IS 64 3/16"
- USABLE LENGTH IS 48"
- OVERALL HEIGHT WITHOUT HANDLE IS 19 5/16"
- MAX CAPACITY IS 4000 LBS. UNIFORM

- OVERALL MEASUREMENTS WITH HANDLE WILL VARY DEPENDING ON RESTING POSITION
- LENGTH WITH HANDLE IS 78"
- HEIGHT WITH HANDLE IS 43 13/16"

## SPECIAL FEATURES

NONE

APPROVAL

I, THE UNDERSIGNED, AGREE THAT THE PRODUCT AS REPRESENTED SATISFIES DESIGN AND DIMENSION REQUIREMENTS. I ALSO ACKNOWLEDGE MY DUTY TO CONFIRM PRODUCT AND INSTALLATION COMPLIANCE WITH ALL APPLICABLE FEDERAL, STATE AND LOCAL REGULATIONS AND STANDARDS.  
**ALL SPECIAL UNITS ARE NON-RETURNABLE**  
 As drawn       As marked

Signed: \_\_\_\_\_ Date: \_\_\_\_\_

LEAD TIME WILL START UPON RECEIPT OF SIGNED APPROVAL DRAWING

FOR INTERNAL USE ONLY PROJECT SIGN OFF	
SALES	
ENG.	
FAB.	
POWER	

DISTRIBUTOR'S NAME:		P.O.#
VESTIL MANUFACTURING		X
DRAWN BY:	DATE:	W.O.#
X	XX/XX/XX	X
REFERENCE:	SCALE:	SALES:
X	1:30	X
QUOTED LEAD TIME:	QUOTE #	FILE NAME:
X	X	15-007-142