

# PORTABLE CYLINDER LIFTER - CYL-LT-1-HR

APPROX WEIGHT: 96.83 lbs.  
DOES NOT INCLUDE WEIGHT OF POWER OR PACKAGING!!!

\*\*\* ANY ADDITIONS, DELETIONS, OR OMISSIONS MUST BE CORRECTED ON THIS DRAWING AS THIS DRAWING WILL BE CONSIDERED ALL INCLUSIVE \*\*\*

ALL GRAPHICS PROVIDED ARE FOR REFERENCE ONLY. IF CERTAIN DIMENSIONS ARE CRITICAL PLEASE VERIFY THOSE DIMENSIONS WITH YOUR SALESPERSON

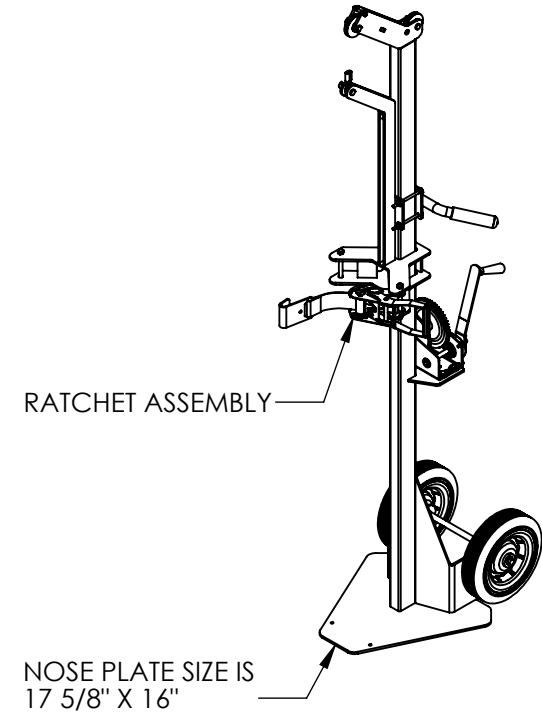
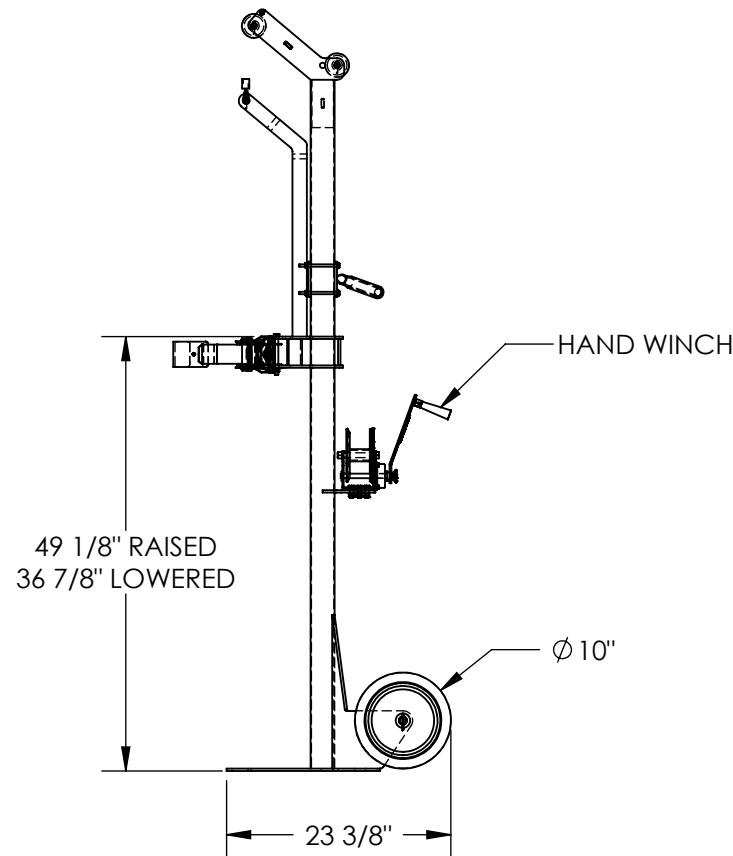
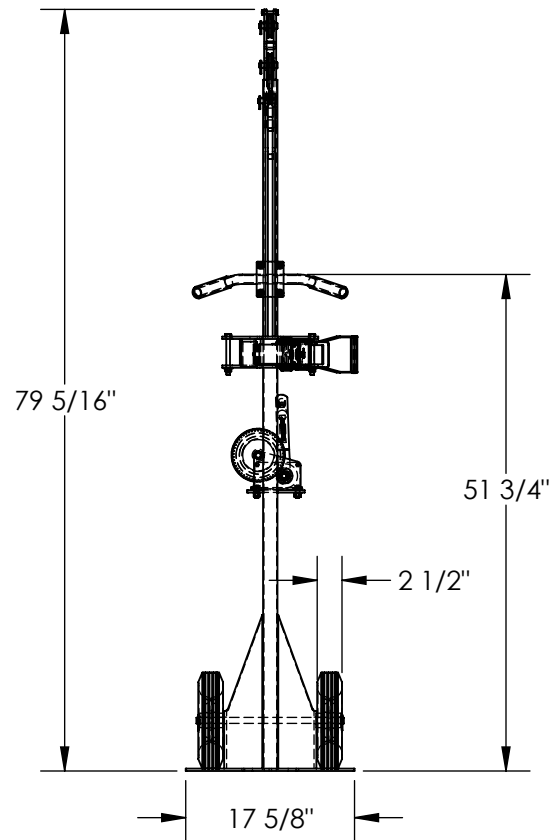

DIMENSION TOLERANCE ± 1/4"

## STANDARD FEATURES

- MODEL NUMBER IS CYL-LT-1-HR
- MAXIMUM CAPACITY IS 300 LBS.
- MAXIMUM CYLINDER DIAMETER IS Ø11 1/2"
- OVERALL WIDTH IS 17 5/8"
- OVERALL DEPTH IS 23 3/8"
- OVERALL HEIGHT IS 79 5/16"
- HARD RUBBER TIRE SIZE IS Ø10" X 2 1/2"
- ADJUSTABLE STRAP RAISED HEIGHT IS 49 1/8"
- ADJUSTABLE STRAP LOWERED HEIGHT 36 7/8"
- HAND WINCH OPERATION
- TOUGH BAKED IN POWDER COATED YELLOW FINISH

## SPECIAL FEATURES

NONE

APPROVAL	I, THE UNDERSIGNED, AGREE THAT THE PRODUCT AS REPRESENTED SATISFIES DESIGN AND DIMENSION REQUIREMENTS. I ALSO ACKNOWLEDGE MY DUTY TO CONFIRM PRODUCT AND INSTALLATION COMPLIANCE WITH ALL APPLICABLE FEDERAL, STATE AND LOCAL REGULATIONS AND STANDARDS.	
	<b>ANY MODIFIED UNITS ARE NON-RETURNABLE</b>	
	[ ] As drawn      [ ] As marked	
	Signed: _____ Date: _____	
Printed Name: _____		
<i>LEAD TIME WILL START UPON RECEIPT OF SIGNED APPROVAL DRAWING</i>		

FOR INTERNAL USE ONLY PROJECT SIGN OFF	
SALES	
ENG.	
FAB.	
POWER	

DISTRIBUTOR'S NAME:		P.O.#
VESTIL MANUFACTURING		X
DRAWN BY:	DATE:	W.O.#
J.RIDLEY	05/21/09	X
REFERENCE:	SCALE:	SALES:
X	1:20	X
QUOTED LEAD TIME:	QUOTE #	FILE NAME:
X	X	16-007-194