



Vestil Manufacturing Co.

2999 North Wayne Street, P.O. Box 507, Angola, IN 46703

Telephone: (260) 665-7586 -or- Toll Free (800) 348-0868

Fax: (260) 665-1339

www.vestil.com info@vestil.com

CYL-E and CYL-E-FF Welding Gas Cylinder Dollies

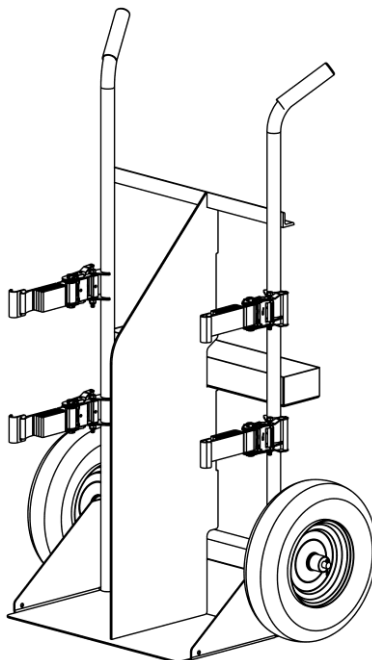

Receiving Instructions

After delivery, remove the packaging from the product. Inspect the product closely to determine whether it sustained damage during transport. If damage is discovered, record a complete description of it on the bill of lading. If the product is undamaged, discard the packaging.

NOTE: The end-user is solely responsible for confirming that product design, use, and maintenance comply with laws, regulations, codes, and mandatory standards applied where the product is used.

Technical Service & Replacement Parts

For answers to questions not addressed in these instructions and to order replacement parts, labels, and accessories, call our Technical Service and Parts Department at (260) 665-7586. The department can also be contacted online at <https://www.vestil.com/page-parts-request.php>.

Electronic copies of Instruction Manuals

Additional copies of this instruction manual may be downloaded from <https://www.vestil.com/page-manuals.php>.

Table of Contents		Page
Specifications		2
Signal Words		3
Safety Instructions		3
CYL-E Exploded View & Bill of Materials		4
CYL-E-FF Exploded View & Bill of Materials		5
Using the Cylinder Cart		6
Record of Satisfactory Condition		7
Inspecting and Maintaining the Cylinder Cart		7
Labeling Diagram		8
Limited Warranty		9

SPECIFICATIONS

Documents that provide specifications for CYL-E series cylinder carts are available online to anyone who visits Vestil's website. Specifications include dimensions, net weight, and capacity information. Navigate to <https://www.vestil.com/product.php?FID=886>. Scroll to the *Product Specifications Table* portion of the page. Find the entry for the cylinder cart you purchased and click the button in the "PDF" column that looks like a pencil inside a blue-bordered box. A PDF file will open. This file is the specifications document. Print a copy of the document and keep it with your copy of this manual. The following is an exemplar specifications document for model CYL-E.

ECONOMY CYLINDER CART - CYL-E

APPROX WEIGHT: 104.16 lbs.
DOES NOT INCLUDE WEIGHT OF POWER OR PACKAGING!!!

ANY ADDITIONS, DELETIONS, OR OMISSIONS MUST BE CORRECTED ON THIS DRAWING AS THIS DRAWING WILL BE CONSIDERED ALL INCLUSIVE

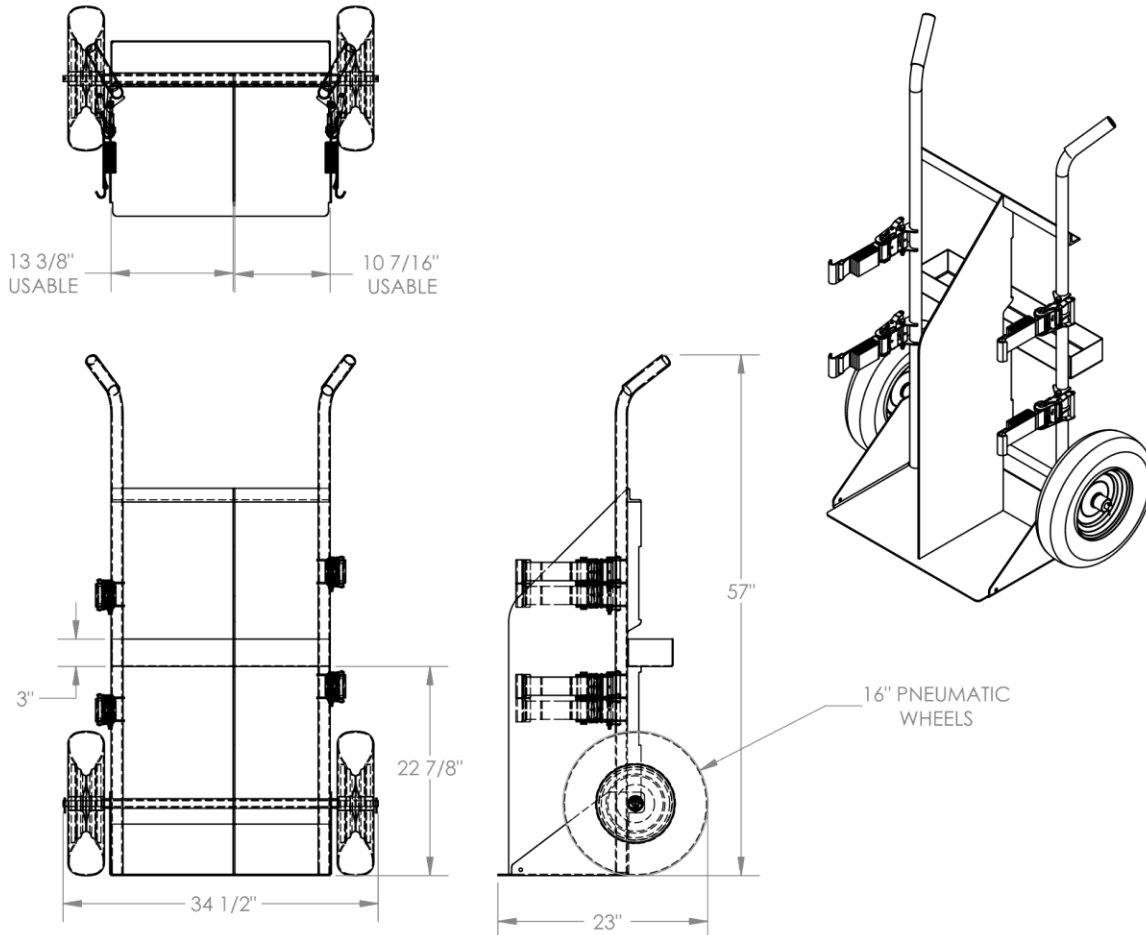

ALL GRAPHICS PROVIDED ARE FOR REFERENCE ONLY. IF CERTAIN DIMENSIONS ARE CRITICAL PLEASE VERIFY THOSE DIMENSIONS WITH YOUR SALESPERSON

DIMENSION TOLERANCE $\pm 1/4$ "

STANDARD FEATURES

- MODEL NUMBER IS CYL-E
- CAPACITY IS 500 LBS
- OVERALL WIDTH IS 34 1/2"
- LEFT SIDE USABLE WIDTH IS 13 3/8"
- RIGHT SIDE USABLE WIDTH IS 10 7/16"
- OVERALL DEPTH IS 23"
- OVERALL HEIGHT IS 57"
- STRAPS TO SECURE TANKS
- 16" PNEUMATIC WHEELS
- TOUGH BAKED IN POWDER COATED YELLOW FINISH

SPECIAL FEATURES

NONE

APPROVAL	I, THE UNDERSIGNED, AGREE THAT THE PRODUCT AS REPRESENTED SATISFIES DESIGN AND DIMENSION REQUIREMENTS. I ALSO ACKNOWLEDGE MY DUTY TO CONFIRM PRODUCT AND INSTALLATION COMPLIANCE WITH ALL APPLICABLE FEDERAL, STATE AND LOCAL REGULATIONS AND STANDARDS.		
	UNITS REQUIRING APPROVAL DRAWINGS OR MODIFIED ARE NON-RETURNABLE		
	[] As drawn [] As marked		
	Signed: _____		Date: _____
Printed Name: _____			
LEAD TIME WILL START UPON RECEIPT OF SIGNED APPROVAL DRAWING			
DISTRIBUTOR'S NAME: VESTIL MANUFACTURING		P.O.# X	
DRAWN BY: TJM		W.O.# X	
DATE: 03/05/10	SALES: X		
REFERENCE: X	SCALE: 1:16	FILE NAME:	
QUOTED LEAD TIME: X	QUOTE # X	16-007-237	

SIGNAL WORDS

This manual uses SIGNAL WORDS to indicate the likelihood of personal injuries, as well as the probable seriousness of those injuries, if the product is misused in the ways described. Other signal words call attention to uses of the product likely cause property damage. The following are signal words used in this manual and their definitions.

DANGER

Identifies a hazardous situation which, if not avoided, **WILL** result in DEATH or SERIOUS INJURY. Use of this signal word is limited to the most extreme situations.

WARNING

Identifies a hazardous situation which, if not avoided, **COULD** result in DEATH or SERIOUS INJURY.

CAUTION

Indicates a hazardous situation which, if not avoided, **COULD** result in MINOR or MODERATE injury.

NOTICE

Identifies practices likely to result in product/property damage, such as operation that might damage the product.

SAFETY INSTRUCTIONS

Vestil strives to identify foreseeable hazards associated with the use of its products. However, no manual can address every conceivable risk. Minimize risk by keeping the cart in optimal condition, by inspecting and maintaining the product as instructed in the *INSPECTIONS & MAINTNENANCE* section of this manual, by applying the lessons of these *SAFETY INSTRUCTIONS*, and by exercising sound judgment whenever using this device.

WARNING

Risks of serious personal injuries or death.

- **Read this manual in its entirety before assembling, installing, using, inspecting or servicing the product.** A copy of this manual should always be available to all persons who assemble, install, use, inspect, or maintain this device.
- DO NOT exceed the maximum rated load.
- Inspect the cart as instructed in [INSPECTING & MAINTAINING THE CYLINDER CART](#) on p. 7. Remove the cart from service if the inspection reveals changes from [satisfactory condition](#), including: 1) cracked welds; 2) corrosion, extreme wear, or other condition that affects the ability of the product to support weight; 3) significantly worn or damaged wheels; 4) missing ratchet straps. DO NOT use the product until it is restored to normal condition. ONLY use manufacturer-approved replacement parts.
- DO NOT use the cart to transport any cylinder that does not seat securely in the brackets.
- DO NOT transport a cylinder without firmly applying the ratchet straps.
- ALWAYS apply safe lifting practices whenever the cart is connected to a lifting device (e.g. overhead hoist).
- When transporting a cylinder up-or-downhill, always remain uphill to the cylinder.
- DO NOT remove or obscure any label. All product labels must be readable and undamaged.
- DO NOT modify the cart in any way. Unauthorized modifications automatically void the limited warranty (see p. 7) and might make the cart unsafe to use.

NOTICE

Proper use, maintenance, and storage are essential for this product to function properly.

- Keep the product clean & dry.
- Only store the cart indoors.

CYL-E EXPLODED VIEW AND BILL OF MATERIALS

16-006-237

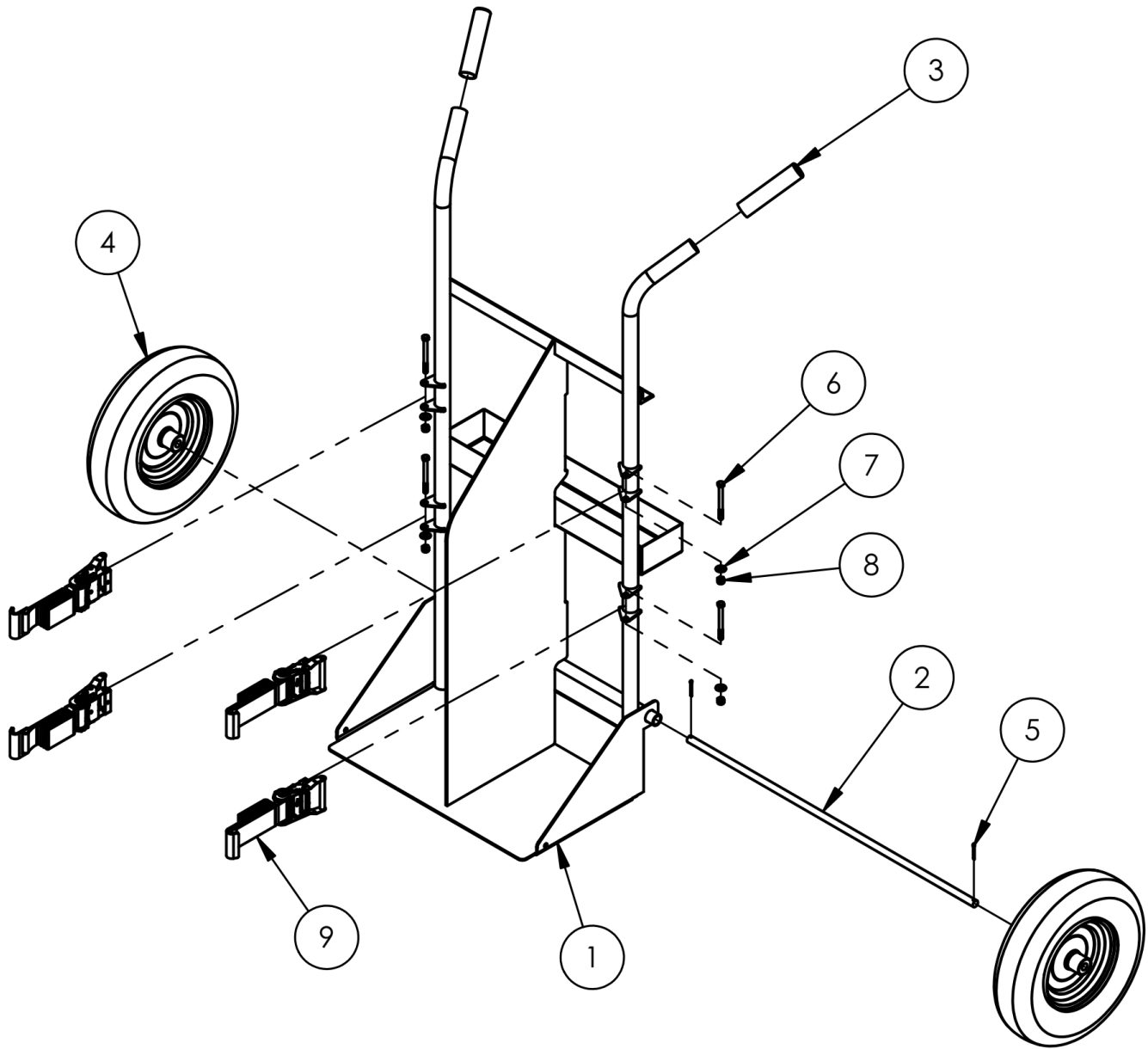

Item	Part no.	Description	Quantity
1	16-514-161	WELDMENT, FRAME SUB-ASSEMBLY	1
2	16-112-044	AXLE, PIN	1
3	07-025-005	HANDLE, BLACK RUBBER, 6"	2
4	16-132-126	PNEUMATIC TIRE, 4" X 16"	2
5	65078	EXTENDED PRONG COTTER PIN, ZINC FINISH, 1/8" x 1 1/2"	2
6	11067	HHCS #2 Z PLATED, GRADE A, Ø 5/16 - 18 x 3.5 LG	4
7	33006	FLAT WASHER, ZINC PLATED, USS, Ø5/16"	4
8	37021	NYLON INSERT LOCK NUT, GRADE 2, ZINC FINISH, 5/16"-18	4
9	16-145-018	2" x 36" STRAP WITH RATCHET	4

CYL-E-FF EXPLODED PARTS DIAGRAM AND BILL OF MATERIALS

16-006-241

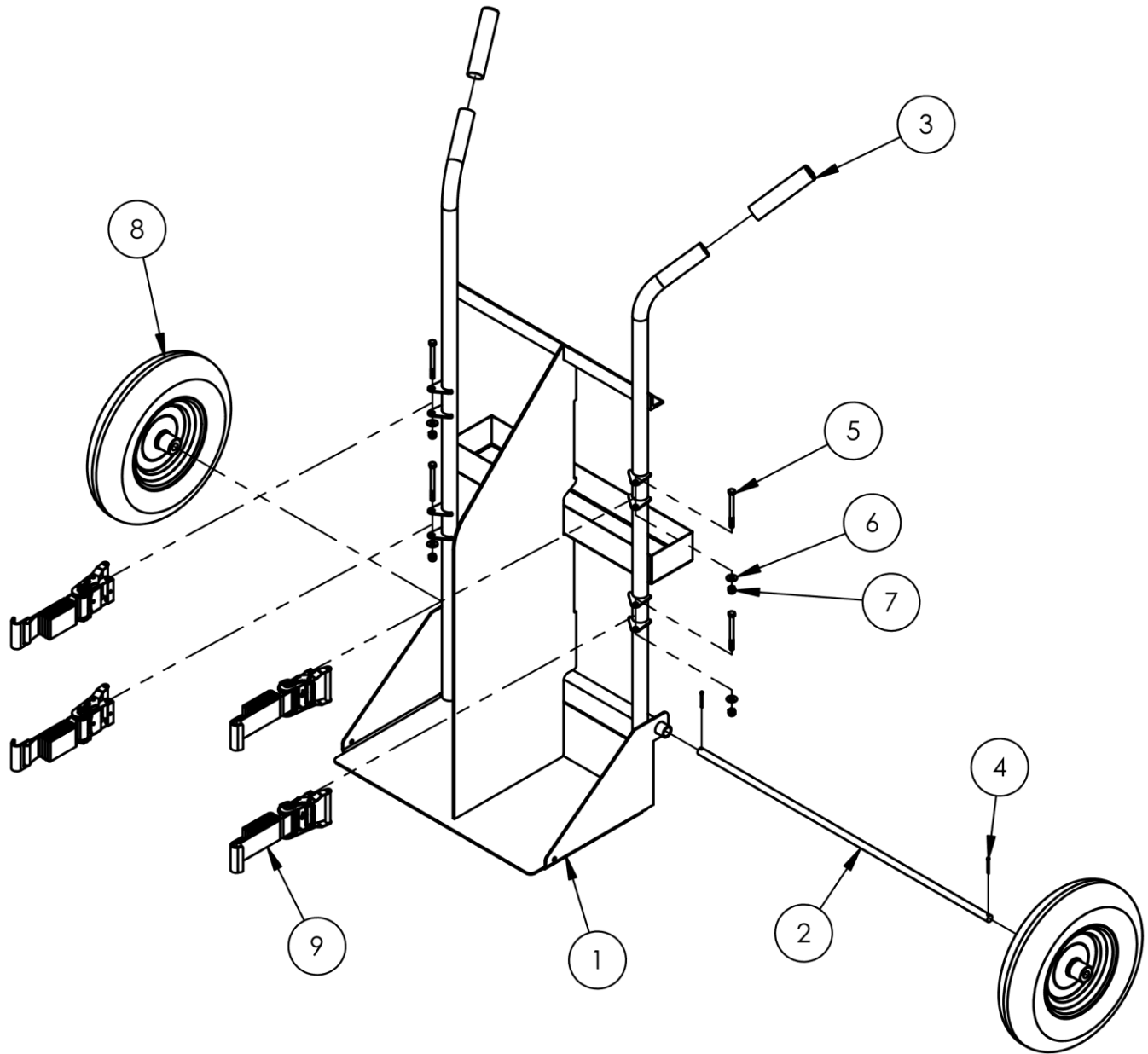

ITEM	PART NO.	DESCRIPTION	QTY.
1	16-514-161	WELDMENT, FRAME SUB-ASSEMBLY	1
2	16-112-044	AXLE, PIN	1
3	07-025-005	HANDLE, BLACK RUBBER, 6"	2
4	65078	EXTENDED PRONG COTTER PIN, ZINC FINISH, 1/8" x 1 1/2"	2
5	11067	HHCS #2 Z PLATED, GRADE A, Ø 5/16 - 18 x 3.5 LG	4
6	33006	FLAT WASHER,ZINC PLATED,USS, Ø5/16"	4
7	37021	NYLON INSERT LOCK NUT, GRADE 2, ZINC FINISH, 5/16"-18	4
8	16-132-246	Ø16" X 4" FOAM FILLED WHEEL	2
9	16-145-018	2" x 36" STRAP WITH RATCHET	4

USING THE CYLINDER CART

1. Place a cylinder on the cylinder support (see below). Position the cylinder so that it rests firmly against the cross bar.
2. Release the ratchet to extend the strap. To release the ratchet, pull the release lever toward the handle and pivot the handle as far from the base as it will travel (approximately 180 degrees). By pulling on the strap now, it will unwind from the spindle. Ratchet parts are identified in Fig. B below.
3. Wrap the ratchet straps around the cylinder and connect the J-hooks to the J-hook slots of the divider. See Fig. B.
4. Pivot the handle back towards the base and let go of the release lever.
5. Tighten the strap against the cylinder by moving the handle back-and-forth.
6. To remove a cylinder from the cart, release strap tension by following the procedure described in step 2 (above).

FIG. A: Cylinder cart

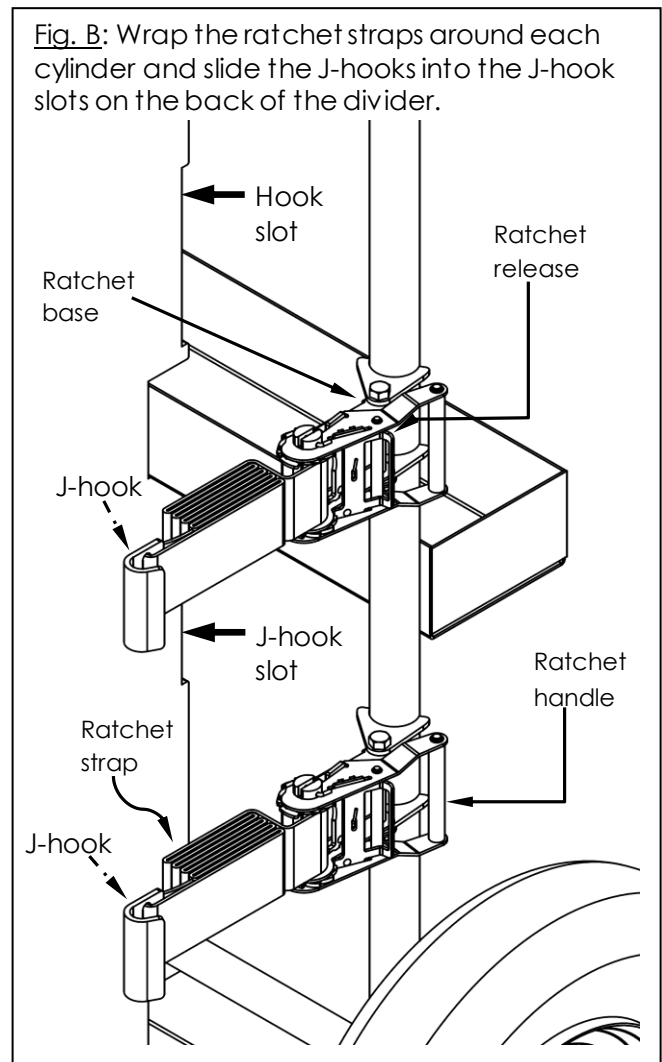
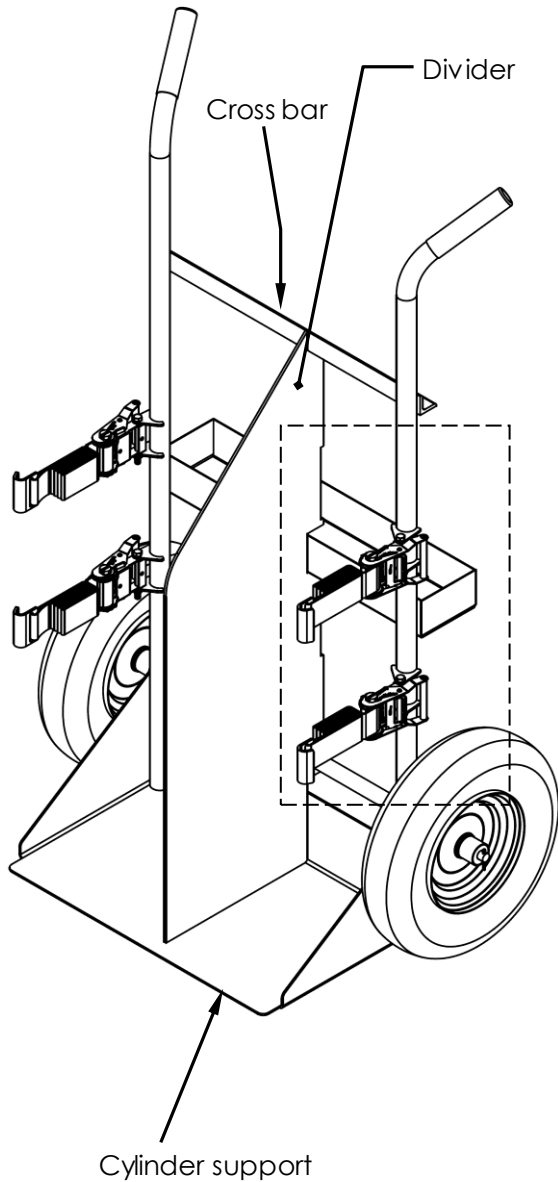

Fig. B: Wrap the ratchet straps around each cylinder and slide the J-hooks into the J-hook slots on the back of the divider.

RECORD OF SATISFACTORY CONDITION (THE “RECORD”)

Before using this cart for the first time, create a record of its appearance and features. Photograph the unit from multiple angles so that all features are clearly imaged. Take close range photographs of the ratchets and straps, labels, handle grips, wheels, and welds. Collect all writings and photographs in a file. This file is a record of the unit in satisfactory condition. **Compare the results of all inspections to this Record to determine whether the unit is still in satisfactory condition.** Restore the cart to satisfactory condition BEFORE using it again. Cosmetic changes, like damaged surface coating (paint or powdercoat) are not changes from satisfactory condition. However, touchup paint should be applied as soon as damage occurs to prevent rusting. Left untreated, rusting could compromise the integrity of the metal.

INSPECTING & MAINTAINING THE CYLINDER CART

Inspections and repairs should only be performed by qualified persons. Compare the results of each inspection to the [RECORD OF SATISFACTORY CONDITION](#) (the “RECORD”). Do not use the cart unless all parts are in satisfactory condition. Replace parts that are not in satisfactory condition before using the cart again. **DON'T GUESS! If you have any questions about the condition of your cart, speak with [TECHNICAL SERVICE](#) personnel.** The phone number is provided on the cover page of this manual. **Never make temporary repairs of damaged or missing parts.** Only use manufacturer-approved replacement parts.

Make a dated record of each inspection that includes observations and descriptions of repairs and replacement parts installed.

Inspect the cylinder cart at least once per month.

1. Examine the frame for cracked welds, metal fatigue, rust, and corrosion that affects the structural integrity of the cart. The structure should be clean, square and rigid, and free of rust and corrosion. Remove dirt and debris.
2. Check the ratchets and straps. Confirm normal operation and condition. Replace damaged straps and ratchets.
3. Labels: Confirm that all labels shown in the *LABELING DIAGRAM* are present, undamaged and easily readable. Order replacements for any labels that are missing or not easily readable.

LABELING DIAGRAM

Label content and location are subject to change, and therefore, your product might not be labeled exactly as shown in the diagram below. If the labels applied to your unit differ from those shown in the diagram, contact [TECHNICAL SERVICE](#) and report the inconsistency. Thoroughly photograph the unit when you first receive it as discussed in the [Record of Satisfactory Condition](#) section on p. 7. Make sure that your Record includes at least 1 photograph of each label. Replace all labels that are, or later become, damaged, missing, or not easily readable (e.g. faded). To order replacement labels, contact the *Technical Service & [Parts Department](#)* online at <https://www.vestil.com/page-parts-request.php> or by calling (260) 665-7586 and asking the operator to connect you to the [Parts Department](#).

A & B (back side of cross bar facing user))

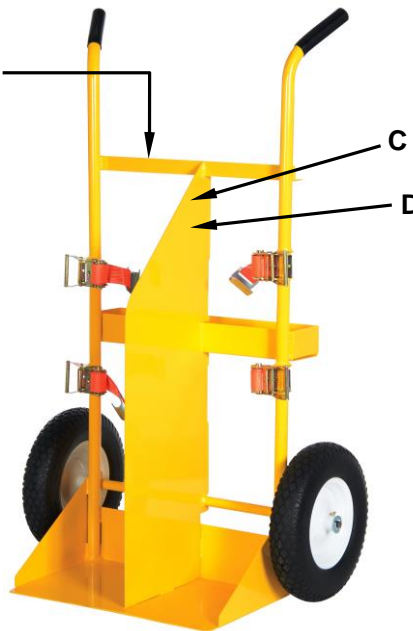

A: Label 658

WARNING	ADVERTENCIA	AVERTISSEMENT
Do not operate or move with unstable loads DO NOT LOAD beyond rated capacity DISTRIBUTE LOAD EVENLY DO NOT sit or ride	No use a mueva con cargas inestables No cargue mas de la capacidad tasada DISTRIBUYA LA CARGA A NIVEL NO SE SIENTE o vaya en el carro	Ne pas utiliser avec une charge instable NE PAS CHARGER au-delà du débit nominale DISTRIBUER la charge régulièrement NE PAS VOUS ASSEoir OU VOUS PROMENER sur le chariot
		658 rev 0808

B: Label 1153

MODEL / MODÉLO / MODÈLE _____
WEIGHT / PESO / MASS _____
CAPACITY / CAPACIDAD / CAPACITÉ _____
SERIAL / SERIE / SÉRIE _____
UNITS: 2.2 lb. = 1kg 1" (or 1in.) = 2.54cm 1153

C: Label 821

	WARNING
	Risk of serious injury or death. Read and understand entire owner's manual BEFORE using.
821 rev 0108	

D: Label 286

WARNING	ADVERTENCIA
ONLY use to transport cylinders; DO NOT use as a storage device. Secure cylinder to dolly with all restraints For your safety, read all warnings on the cylinder	SOLO use para transportar cilindros NO USE como dispositivo de almacenaje Asegure el cilindro a la plataforma con todas las correas Para su seguridad, lea todas las advertencias en el cilindro
	286 Rev 0611

LIMITED WARRANTY

Vestil Manufacturing Company ("Vestil") warrants this product to be free of defects in material and workmanship during the warranty period. Our warranty obligation is to provide a replacement for a defective, original part covered by the warranty after we receive a proper request from the Warrantee (you) for warranty service.

Who may request service?

Only a warrantee may request service. You are a warrantee if you purchased the product from Vestil or from an authorized distributor AND Vestil has been fully paid.

Definition of "original part"?

An original part is a part used to make the product as shipped to the Warrantee.

What is a "proper request"?

A request for warranty service is proper if Vestil receives: 1) a photocopy of the Customer Invoice that displays the shipping date; AND 2) a written request for warranty service including your name and phone number. Send requests by one of the following methods:

US Mail
Vestil Manufacturing Company
2999 North Wayne Street, PO Box 507
Angola, IN 46703

Fax
(260) 665-1339
Phone
(260) 665-7586

Email
info@vestil.com
Enter "Warranty service request" in the subject field.

In the written request, list the parts believed to be defective and include the address where replacements should be delivered. After Vestil receives your request for warranty service, an authorized representative will contact you to determine whether your claim is covered by the warranty. Before providing warranty service, Vestil will require you to send the entire product, or just the defective part (or parts), to its facility in Angola, IN.

What is covered under the warranty?

The warranty covers defects in the following original, dynamic parts: motors, hydraulic pumps, motor controllers, and cylinders. It also covers defects in original parts that wear under normal usage conditions ("wearing parts"), such as bearings, hoses, wheels, seals, brushes, and batteries.

How long is the warranty period?

The warranty period for original dynamic components is 90 days. For wearing parts, the warranty period is 90 days. Both warranty periods begin on the date Vestil ships the product to the Warrantee. If the product was purchased from an authorized distributor, the periods begin when the distributor ships the product. Vestil may, at its sole discretion, extend a warranty period for products shipped from authorized distributors by up to 30 days to account for shipping time.

If a defective part is covered by the warranty, what will Vestil do to correct the problem?

Vestil will provide an appropriate replacement for any covered part. An authorized representative of Vestil will contact you to discuss your claim.

What is not covered by the warranty?

The Warrantee (you) is responsible for paying labor costs and freight costs to return the product to Vestil for warranty service.

Events that automatically void this Limited Warranty.

- Misuse;
- Negligent assembly, installation, operation or repair;
- Installation/use in corrosive environments;
- Inadequate or improper maintenance;
- Damage sustained during shipping;
- Collisions or other accidents that damage the product;
- Unauthorized modifications: Do not modify the product IN ANY WAY without first receiving written authorization from Vestil.

Do any other warranties apply to the product?

Vestil Manufacturing Co. makes no other express warranties. All implied warranties are disclaimed to the extent allowed by law. Any implied warranty not disclaimed is limited in scope to the terms of this Limited Warranty. Vestil makes no warranty or representation that this product complies with any state or local design, performance, or safety code or standard. Noncompliance with any such code or standard is not a defect in material or workmanship.