

TRASH CAN CART - TH-CART-95

APPROX WEIGHT: 248.13 lbs.
DOES NOT INCLUDE WEIGHT OF POWER OR PACKAGING!!!

*** ANY ADDITIONS, DELETIONS, OR OMISSIONS MUST BE CORRECTED ON THIS DRAWING AS THIS DRAWING WILL BE CONSIDERED ALL INCLUSIVE ***

ALL GRAPHICS PROVIDED ARE FOR REFERENCE ONLY. IF CERTAIN DIMENSIONS ARE CRITICAL PLEASE VERIFY THOSE DIMENSIONS WITH YOUR SALESPERSON

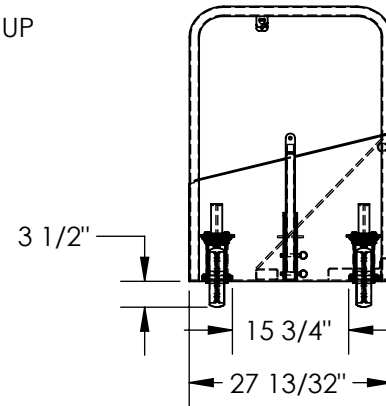
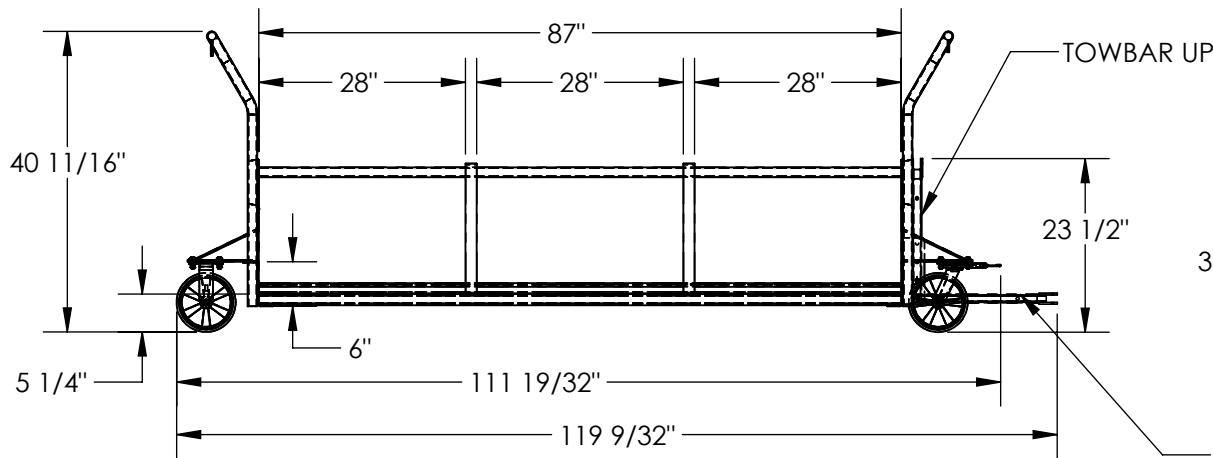
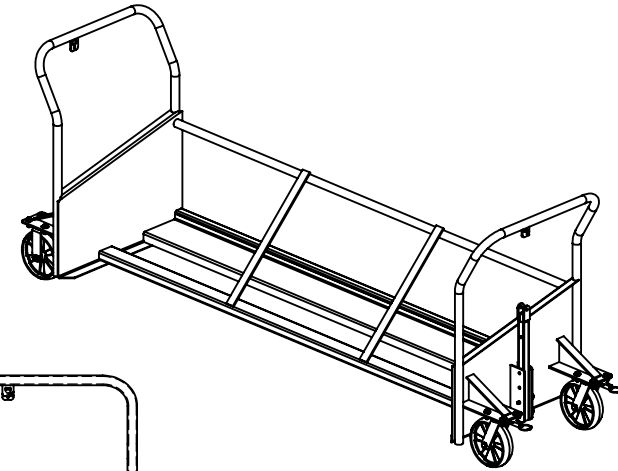
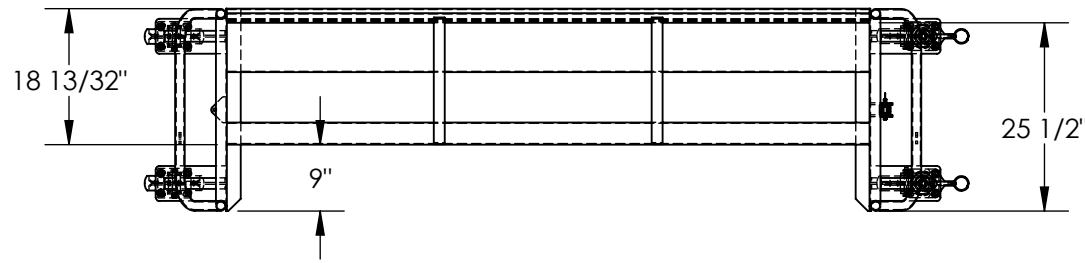

DIMENSION TOLERANCE $\pm 1/4$ "

STANDARD FEATURES

- MODEL NUMBER IS: TH-CART-95
- OVERALL WIDTH IS: 27 13/32"
- USABLE WIDTH IS: 18 13/32"
- OVERALL LENGTH IS: 119 9/32"
- USABLE LENGTH IS: 28"
- OVERALL HEIGHT IS: 40 11/16"
- MAX CAPACITY IS: UP TO (3) 95 GALLON TRASH CANS
- TOW BAR CAN BE ADJUSTED VERTICALLY IN 2 1/2" INCREMENTS
- TOW BAR HAS A FULLY EXTENDED LENGTH OF 30 7/8"
- TOW BAR HAS A FULLY RETRACTED LENGTH OF 19 5/8"
- RECEPTACLE RESTRAINT CHAIN NOT SHOWN: $\varnothing 3/16$ " x 112" LONG
- PUSH HANDLES ON EACH END
- (2) RIGID AND (2) SWIVEL CASTERS
- MULTIPLE UNITS MAY BE CONNECTED END-TO-END FOR TOWING
- WELDED STEEL CONSTRUCTION WITH POWDERCOAT BLACK FINISH

SPECIAL FEATURES

NONE

APPROVAL	I, THE UNDERSIGNED, AGREE THAT THE PRODUCT AS REPRESENTED SATISFIES DESIGN AND DIMENSION REQUIREMENTS. I ALSO ACKNOWLEDGE MY DUTY TO CONFIRM PRODUCT AND INSTALLATION COMPLIANCE WITH ALL APPLICABLE FEDERAL, STATE AND LOCAL REGULATIONS AND STANDARDS.	
	ANY MODIFIED UNITS ARE NON-RETURNABLE	
	[] As drawn [] As marked	
	Signed: _____	Date: _____
Printed Name: _____		
LEAD TIME WILL START UPON RECEIPT OF SIGNED APPROVAL DRAWING		

FOR INTERNAL USE ONLY PROJECT SIGN OFF	
SALES	
ENG.	
FAB.	
POWER	

DISTRIBUTOR'S NAME:		P.O.#
VESTIL MANUFACTURING		X
		W.O.#
DRAWN BY: A. HUGHES	DATE: 03/27/2012	X
REFERENCE: X	SCALE: 1:26	FILE NAME:
QUOTED LEAD TIME: X	QUOTE #	16-007-322
	X	