



Vestil Manufacturing Corp.
 2999 North Wayne Street, P.O. Box 507, Angola, IN 46703
 Telephone: (260) 665-7586 -or- Toll Free (800) 348-0868

RR-Series & EH-Series Dock Levelers Instruction Manual



RR Series (Mechanical)



EH Series (Electric-Hydraulic)

Receiving instructions:

After delivery, remove the packaging from the product. Inspect the product closely to determine whether it sustained damage during transport. If damage is discovered, record a complete description of it on the bill of lading. If the product is undamaged, discard the [packaging](#).

NOTE: The end-user is solely responsible for confirming that product design, use, and maintenance comply with laws, regulations, codes, and mandatory standards applied where the product is used.

Replacement Parts and Technical Assistance:

For answers to questions not addressed in these instructions and to order replacement parts, labels, and accessories, call our Technical Service and Parts Department at (260) 665-7586. The department can also be contacted online at http://www.vestilmfg.com/parts_info.htm.

TABLE OF CONTENTS

Signal Words.....	2
Hazards of Improper Use.....	2
EH-65, EH-66, EH-68 and EH-610 Exploded View & Bill of Materials.....	3
EH-75, EH-76, EH-78 and EH-710 Exploded View & Bill of Materials.....	4
Power Unit Exploded View and Bill of Materials [EH-65; EH-66; & EH-68].....	5
Power Unit Exploded View and Bill of Materials [EH-610; EH-75; EH-76; EH-78; & EH-710].....	6
Manifold Exploded View and Bill of Materials [EH-65; EH-66; & EH-68].....	7
Manifold Exploded View and Bill of Materials [EH-610; EH-75; EH-76; EH-78; & EH-710].....	7
Electrical Circuit Diagram, 115V AC, 1-Phase [EH Dock Levelers].....	8
Electrical Circuit Diagram, 208-230V AC, 1-Phase [EH Dock Levelers].....	9
Electrical Circuit Diagram, 3-Phase AC [EH Dock Levelers].....	10
Electrical System Operation [EH Dock Levelers].....	11
Hydraulic Circuit Sequence of Operation [EH Dock Levelers].....	11
Adjusting Hydraulic Settings [EH Dock Levelers].....	12
RR-65, RR-66, RR-68, and RR-610 Exploded View and Bill of Materials.....	13 - 14
RR-75, RR-76, RR-78, and RR-710 Exploded View and Bill of Materials.....	15 - 16
Installation.....	17
Operation: EH Series.....	17, 18, 19
Operation: RR Series.....	19
Troubleshooting: EH-Series.....	20
Inspections and Maintenance: EH-Series.....	21
Inspections and Maintenance: RR-Series.....	22
Adjusting Spring Tension: RR-Series.....	23
Labeling Diagrams: RR-Series and EH-Series.....	24
Limited Warranty.....	25

Signal Words:

This manual uses SIGNAL WORDS to indicate the likelihood that a particular action will cause personal injuries or property damage. Signal words also specify the level of seriousness of injury if the product is misused in the ways described. The following signal words are used in this manual.

⚠ WARNING Identifies a hazardous situation which, if not avoided, **COULD** result in **DEATH** or **SERIOUS INJURY**.

⚠ CAUTION Indicates a hazardous situation which, if not avoided, **COULD** result in **MINOR** or **MODERATE** injury.

NOTICE Identifies actions likely to result in product/property damage, such as operation that might damage the product.

Hazards of Improper Use:

Vestil strives to identify foreseeable hazards associated with the use of its products. However, material handling is dangerous and no manual can address every conceivable risk. The end-user ultimately is responsible for exercising sound judgment at all times.

⚠ WARNING If this product is used or maintained improperly serious personal injuries or death might result. **ALWAYS** use the product properly.

• ***Failure to read and understand the entire manual before assembling, using or servicing the product constitutes misuse.***

• Read the manual to refresh your understanding of proper use and maintenance procedures whenever necessary.

• **DO NOT** attempt to resolve any issue with the product unless you are certain that it will be safe to use afterwards.

• **DO NOT** modify the product in any way. Unauthorized modifications might make the lifter unsafe to use and automatically void the *Limited Warranty* (see p. 25).

• **DO NOT** exceed the capacity of your unit. Capacity information appears on the product in label 287. The *Labeling Diagrams* on p. 24 indicates where to find label 287 on your dock leveler.

• Inspect the product according to the instructions on p. 21 & 22. Replace each part that is not in normal condition. **DO NOT** use the product until it is fully restored to normal condition. **ONLY** use manufacturer-approved replacement parts.

• Cycle the deck all the way up and all the way down. Listen for unusual sounds as the deck rises and lowers. Watch the deck for unusual movement.

• **DO NOT** use the dock leveler unless all machine guards are in place.

• This product is **NOT** a personnel lift. **DO NOT** use it to lift or transport people.

• [Hydraulically actuated units] **NEVER** change the setting of the pressure relief valve.

• **DO NOT** use this device **UNLESS** all labels are in place, readable, and undamaged. See *Labeling Diagrams* on p.24.

NOTICE Proper use, maintenance, and storage are essential for this product to function properly.

○ Always use this product in accordance with the instructions in this manual and consistent with any training relevant to machines, devices, etc. used in conjunction with this product.

○ Keep the product clean & dry. Periodically lubricate moving parts.

○ **FOR HYDRAULIC UNITS:** Do not use brake fluid or jack oils in the hydraulic system. If oil is needed, use an anti-wear hydraulic oil with a viscosity grade of 150 SUS at 100°F, (ISO 32 cSt @ 40°C), or Dexron transmission fluid.

○ Contact the manufacturer for SDS information

EH-65, EH-66, EH-68 and EH-610 Exploded View and Bill of Materials

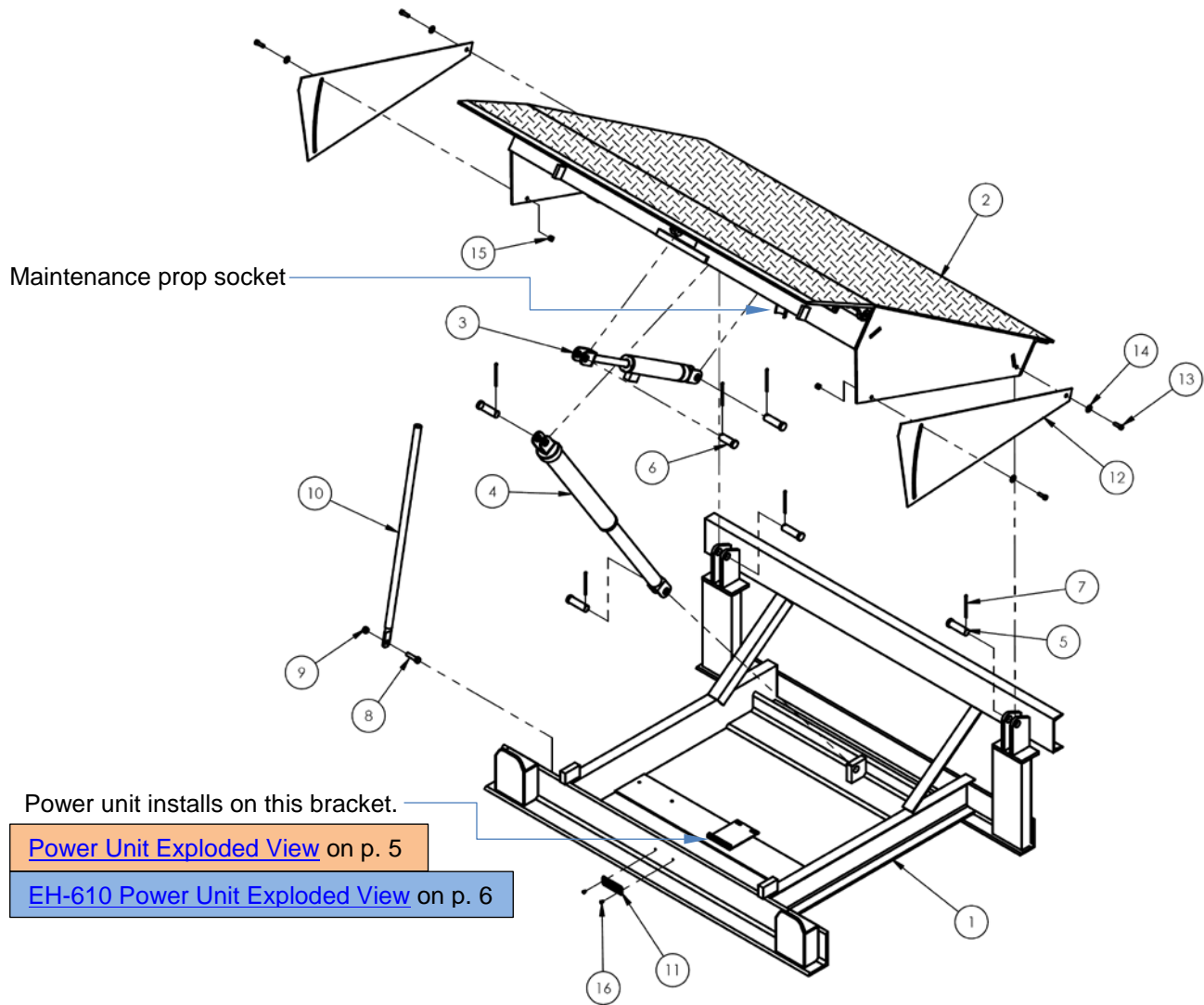

Item	Part no.	Description	Qty.	Item	Part no.	Description	Qty.
1	06-514-001	<u>Frame Weldment</u> EH-65	1	10	06-014-013	<u>Maintenance Prop</u> EH-65	1
	06-514-003	EH-66			06-014-013	EH-66	
	06-514-005	EH-68			06-014-011	EH-68	
	06-514-007	EH-610			06-014-015	EH-610	
2	06-513-020	<u>Deck Weldment</u> EH-65	1	11	99-134-003	Tag, Model no., capacity, serial no.	1
	06-513-023	EH-66		12	06-024-015	<u>Guard, side skirt</u> EH-65	2
	06-513-026	EH-68			06-024-015	EH-66	
	06-513-029	EH-610			06-024-013	EH-68	
		06-024-016	EH-610				
3	99-021-933-001	Cylinder, hydraulic, 2" x 8" piston style with clevis mounts	1	13	11107	Hex bolt, gr. A, zinc finish, $\frac{3}{8}$ "-16 x $1\frac{1}{4}$ "	4
4	06-521-001 06-521-002	Assembly, cylinder, hydraulic: EH-65; EH-66; and EH-68: 2" x 18" EH-610: 2 $\frac{1}{2}$ " x 18"	1	14	33008	Flat washer, low carbon, USS, zinc plated, $\frac{3}{8}$ "	4
5	47-112-001	Pin, clevis, 1" x 3 $\frac{1}{4}$ "	5	15	37024	Nylon insert lock nut, gr. 2, zinc finish, $\frac{3}{8}$ "-16	2
6	06-112-014	Pin, clevis, 1" x 2 $\frac{1}{2}$ "	1	16	51441	Star pin anchor, $\frac{3}{16}$ " x $\frac{3}{16}$ "	2
7	65132	Extended prong cotter pin, zinc finish, $\frac{3}{16}$ " x 3 $\frac{1}{2}$ "	6	*17	29-001-251	Bumper, laminated dock, 4.5" x 10.25" x 10"	2
8	11211	Bolt, HHCS, $\frac{1}{2}$ "-13UNCx2", zinc plated	1	*Not shown in diagram			
9	36109	Hex nut, gr. A, plain finish, $\frac{1}{2}$ "-13	1				

EH-75, EH-76, EH-78 and EH-710 Exploded View & Bill of Materials:

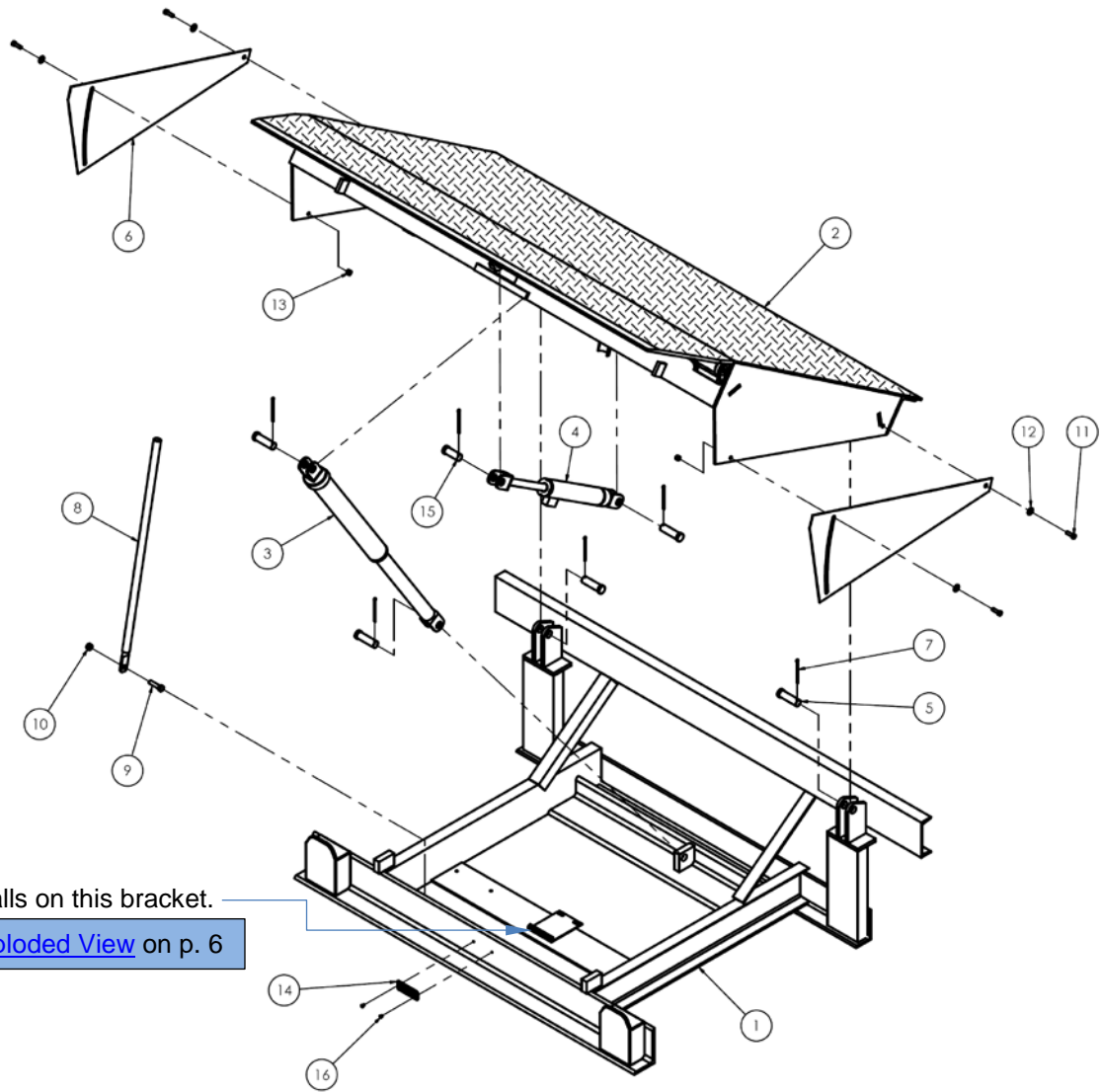

Item	Part no.	Description	Qty.	Item	Part no.	Description	Qty.
1	06-514-002	<u>Weldment, frame</u> EH-75	1	7	65132	Extended prong cotter pin, zinc finish, $\frac{3}{16}$ " x $3\frac{1}{2}$ "	6
	06-514-004	EH-76		8	<u>Maintenance prop</u>		1
	06-514-006	EH-78			06-014-013	EH-76	
	06-514-008	EH-710			06-014-011	EH-78	
2	<u>Weldment, deck</u>		1	9	11211	Bolt, HHCS, $\frac{1}{2}$ "-13UNCx2", zinc plated	1
	06-513-120	EH-75		10	36109	Hex nut, gr. A, plain finish, $\frac{1}{2}$ "-13	1
	06-513-123	EH-76		11	11107	Hex bolt, gr. A, zinc finish, $\frac{3}{8}$ "-16 x $1\frac{1}{4}$ "	4
	06-513-126	EH-78		12	33008	Flat washer, low carbon, USS, zinc plated, $\frac{3}{8}$ "	4
3	Assembly, cylinder, hydraulic:		1	13	37024	Nylon insert lock nut, gr. 2, zinc finish, $\frac{3}{8}$ "-16	2
	06-521-001	EH-75; EH-76; and EH-78: 2" x 18"					
4	99-021-933-001	Cylinder, hydraulic, 2" x 8" piston style with clevis mounts	1	14	99-134-003	Tag: model no. capacity, serial no.	1
5	47-112-001	Pin, clevis, 1" x $3\frac{1}{4}$ "	5	15	06-112-014	Pin, clevis, 1" x $2\frac{1}{2}$ "	1
6	<u>Guard, side skirt</u>		2	16	51441	Star pin anchor, $\frac{3}{16}$ " x $\frac{3}{16}$ "	2
	06-024-015	EH-75		*17	29-001-251	Bumper, laminated dock, 4.5"x10.25"x10"	2
	06-024-015	EH-76		* Not shown in diagram			
	06-024-013	EH-78					
	06-024-016	EH-710					

Power Unit Exploded View and Bill of Materials EH-65, EH-66, & EH-68

Return to [Page 3](#)

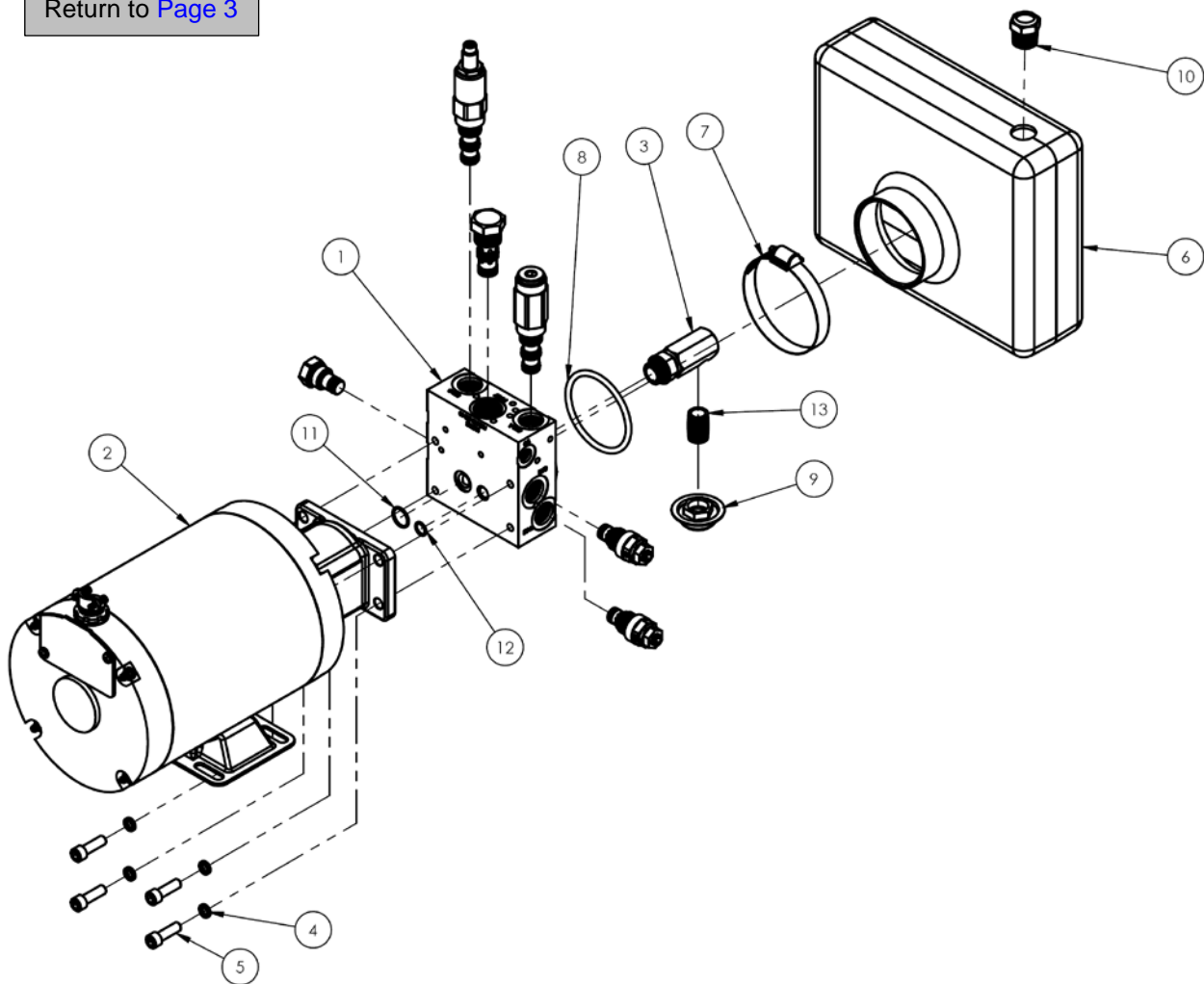

Item	Part no.	Description	Qty.
1	06-627-003	Subassembly, Manifold , Lift-Lower, Double Acting LIP (detail view on p. 7)	1
2	99-137-033-003	<u>Motor-and-Pump subassembly:</u> 208-230V AC, 3-phase, 2HP, 3450rpm, 0.180 displacement	1
	99-137-033-004	460V AC, 3-phase, 2HP, 3450rpm, 0.180 displacement	1
	99-137-013-002	208-230V AC, 1-phase, 2HP, 3450rpm, 0.122 displacement	1
	99-137-008-001	115V AC, 1-phase, 0.75HP, 1725rpm, 0.073 displacement	1
	99-137-008-002	208-230V AC, 1-phase, 0.75HP, 1725rpm, 0.073 displacement	1
3	99-116-001	Suction fitting, mini-manifold	1
4	33687	Lock washer, high collar, $\frac{5}{16}$ "	4
5	23255	$\frac{5}{16}$ "-18 x 1" socket head cap screw	4
6	06-023-003	Hydraulic tank	1
7	99-145-061	Clamp, worm gear hose, $2\frac{13}{16}$ " - $3\frac{3}{4}$ "	1
8	99-144-007	O-ring, manifold, 3" outer diameter	1
9	99-031-029	Accessories, hydraulic	1
10	01-116-003	Breather, $\frac{1}{2}$ " NPT	1
11	99-144-009	O-ring, manifold, $\frac{3}{4}$ " outer diameter	1
12	99-144-008	O-ring, manifold, $\frac{1}{2}$ " outer diameter	1
13	99-031-033	Accessories, nipple, close pipe	1

Power Unit Exploded View and Bill of Materials EH-610, EH-75, EH-76, EH-78, & EH-710

Return to [Page 4](#)

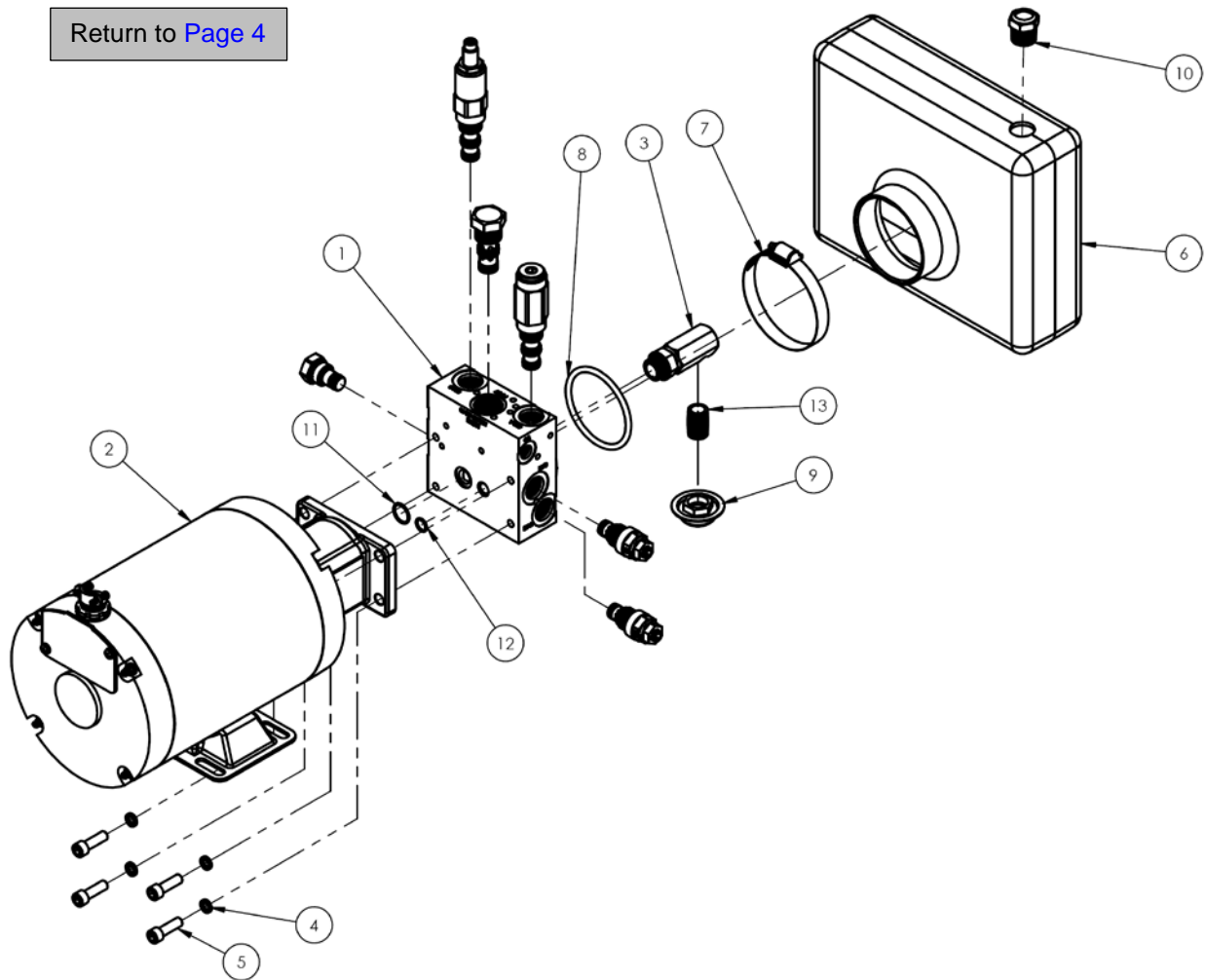

Item	Part no.	Description	Qty.
1	06-627-004	Subassembly, Manifold , Lift-Lower, Double Acting LIP (detail view on p. 7)	1
2	99-137-033-003	<u>Motor-and-Pump subassembly:</u> 208-230V AC, 3-phase, 2HP, 3450rpm, 0.180 displacement	1
	99-137-033-004	460V AC, 3-phase, 2HP, 3450rpm, 0.180 displacement	1
	99-137-013-002	208-230V AC, 1-phase, 2HP, 3450rpm, 0.122 displacement	1
	99-137-008-001	115V AC, 1-phase, 0.75HP, 1725rpm, 0.073 displacement	1
	99-137-008-002	208-230V AC, 1-phase, 0.75HP, 1725rpm, 0.073 displacement	1
3	99-116-001	Suction fitting, mini-manifold	1
4	33687	Lock washer, high collar, $\frac{5}{16}$ "	4
5	23255	$\frac{5}{16}$ "-18 x 1" socket head cap screw	4
6	06-023-003	Hydraulic tank	1
7	99-145-061	Clamp, worm gear hose, $2\frac{13}{16}$ " – $3\frac{3}{4}$ "	1
8	99-144-007	O-ring, manifold, 3" outer diameter	1
9	99-031-029	Accessories, hydraulic	1
10	01-116-003	Breather, $\frac{1}{2}$ " NPT	1
11	99-144-009	O-ring, manifold, $\frac{3}{4}$ " outer diameter	1
12	99-144-008	O-ring, manifold, $\frac{1}{2}$ " outer diameter	1
13	99-031-033	Accessories, nipple, close pipe	1

**Manifold Exploded View (06-627-003):
EH-65; EH-66; & EH-68**

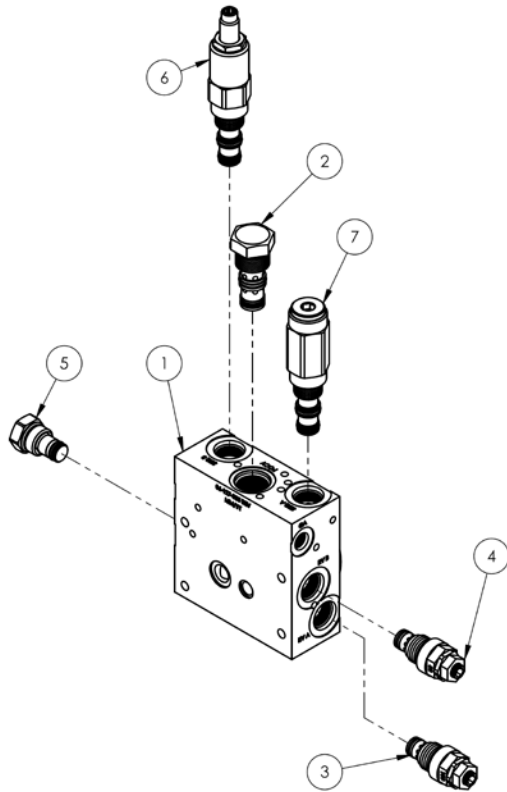

Return to [Power Unit Exploded View on Page 5](#)

Item	Part no.	Description	Qty.
1	06-127-005	Manifold, hydraulic	1
2	99-153-020	Pilot-to-close check valve	1
3	99-153-004	Valve pressure relief, 100 bar	1
4	99-153-005	Valve, pressure relief, 33 bar	1
5	99-153-011	Check valve, size 08, nose inside-out	1
6	99-153-054	Cartridge valve, sequence, 3-way, adjustable	1
7	99-153-055	Cartridge valve, sequence, 2-way with pilot	1

**Manifold Exploded View (06-627-004):
EH-610; EH-75; EH-76; EH-78, & EH-710**

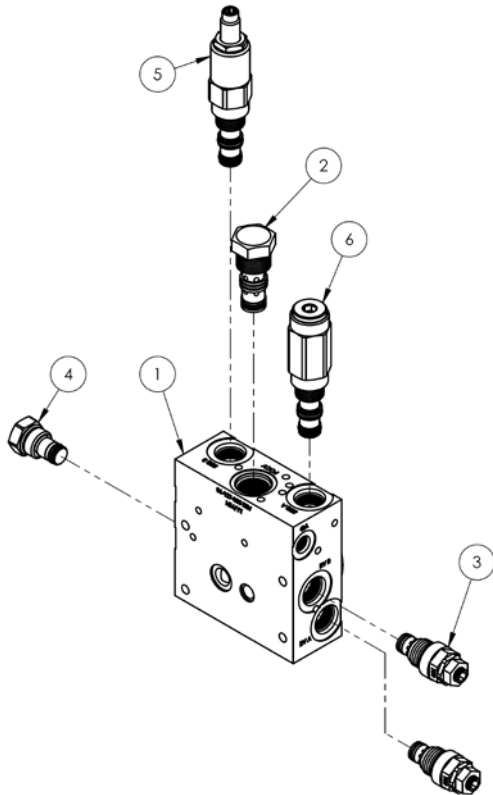

Return to [Power Unit Exploded View on Page 6](#)

Item	Part no.	Description	Qty.
1	06-127-005	Manifold, hydraulic	1
2	99-153-020	Pilot-to-close check valve	1
3	99-153-004	Valve pressure relief, 100 bar	2
4	99-153-011	Check valve, size 08, nose inside-out	1
5	99-153-054	Cartridge valve, sequence, 3-way, adjustable	1
6	99-153-055	Cartridge valve, sequence, 2-way with pilot	1

EH Dock Leveler Electrical Circuit Diagram, 115VAC, 1-phase (06-124-029 rev. B)

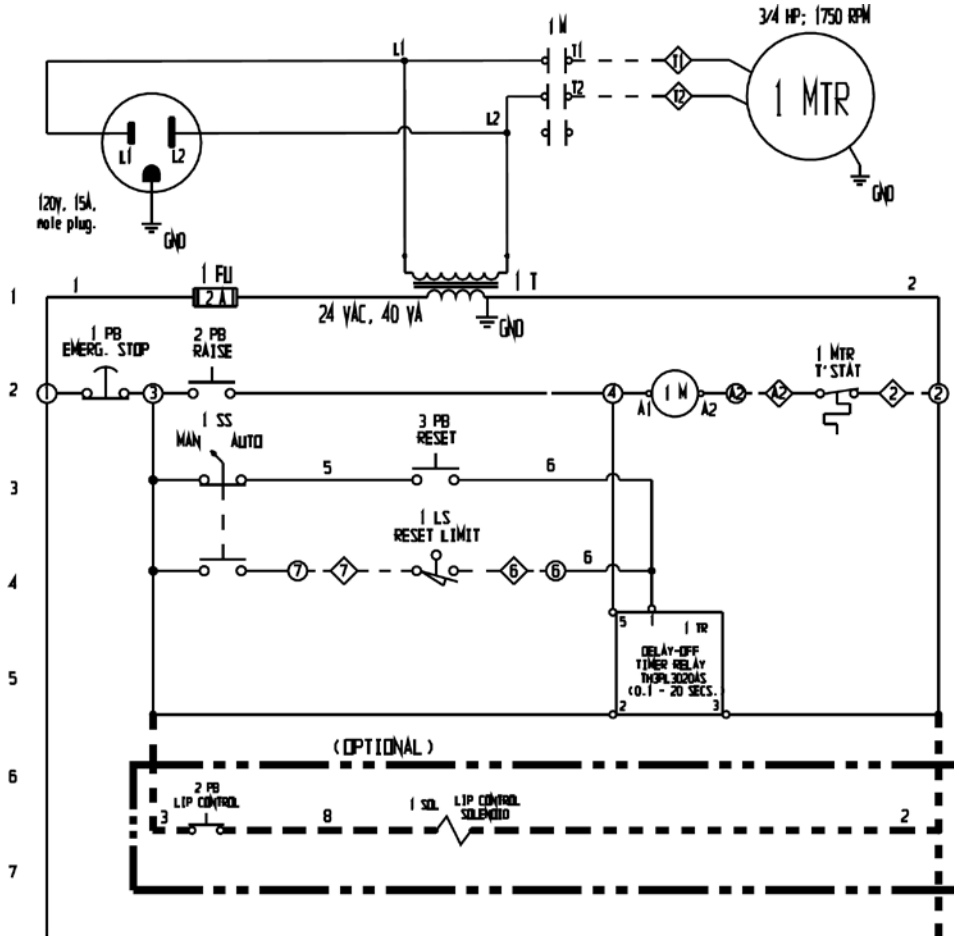

NOTES:

Installation Guideline				
Supplied to motor	Motor FLA	Fusing/Breaker	Wire Ga.	Max. run from breaker panel
115V 1Ø	12 Amps	20A	12 AWG	85 FT.

-- The wire sizing and maximum run figures given in the chart above are calculated based on the properties of stranded copper THHN wire.

Reference motor/pump assy. drawing 06-160-001

----- Indicates wire and/or components supplied by others

○ Wall Mount Control Enclosure

◇ Junction Box in Frame

WARNING Turn off all sources of electrical power and lock and tag them out before beginning this installation. 2in. conduit is recommended for this installation to allow adequate room for auxiliary equipment that might be added in the future, such as dock locks and lights. Always turn off all power sources before beginning work on this equipment.

The end-user must provide overcurrent and short circuit protection compliant with NEC guidelines and local codes.

EH Dock Leveler Electrical Circuit Diagram, 208-230VAC, 1-phase (06-124-030 rev. A)

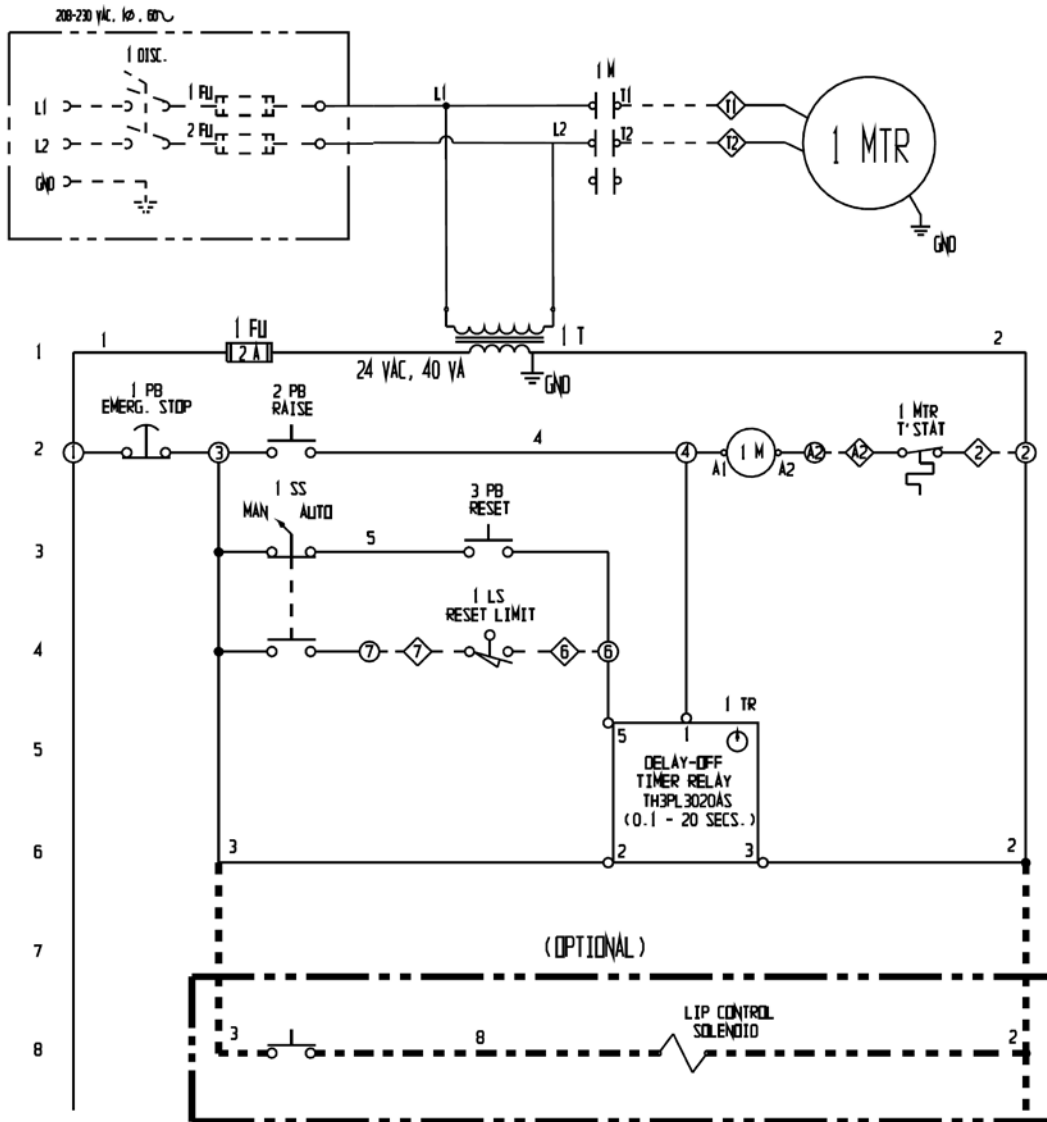

NOTES:

Reference motor/pump assy. drawing 06-160-001

----- Indicates wire and/or components supplied by others

○ Wall Mount Control Enclosure

◇ Junction Box in Frame

WARNING Turn off all sources of electrical power and lock and tag them out before beginning this installation. 2in. conduit is recommended for this installation to allow adequate room for auxiliary equipment that might be added in the future, such as dock locks and lights. Always turn off all power sources before servicing this equipment.

The end-user must provide overcurrent and short circuit protection compliant with NEC guidelines and local codes.

EH Dock Leveler Electrical Circuit Diagram, 208, 230, & 460VAC, 3-phase (06-124-031 rev. A)

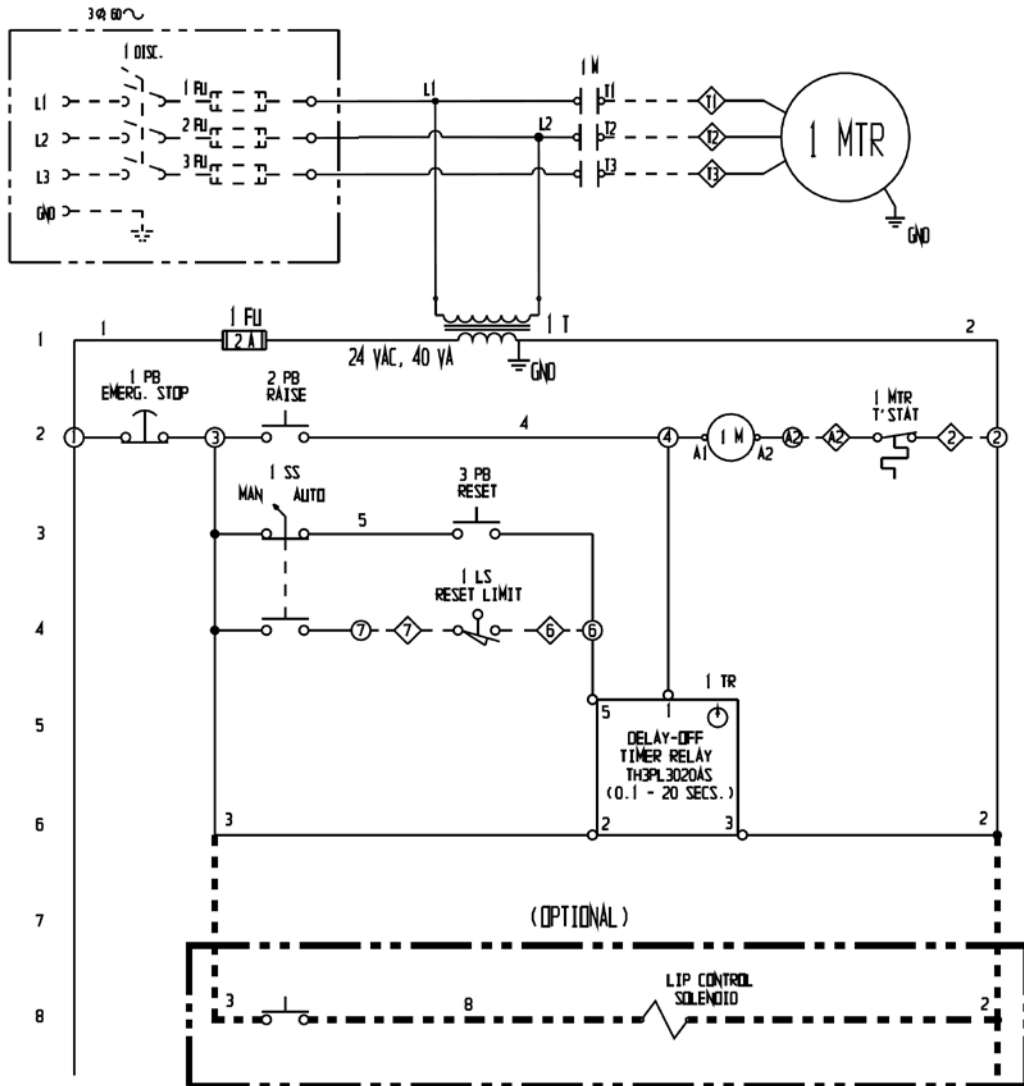

NOTES:

Reference motor/pump assy. drawing 06-160-001

----- Indicates wire and/or components supplied by others

○ Wall Mount Control Enclosure

◇ Junction Box in Frame

WARNING Turn off all sources of electrical power and lock and tag them out before beginning this installation. 2in. conduit is recommended for this installation to allow adequate room for auxiliary equipment that might be added in the future, such as dock locks and lights. Always turn off all power sources before servicing this equipment.

The end-user must provide overcurrent and short circuit protection compliant with NEC guidelines and local codes.

Electrical system operation, EH Series

The electric circuit consists of a push-and-hold motor start circuit with thermal protection. The timer circuit activates and runs the motor for approximately 10 seconds. The timer is actuated by either a limit switch in automatic mode, or by pressing the RESET button in manual mode.

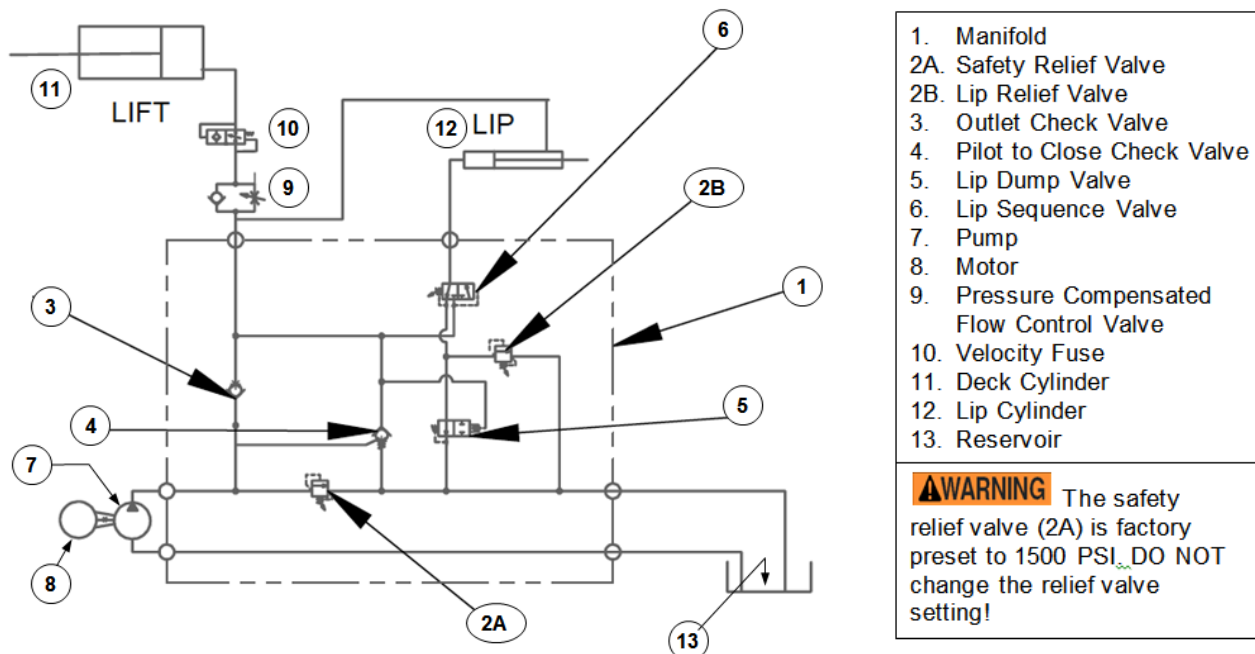

Figure 4: Hydraulic circuit

Hydraulic Circuit Sequence of Operation, EH Series [Numbers in Parentheses () Correspond to Numbers in the Diagram Above]

EH-series dock levelers are hydraulically powered through a sequence of steps. The pressure required to raise the deck varies with deck size. However, the pressure always remains below the pressure setting of the lip sequence valve (6). The sequence valve is factory set to 700 PSI, unless the deck's weight requires a different setting, and should not be changed.

Pressing the "RAISE" button activates the pump. Oil pressure increases until it equals the cracking pressure of the outlet check valve (3). The pressure closes valve (4), a pilot-to-close check valve with a 3:1 ratio. When the pilot pressure exceeds one third of the inlet pressure, the valve closes. As pressure builds in the deck cylinder, the deck rises and the lip rotates outward. When the pressure exceeds 40 PSI, the lip's dump valve, (5), closes. The dump valve is a normally open "pilot-to-close" directional valve.

As the lip rotates outward, oil from the cap end of the lip cylinder (12) is forced across the lip relief valve (2B). The pressure setting of the lip relief valve divides oil flow between the deck cylinder (11) and the lip cylinder (12), and controls the lip's movement. If the pressure is too low, the lip will not fully extend. If pressure is too high, the lip will retract too slowly and fail to return to its stowed position. The lip should completely rotate outward when the deck rises approximately 18 inches.

After the deck cylinder fully extends, hydraulic pressure continues to increase until the lip sequence valve (6) shifts. When the valve shifts, there is pressure on both sides of the lip cylinder. Because there is more pressure applied to the cap end of the cylinder than to the rod end, the lip cylinder retracts.

Releasing the RAISE button deactivates the pump and the hydraulic pressure declines. When the pump output pressure drops below one third of the lift pressure, the pilot-to-close check valve (4) opens and the deck begins to descend. A pressure-compensated flow control valve (9) controls the deck's rate of descent. Pressure continues to decrease after the deck returns to its fully lowered position. When the pressure drops below 40 PSI, the lip dump valve (5) opens which allows the lip to return to its stowed position.

The hydraulic system includes a safety device, called a velocity fuse, which prevents the deck from collapsing if system pressure suddenly drops (for example, if the flow control valve fails or a hose is punctured). The fuse is integrated into the cylinder. When the fuse closes oil cannot flow back to the reservoir.

Adjusting EH dockleveler hydraulic settings

Tools required:

- Adjustable wrench
- 1/4" hex wrench
- 5mm or 3/16" hex wrench
- 2nd person to operate the "raise" button at the control panel

Lift the deck and insert the maintenance prop

Referring to the diagram below, locate the three valves identified on the drawing to the left.

A. Sequence valve

1. Loosen the lock-nut
2. Turn the sequence-valve adjustment clockwise until it stops

B. RVB

1. Loosen the lock-nut
2. Turn the relief-valve B adjustment counter-clockwise until it feels loose.

C. RVA

1. Assuming it has not been adjusted since it left the factory - let's leave it alone for the moment.
- Now, TURN THE SELECTOR SWITCH for the dockleveler to OFF

We are ready to begin adjusting the valves.

1. Adjust timing of lip extension, which is controlled by the sequence valve (SV):

The lip should extend when the deck reaches its fully raised position. However, right now the lip will not kick out when the deck is fully raised because we increased the SV setting to the maximum in step A2 above. Now, we need to decrease the setting. To accomplish this, while your coworker presses and holds the RAISE button, turn the adjustment hex counterclockwise until the lip extends.

2. Adjust timing of lip retraction, which is controlled by Relief Valve B (RVB):

The lip should drop (retract) after the deck is fully lowered. If lip retraction timing is off, specifically if the lip retracts as the deck lowers, then the RVB setting must be increased. Raise the deck and cautiously remove the maintenance stop from its keeper below the deck. Then, release the RAISE button and allow the deck to drift down to its resting position.

- a. Use a 5mm hex wrench to turn the adjustment hex clockwise until you begin to feel resistance.
- b. Cycle the deck up and down a few times and note how quickly the lip drifts down or retracts.
- c. If the lip either
 - i. Drifts down to the retracted position while the deck is descending, OR
 - ii. Retracts too quickly when cycling the deck,
 then the adjustment hex clockwise to increase the setting. The adjustment process might require a number of cycles to fine tune. However, smooth lip retraction can be achieved with careful adjustment.

3. Adjust system pressure, controlled by Relief Valve A (RVA)

System pressure should be adjusted if: 1) the deck won't rise; or 2) the lip does not extend. Adjusting the RVA setting requires the use of a pressure gauge connected to the "deck" port on the hydraulic manifold. Increase pressure by turning the adjustment hex of RVA clockwise. Cycle the deck and observe the pressure reading on the gauge. System pressure must never exceed 1500 psi. Be sure that any adjustment made to the system pressure does not cause the motor to demand more amps than its rating. Electrical specifications for the motor appear on a data tag affixed to it.

Sequence Valve (SV):
(lock-nut and adjustment
hex) determines when
dockleveler lip extends

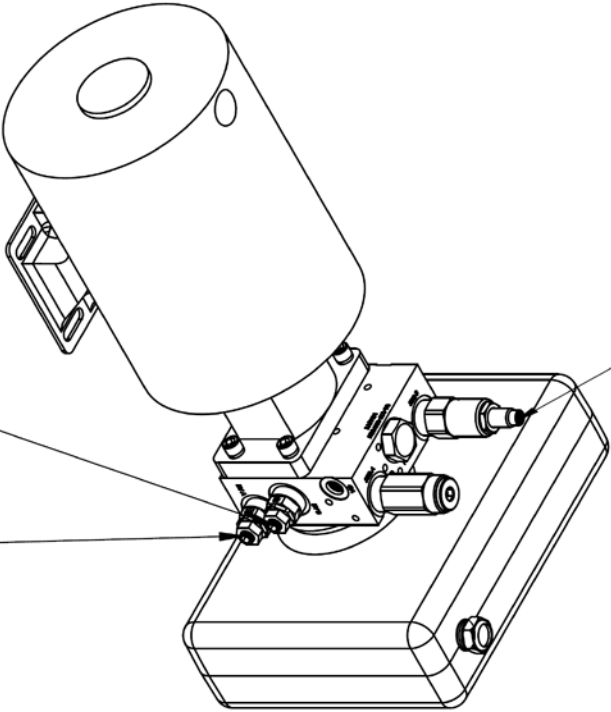

Relief-Valve B (RVB): (lock
nut and adjustment hex)
controls speed lip retraction
speed

Relief-Valve A (RVA): (lock nut
and adjustment hex) controls
max. pump pressure

RR-65, RR-66, RR-68 and RR-610 Exploded View (Bill of Materials on Following Page)

Deck shock assembly (attached to underside of item 2)
Used on RR-66, RR-68, RR-610, RR-76, RR-78, & RR-710

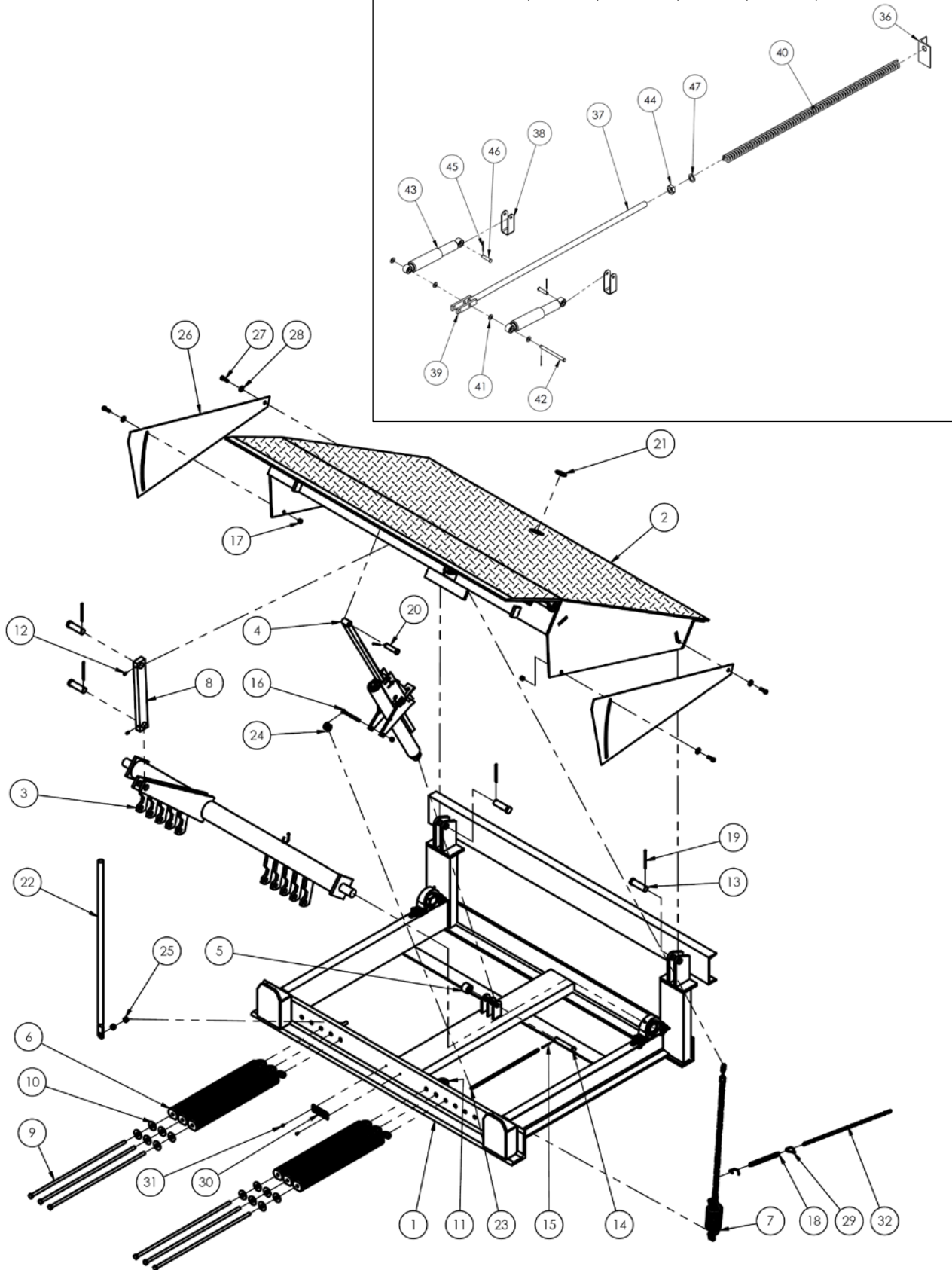

RR-65, RR-66, RR-68 and RR-610 Bill of Materials

Item	Part no.	Description	Qty.	Item	Part no.	Description	Qty.
1	07-514-002	<u>Base frame weldment</u> RR-65	1	18	07-146-006	Spring, lip retainer	1
	07-514-003	RR-66					
	07-514-004	RR-68					
	07-514-005	RR-610					
2	06-513-020	<u>Deck assembly</u> RR-65	1	19	65132	Extended prong cotter pin, zinc finish, 3/16" x 3 1/2"	4
	06-513-021	RR-66					
	06-513-022	RR-68					
	06-513-023	RR-610					
3	07-518-006	Weldment, standard trunnion	1	20	07-112-019	Clevis pin, 3/4" x 2 3/4"	1
4	07-042-001	D-comp ratchet	1	21	99-117-005	2" diameter x 1/4" steel ring	1
5	07-527-014	Subassembly, chain roller bearing	1	22	06-014-011	Frame, mechanical prop	1
6	07-646-001	Spring, subassembly, 800 cam RR-65	6	23	07-145-018	D-comp limit chain	1
		RR-66	8				
		RR-68 & RR-610	10				
7	07-646-003	Subassembly, spring chain	1	24	99-145-050	Specialty hardware, S-hook	1
8	07-016-029	Counterbalance arm	1	25	36109	Hex nut, gr. A, plain finish, 1/2"-13	2
9	<u>Screw, threaded rod</u>		6	26	<u>Guard, side skirt</u>		2
	07-145-007	RR-65			06-024-015	RR-65	
	07-145-007	RR-66			06-024-015	RR-66	
	07-145-011	RR-68			06-024-013	RR-68	
	07-145-012	RR-610		06-024-016	RR-610		
10	33016	Flat washer, low carbon, USS, zinc plated, 5/8"	12	27	11107	Hex bolt, gr. A, zinc finish, 3/8"-16x1 1/4"	4
11	01-145-011	Specialty hardware, eyelet	1	28	33008	Flat washer, low carbon, USS, zinc plated, 3/8"	4
12	5546062	Grease zerk, 3/16", straight, drive-in	2	29	99-145-013	Cold shut	3
13	47-112-001	Clevis pin, 1" x 3 1/4"	4	30	99-134-003	Data tag (model, capacity, serial no.)	1
14	28-112-031	3/4" x 4 1/2" clevis pin	1	31	51441	Star pin anchor, 3/16" x 3/16"	2
15	65080	Extended prong cotter pin, zinc finish, 1/8" x 2"	2	32	Specialty hardware, chain, trunnion chain		1
					99-145-113	RR-75	
					99-145-114	RR-76	
					99-145-115	RR-78	
				99-145-116	RR-710		
16	11119	Hex bolt, gr. A, zinc finish, 3/8"-16 x 4"	1	*33	Specialty hardware, pull chain		1
					07-145-014	RR-75	
					07-145-015	RR-76	
					07-145-016	RR-78	
				07-145-017	RR-710		
17	37024	Nylon insert lock nut, gr. 2, zinc finish, 3/8"-16	3	*34	29-001-251	Laminated dock bumper, 4 1/2" x 10 1/4" x 10"	2

* Not shown in diagram

Item	Part no.	Description	Qty.
36	07-016-065	Bracket, angle, lip rod	1
37	07-026-001	Shaft, lip adjusting rod	1
38	07-016-001	Bracket, shock absorber, formed	2
39	07-016-036	Bracket, lip adjusting rod, formed	2
40	07-146-007	Spring, plunger	1
41	33011	Flat washer, USS, plain finish, 1/2"	4
42	23-112-024	Pin, clevis, 1/2" x 6"	1
43	07-146-011	Spring/shock absorber	2
44	36219	1" - 8 plain finish hex jam nut	1
45	65080	Extended prong cotter pin, zinc finish, 1/8" x 2"	3
46	28-112-040	Clevis pin, 1/2" x 2"	2
47	33446	10Ga machine bushing, 1" x 18ga.	1

RR-75, RR-76, RR-78 and RR-710 Exploded View (Bill of Materials On Following Page)

Deck shock assembly (attached to underside of item 2)
Used on RR-66, RR-68, RR-610, RR-76, RR-78, & RR-710

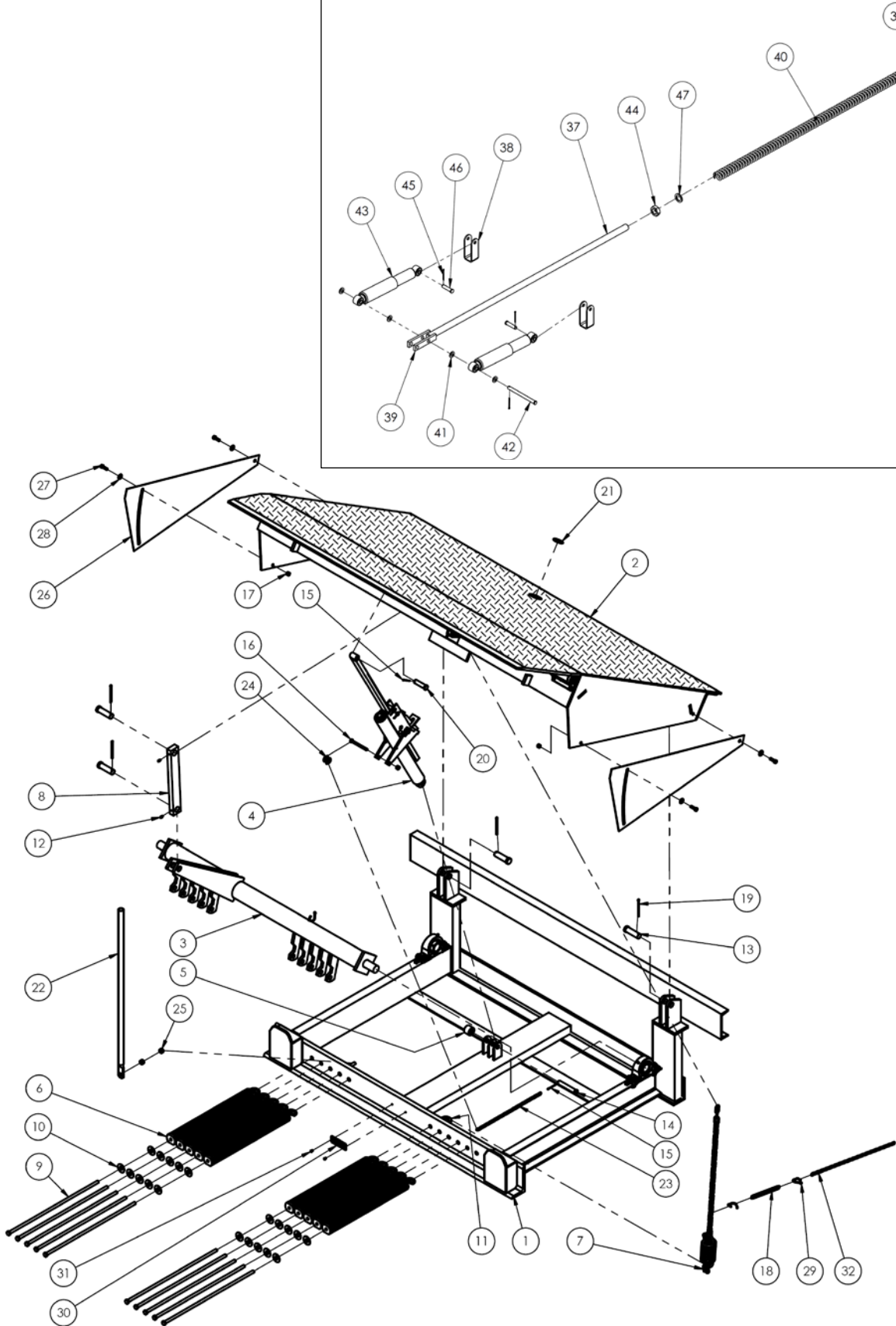

RR-75, RR-76, RR-78 and RR-710 Bill of Materials

Item	Part no.	Description	Qty.	Item	Part no.	Description	Qty.
1	07-514-006	<u>Base frame weldment</u> RR-75	1	18	07-146-006	Spring, lip retainer	1
	07-514-007	RR-76					
	07-514-008	RR-78					
	07-514-009	RR-710					
2	06-513-040	<u>Deck assembly</u> RR-75	1	19	65132	Extended prong cotter pin, zinc finish, $\frac{3}{16}$ " x $3\frac{1}{2}$ "	4
	06-513-041	RR-76					
	06-513-042	RR-78					
	06-513-043	RR-710					
3	07-518-006	Weldment, standard trunnion	1	20	07-112-019	Clevis pin, $\frac{3}{4}$ " x $2\frac{3}{4}$ "	1
4	07-042-001	D-comp ratchet	1	21	99-117-005	2" diameter x $\frac{1}{4}$ " steel ring	1
5	07-527-014	Subassembly, chain roller bearing	1	22	06-014-011	Frame, mechanical prop	1
6	07-646-001	Spring, subassembly, 800 cam	10	23	07-145-018	D-comp limit chain	1
7	07-646-003	Subassembly, spring chain	1	24	99-145-050	Specialty hardware, S-hook	1
8	07-016-029	Counterbalance arm	1	25	36109	Hex nut, gr. A, plain finish, $\frac{1}{2}$ "-13	2
9		<u>Screw, threaded rod</u> RR-75	10	26	06-024-015	<u>Guard, side skirt</u> RR-75	2
	07-145-007	RR-76					
	07-145-011	RR-78					
	07-145-012	RR-710					
10	33016	Flat washer, low carbon, USS, zinc plated, $\frac{5}{8}$ "	20	27	11107	Hex bolt, gr. A, zinc finish, $\frac{3}{8}$ "-16x $1\frac{1}{4}$ "	4
11	01-145-011	Specialty hardware, eyelet	1	28	33008	Flat washer, low carbon, USS, zinc plated, $\frac{3}{8}$ "	4
12	5546062	Grease zerk, $\frac{3}{16}$ ", straight, drive-in	2	29	99-145-013	Cold shut	3
13	47-112-001	Clevis pin, 1" x $3\frac{1}{4}$ "	4	30	99-134-003	Data tag (model, capacity, serial no.)	1
14	28-112-031	$\frac{3}{4}$ " x $4\frac{1}{2}$ " clevis pin	1	31	51441	Star pin anchor, $\frac{3}{16}$ " x $\frac{3}{16}$ "	2
15	65080	Extended prong cotter pin, zinc finish, $\frac{1}{8}$ " x 2"	2	32	99-145-113	Specialty hardware, chain, trunnion chain RR-75	1
						RR-76	
						RR-78	
						R-710	
16	11119	Hex bolt, gr. A, zinc finish, $\frac{3}{8}$ "-16 x 4"	1	*33	07-145-014	Specialty hardware, pull chain RR-75	1
						RR-76	
						RR-78	
						RR-710	
17	37024	Nylon insert lock nut, gr. 2, zinc finish, $\frac{3}{8}$ "-16 RR-75	3	*34	29-001-251	Laminated dock bumper, $4\frac{1}{2}$ " x $10\frac{1}{4}$ " x 10"	2
		RR-76, RR-78, & RR-710	5				

* Not shown in diagram

Item	Part no.	Description	Qty.
36	07-016-065	Bracket, angle, lip rod	1
37	07-026-001	Shaft, lip adjusting rod	1
38	07-016-001	Bracket, shock absorber, formed	2
39	07-016-036	Bracket, lip adjusting rod, formed	2
40	07-146-007	Spring, plunger	1
41	33011	Flat washer, USS, plain finish, $\frac{1}{2}$ "	4
42	23-112-024	Pin, clevis, $\frac{1}{2}$ " x 6"	1
43	07-146-011	Spring/shock absorber	2
44	36219	1" – 8 plain finish hex jam nut	1
45	65080	Extended prong cotter pin, zinc finish, $\frac{1}{8}$ " x 2"	3
46	28-112-040	Clevis pin, $\frac{1}{2}$ " x 2"	2
47	33446	10Ga machine bushing, 1" x 18ga.	1

Installation

WARNING

Never work under a dock leveler unless the maintenance prop is installed in its socket.

NOTICE

The Dock Leveler must be level to function properly. Do not modify the dock leveler to fit in a pit.

1. Measure the pit's dimensions.
2. Using steel shims, position shims under the frame to prevent frame distortions and flex so the Dock Leveler's final, resting position meets the following:
 - The Dock Leveler should be level.
 - The Dock Leveler should be against the rear pit curb angle.
 - The platform should be centered from side to side within the pit.
 - The Dock Leveler's rear channel must be flush with the rear curb angle.

NOTICE

Do not allow the Dock Leveler to be above the pit's rear curb angle.

3. With the shims in position, skip weld the rear hinge channel to the rear curb angel, 4 inches every 8 inches.
4. Grind welds smooth.

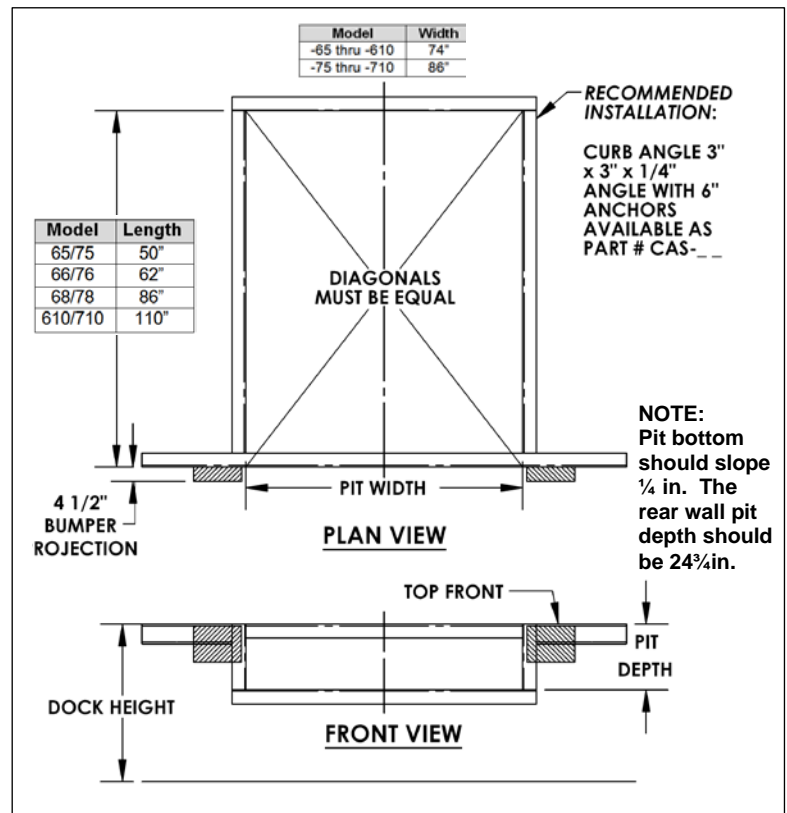

Operation, EH Series

The Dock Leveler has an electric motor directly coupled to a gear-type hydraulic pump to pressurize the hydraulic system. Hydraulic pressure allows the cylinders to lift the platform and extend the lip. The hydraulic control components are housed within a hydraulic manifold, bolted directly onto the gear pump. All hydraulic components are rated for 3,000 psi working pressure.

Notable power unit parts include:

1. Electric motor: The A/C motor operates on either single-phase or 3-phase AC, depending on the motor ordered.
2. Gear pump: The pump shaft is coupled directly to the electric motor shaft.
3. Pressure relief valve: At pressures greater than 1,500 psi, fluid flows back into the reservoir.
4. Lip relief valve: The adjustable valve controls the Lip's retract rate after the platform has risen.
5. Check valve: It prevents fluid backflow through the pump.
6. Pilot-operated check valve: This valve is closed while the leveler rises and it opens when the pilot pressure drops to less than 1/3 of the inlet pressure, causing the deck to descend.

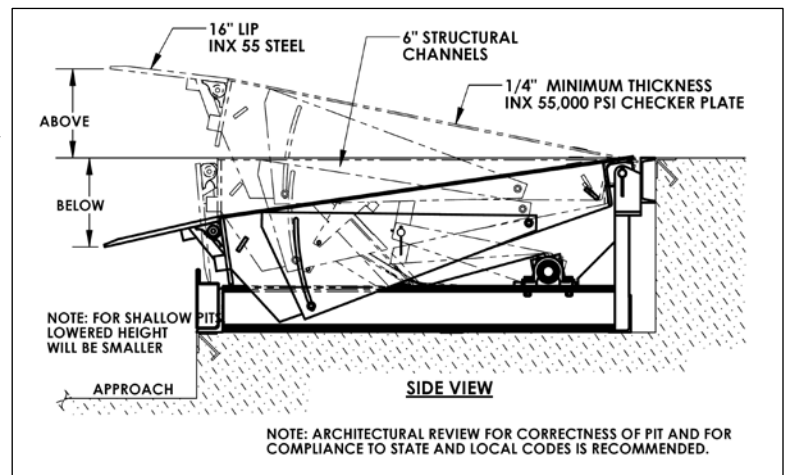

7. Pilot-to-close, two-position valve: Normally open, this valve closes when the pilot pressure exceeds 40 psi. It holds the lip in the extended position until either the platform or the lip is physically supported.
8. Pilot-operated sequence valve: When system pressure reaches ~700 psi, the valve shifts to extend the lip.
9. Pressure-compensated flow control valve: Located in the deck cylinder's port, it regulates the deck's lowering rate.
10. Hydraulic cylinders:
 - a. Deck cylinder - A displacement-style cylinder with a bleeder valve located at the top end raises and lowers the deck. The bleeder valve allows air to be removed from the hydraulic system.
 - b. Lip cylinder - A double-acting cylinder extends and retracts the Lip.
11. Safety velocity fuse: Located in the deck cylinder's hose port, it closes quickly in the event of a catastrophic hose failure to prevent the deck from collapsing. The deck remains elevated until pressure is reapplied to the cylinder.
12. Hydraulic fluid: The system uses HO150 hydraulic fluid. Any anti-wear hydraulic oil with a viscosity grade of 150 SUS at 100°F (ISO 32 at 40°C), such as: AW 32 or a non-synthetic transmission fluid is acceptable.

Pressing the RAISE button activates the dock leveler. The motor turns and spins the hydraulic gear pump. Oil is drawn from the reservoir through the suction filter and into the pump. The pump forces pressurized oil through the hydraulic manifold to the deck cylinder. Pressure first acts on the deck cylinder causing it to extend, and then, causes the lip cylinder to extend. When the RAISE button is released, the lip remains extended and the deck descends at a rate determined by the pressure-compensated flow control valve. The lip eventually rests on the back end of the trailer. If the deck descends and contacts the supporting frame, a limit switch is engaged. When in "AUTO" mode, the limit switch causes the leveler to reset itself to the resting/cross-traffic position by turning on the motor for approximately 3 seconds. This brief period is long enough to raise the deck and retract the lip. If the unit is in "MANUAL" mode, engaging the limit switch only causes the lip to drop.

Issues & Solutions: additional solutions are found under Inspections and Maintenance.

Before beginning work to resolve either of the issues identified below, unload the dock leveler and apply the maintenance prop. To install the prop, press and hold the RAISE button. Continue to hold the button after the deck reaches its maximum elevation. A second person should install the free end of the maintenance prop into the socket on the underside of the deck. Release the RAISE button to allow the maintenance prop to seat firmly in the socket.

1. If the deck does not rise while the pump runs, remove the pilot-to-close check valve. Inspect and clean the valve in the following manner:
 - a) Locate the pilot-to-close check valve, which is identified with the number "4" on the hydraulic manifold, and remove it from the manifold.
 - b) Inspect the valve for contaminants. Also inspect the o-rings and back-up washers for cuts, tears, or other damage.
 - c) Immerse the valve in mineral spirits or kerosene. Use a thin tool, like a small screwdriver or a small hex wrench, to push the check ball in several times from the bottom end of the valve. The ball should move freely. If it sticks in, the valve might be defective. Replace the valve if the ball still does not move freely after cleaning. Blow the valve off with compressed air, while simultaneously pushing the check ball in-and-out.
 - d) Inspect the bottom of the valve cavity in the manifold (the chamber in the manifold that houses the valve) for debris. Clean the valve cavity as needed.
 - e) Reinstall the valve. Tighten the valve in the manifold to approximately 20 lb-ft of torque.
2. If the platform lowers extremely slowly, or not at all, the velocity fuse of the deck cylinder might be closing. This is typically caused by air in the cylinder. To correct the problem, bleed air from the hydraulic system:
 - a) Hold a rag over the bleeder valve of the deck cylinder. The valve looks like a grease zirk. Use a ¼ in. wrench to turn the valve about 1/2 turn. Jog the motor by quickly pressing and releasing the RAISE button. Oil and air will sputter from the valve. Continue this process until air no longer escapes from the valve; then close the valve.

Modes of Operation, EH Series

The leveler can be operated in either of two modes—automatic or manual. Before using the leveler, confirm normal operation by running the leveler through a complete cycle:

- 1) Automatic mode: Press and hold the "RAISE" button on the remote control box. The deck will rise to its maximum elevation and then the lip will extend. When the lip fully extends, release the "RAISE" button. The deck should

lower smoothly until the lip rests on the truck bed. The deck will descend to the fully lowered configuration when the truck pulls away from the dock leaving the lip unsupported. The power unit will restart and raise the deck to maximum elevation; the lip will lower; the power unit will shut off; and the deck will settle in to its stored position flush with the surrounding surface.

NOTICE DO NOT operate the dock leveler in automatic mode if the truck bed is below the level of the dock.

2) Manual mode: Use the leveler in this mode if a truck bed is below dock level. In manual mode, the dock leveler functions nearly identically to automatic mode. However, the power unit does not automatically start to return the deck to the stored position when the leveler reaches the lower limit. Instead, after a truck leaves the deck descends to its fully lowered position and the lip drops to avoid being damaged by the next truck.

“RESET” button: press the button to automatically return the leveler to the stored position while in manual mode.

3) To put the leveler into stored configuration, from either manual or automatic mode, while a truck occupies the loading dock:

- a) Press and hold the “RAISE” button until the deck reaches its maximum elevation;
- b) Release the button;
- c) The leveler will return to its stored position.

4) (Optional) Lip control: “LIP” button on the remote control extends the lip. First, press the “RAISE” button to elevate the deck sufficiently that the lip will not contact the back of the truck as it extends; then press the “LIP” button to extend the lip. Release the “RAISE” and “LIP” buttons and the lip will settle on the bed of the truck. If the RAISE button is released but you continue to hold the LIP button, the leveler will maintain its position. Release the LIP button to allow the lip to settle on the truck bed.

5) Emergency stop button: Pressing this button cuts all power to the unit. ***If the emergency stop button is pressed at any time during the cycle of operation, the leveler will return to its stored position.*** Pull out the emergency stop button to reset the switch and restore power.

Operation, RR Series

NOTICE Do not leave any cargo or equipment on the Dock Leveler deck at any time.

Before Use

1. When the truck is against the Dock Lever’s bumpers, chock the truck’s wheels on both sides.
2. Verify the truck’s cargo area has ample room to accept the Dock Leveler lip. The lip will require about twelve inches (12”) beyond the bumper for the standard sixteen inch (16”) lip.
3. If the cargo area is not sufficiently clear, clear the area.
4. Verify the lip is in the vertical position and securely behind the lip keepers.

WARNING Verify the people and equipment are clear of the leveler. The deck will rise and the lip will automatically extend into the trailer.

5. If the deck is below dock height, release the pull and raise the deck a few inches above the dock floor.
6. Walk on the deck to lower it until the entire lip is setting on top of the trailer’s floor.
7. For Models with the ES Option: If the trailer floor is below the dock’s floor, the Emergency Stop’s safety legs need to be retracted. Pull the ES ring, the rear-most ring on the Dock Leveler, to retract the safety legs and completely lower the lip onto the trailer’s floor. Release the ES ring.
8. Load / unload the cargo.

After use

NOTICE If the truck departs before the dock leveler is retracted, the lip will fall to the down position. The lip might not be in the keepers.

1. Pull the recessed handle, releasing the deck, until the lip clears the truck.
2. After the deck completely retracts, walk on the deck until it returns to floor height.
3. Verify the lip is behind the keepers.
4. The trailer’s overhead door and/or the building may now be closed and the wheel chocks removed.

Troubleshooting, EH Series

The following information is provided to diagnose and correct issues with EH-series dock levelers.

Issue	Cause	Solution
Motor does not run and deck does not rise	<ol style="list-style-type: none"> 1. Emergency stop button activated (pressed) 2. Transformer fuse blown or tripped circuit breaker 3. No supply voltage 4. Bad control transformer 5. Malfunctioning motor relay coil 6. Malfunctioning RAISE push button 7. Thermal-overload switch tripped 	<ol style="list-style-type: none"> 1. Pull up emergency stop button. 2. Replace fuse or reset circuit breaker. 3. Test voltage with meter, Check fuses, breakers, and overloads. 4. Check for 24VAC; replace if bad. 5. Test with meter; replace if bad. 6. Test with meter; replace if bad. 7. Wait for motor to cool.
Motor runs, but deck does not rise and don't hear motor running	<ol style="list-style-type: none"> 1. Motor rotation is wrong 2. Pumps failing to pressurize hydraulic system 3. Load on the deck (leveler will only lift its own weight) 	<ol style="list-style-type: none"> 1. Confirm that motor turns clockwise opposite the shaft end. 2. Contact the factory. 3. Unload the deck.
Motor hums or pump squeals but deck does not rise or rises very slowly	<ol style="list-style-type: none"> 1. Excessive voltage drop to motor because power cord wire size too small, wire length too long, or incoming voltage too low. 2. Motor running slowly, is hot, or lost one phase (3-phase motors) 4. Pressure relief valve opening at full system pressure. 5. Pilot-to-close check valve failing to close 6. Load applied to deck 	<ol style="list-style-type: none"> 1. Check power installation. Check incoming voltage <i>while motor running</i>. 2. Check voltage on all legs; check fuses; repair as necessary. 4. Check for frame damage or binding at the deck hinge, etc. Check for platform overload condition. 5. Remove valve and inspect. 6. Remove load from deck.
Deck does not automatically return to stored position when truck leaves dock	<ol style="list-style-type: none"> 1. Auto/Manual switch in manual position 2. Defective limit switch (deck fails to engage the below dock limit switch, or switch malfunctioning) 3. Defective timer, or timer period set too short 4. Bad (AUTO/Manual) selector switch contact block 	<ol style="list-style-type: none"> 1. Move switch to "auto" position 2. Change auto/manual switch to Manual mode and press RESET button. 3. Check the timer setting. Test for timer output and replace if bad. 4. Test with meter; replace if bad.
Deck does not lower	<ol style="list-style-type: none"> 1. Velocity fuse, item 10, in deck cylinder is locked. 2. Pressure-compensated flow control valve stuck. 	<ol style="list-style-type: none"> 1. Press and release RAISE button to unlock fuse. If problem persists, check for air in oil. 2. Replace valve.
Lip retracts too quickly causing rough action	Lip relief valve, item #2B, pressure setting too low	Turn adjustment on valve clockwise (quarter turn or less)
Lip does not retract	Lip relief valve, item #2B, pressure setting too high	Turn adjustment on valve counterclockwise (quarter turn or less)
Lip retracts before contacting truck bed	<ol style="list-style-type: none"> 1. Lip relief valve, item #2B, pressure setting too low 2. Faulty lip cylinder, item #12, 3. Faulty power unit 	<ol style="list-style-type: none"> 1. Turn adjustment on valve clockwise (quarter turn or less) 2. Repair or replace 3. Repair or replace
Lip does not extend when deck reaches top position	<ol style="list-style-type: none"> 1. Defective lip cylinder 2. Faulty power unit 	<ol style="list-style-type: none"> 1. Repair or replace 2. Repair or replace

Inspections and Maintenance: EH-Series

Before beginning maintenance, secure the deck in the raised configuration with the maintenance prop. The process requires 2 people: one person presses and holds the RAISE button to keep the deck raised with the lip extended, while the second person pivots the maintenance prop to align the free end of the prop with the socket on the underside of the deck.

⚠ WARNING DO NOT use the Dock Leveler if adjustments and/or repairs are incomplete! Return it to service ONLY after finishing all necessary repairs and adjustments. The reader should understand the difference between necessary adjustments and repairs, and modifications.

An adjustment is a simple correction that restores the lifter to normal operating condition, such as tightening loose fasteners, or removing dirt or other debris from the surface of the dumper; a repair refers to replacing worn parts with new, factory-approved replacement parts.

A modification is a change that alters the machine from normal operating condition, like bending the structural members or removing a part or several parts. **NEVER modify the unit. Modifications automatically void the Limited Warranty and might make the leveler unsafe to use.**

NOTICE Regular maintenance is essential to keep the dock leveler operating properly. ONLY use ISO AW-32 hydraulic fluid or its equal in the hydraulic system.

Inspections:

- (A) Inspect daily for the following:
- 1.) Frayed wires and loose conduit fittings
 - 2.) Damage and deformation of the structural members, cylinder brackets, etc.
 - 3.) Run the leveler through a complete cycle. Listen for unusual noises and watch the leveler and lip for binding or unusual movement, or evidence thereof, during operation.
 - 4.) Confirm that the side skirt guards are securely fastened to the deck.
- (B) Inspect the following each month:
- 1.) Oil leaks – check the hoses, cylinders, fittings, etc. for oil leaks. Also check the oil level in the reservoir. Oil should be 1" to 1½" below the fill hole in the reservoir. See Inspections and Maintenance for oil specifications.
 - 2.) Hydraulic hoses and electrical wiring - look for Worn or damaged hydraulic hoses and electrical wires.
 - 3.) Hinge and cylinder pivot points – check for excessive wear at pivot points.
 - 4.) Welds – check all welds for cracks and signs of metal fatigue, especially at the hinge.
 - 5.) Mode functions – cycle the leveler through each mode (AUTO and Manual) to confirm proper functioning in both modes. Carefully watch and listen to the leveler during operation. The leveler should operate without unusual noises or movement.
 - 5.) Limit switch – confirm normal operation of the below-dock limit switch in AUTO mode.
 - 6.) Hardware – check all hardware/fasteners, especially pivot point pins and pin retaining hardware.
 - 7.) Anchorage – closely examine the frame, anchor bolts, and the concrete around the anchor bolts for cracks, warping, etc.
 - 8.) Labels – confirm that each label is in place and in good condition.
 - 9.) Leveler surfaces - clean dirt and debris from the surfaces of the leveler, especially debris underneath and around the power unit.
- (C) Yearly Maintenance
- NOTE:** Usage and environment are significant factors affecting how frequently maintenance must be performed.
- 1.) Grease the lip hinge and all cylinder pivot points.
 - 2.) The oil should be changed if the oil darkens, becomes gritty, or turns a milky color (indicating the presence of water). Replace with anti-wear hydraulic oil with a viscosity grade of 150 SUS at 100°F, (ISO 32 at 40°C). E.g. AW 32 or HO 150 hydraulic oil or a non-synthetic transmission fluid. Synthetic transmission fluid can be used after flushing the system with the synthetic fluid prior to filling the reservoir.

Inspections and Maintenance: RR-Series



Any debris in, around, or under the Dock Leveler may impede its actuation. In some cases, an operator and/or equipment on top of the Dock Leveler may slide off and fall outside onto the ground causing damage and/or serious injury.

Before beginning maintenance, secure the deck in the raised configuration with the maintenance prop. The process requires 2 people: one person presses and holds the RAISE button to keep the deck raised with the lip extended, while the second person pivots the maintenance prop to align the free end of the prop with the socket on the underside of the deck.

Every Use

- Inspect the Dock Leveler operation.
- Clear the debris. Debris can be found between the Dock Leveler and the pit walls.

Monthly

- Verify labels are present, legible and securely attached. Request replacements from vendor as necessary.
- Remove all debris from the pit. Clean the lip hinge and the lip operating mechanism. Wipe dirt and material from the ratchet mechanism including the ratchet and paw. Clean the deck hinge.
- Inspect pull chain(s). They should pull without obstruction. The chain should not have excessive wear. Replace as necessary.
- Using a graphite based oil, oil all moving parts liberally. Include the hooking point at the end of the springs. The only exception is the ratchet bar and the locking paw which should not be oiled.
- Grease the following Zerk fittings with a lithium base grease:
 - Lip hinge
 - Pillow block at ends of trunnion
 - Rotating cam in center of Dock Leveler deck
 - If unit is equipped with safety stops grease both sides
- Inspect the springs.
- Inspect all welds for cracks and signs of metal fatigue, especially at the hinge.



The springs are under high tension. If quickly released or pried loose, the springs can cause equipment damage and/or serious injury.

- Springs should not be corroded or rusty. Replace as necessary.
- Springs ends should be secured at either end.
- Inspect the Dock Leveler operation. If adjustments are needed, see below.
- If paint has chipped, prepare the surface and paint.

For RR Models with the ES Option:



If the pull chains, safety legs and safety leg's springs are hindered with debris or have excessive wear, the Dock Leveler will lower and bottom out during usage. Any persons or equipment on the Dock Leveler may slide off and fall causing injury and/or equipment damage.

- Inspect the linkage operation.
 - The return spring on the safety legs should be functioning and securely connected.
 - The D-rings guiding the Release Pull Chain should be greased. The chain's travel should be unobstructed.

Adjusting Spring Tension: RR-Series

Deck Lifting Mechanism

When adjusting the spring tension, stretch the springs to the same length. This will unify the spring force acting on the lifting mechanism. The lifting motion will be more uniform.

The deck's lifting speed impacts the lip extension. The deck's momentum provides the extra energy to extend the Lip outward. Hence, if the lifting speed is too slow, the lip will not extend.

Uniformly increase the spring force by uniformly lengthening each springs length until the lip extends.

Lip Extending Mechanism

Pulling the lip chain engages the lip's Counterbalance Spring and rotates the lip outward. The appropriate compression in the spring is important for this actuation. The spring's force should be maximized while still having the lip fall back to the vertical position. Too much spring force and the lip will not return to its stowed, vertical position.

Perform the following sequence of steps until the spring force is maximized and the lip still returns to its stowed, vertical position.

Adjustment Sequence

1. Grab the lip end and manually extend lip.
2. Release the lip.
3. If it falls to the vertical position, tighten spring nut clockwise.

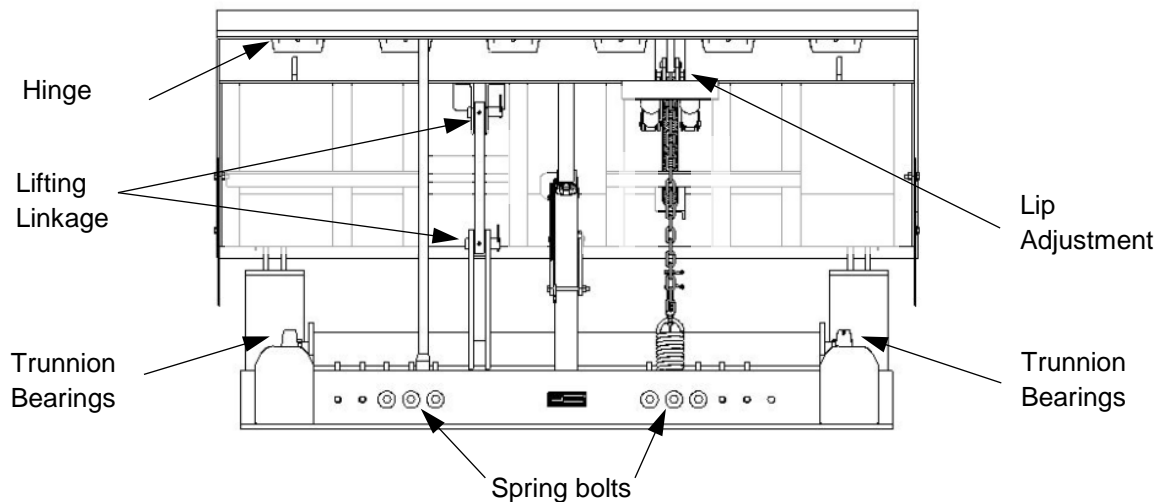

Labeling Diagrams

Your dock leveler should always be labeled as shown in the diagram. Replace any label that is damaged, missing, or not easily readable.

RR series dock levelers

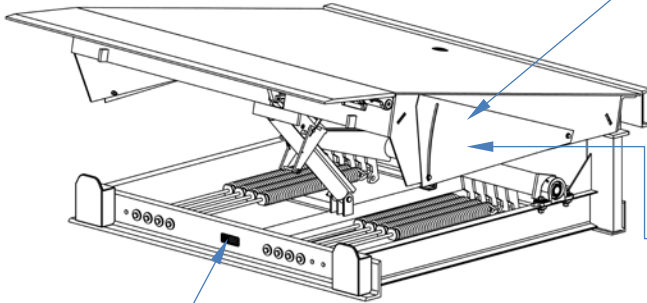

Label 288:

CAUTION	ATENCIÓN	ATTENTION
DO NOT OPERATE BOARD UNTIL TRUCK IS SPOTTED AGAINST BUMPERS. Keep feet or load off dock when pulling release chain. Consult owners manual before working on dock leveler.	NO OPERE LA TABLA HASTA QUE EL CAMIÓN ESTE ASEGURADO CONTRA LOS TOPES. Mantenga los pies y la carga fuera del andén cuando se suelte la cadena. Consulte el manual del propietario antes de usar el nivel del andén.	NE PAS ACTIVER LA PLATE-FORME AVANT QUE LE CAMION NE SOIT GARE CONTRE LES PARE-CHOCES. Éloigner ses pieds ou le chargement de la plate-forme lors du retrait de la chaîne. Consulter le manuel d'utilisation avant de travailler sur l'équipement de niveau.
OPERATING INSTRUCTIONS (1) Pull and hold chain in extended position until lip extends and board's upward movement stops. (Do not extend release board in actuated from approximately floor level position or below.) (2) Release chain. (3) Immediately walk on board to lower to truck bed after raising as lip is only momentary hold in extended position. If board does not raise or lip fails to extend, consult your owner's manual for adjustment instructions.	INSTRUCCIONES DE OPERACIÓN (1) Extiende y mantenga la cadena en la posición de extensión hasta que el borde se extienda y el movimiento de la tabla se pare. (2) Suelta la cadena. (3) Camine en la tabla inmediatamente para que la tabla se apoye en el camión ya que el borde solo se aguantará en la posición de extensión momentáneamente. Si la tabla no se eleva o el borde no se extiende consulte con el manual del propietario para las instrucciones de ajuste.	INSTRUCTIONS DE FONCTIONNEMENT (1) Tirer et tenir la chaîne en position étendue jusqu'à ce que le rebord s'étende et le mouvement ascensionnel s'arrête. (Le rebord ne s'étendra que si la plate-forme est activée lorsqu'elle est approximativement au niveau du sol ou plus basse.) (2) Lâcher la chaîne. (3) Marcher immédiatement sur la plate-forme afin qu'elle s'appuie sur la plate-bande du camion après l'élevation ainsi que le rebord est momentanément en position étendue. Si la plate-forme ne s'élève pas ou si le rebord ne s'étend pas, consulter le manuel d'utilisation pour les instructions d'ajustage.
Vestil Manufacturing Corporation, Angola, IN 46703, Ph: (260) 665-7586 • Fax: (260) 665-1339		
288 rev 0028		

Data tag 003:

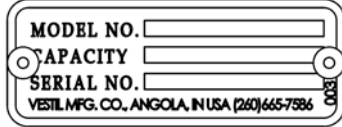

Label 367:

CAUTION	ATENCIÓN	ATENCIÓN
REST LIP ON TRAILER or lip will drop below dock height	DECANSE EL LABIO EN EL REMOLQUE o el labio se caera por debajo del andén	POSER LÈVRE SUR REMORQUE ou levre tombera au-dessous du quai
VESTIL MANUFACTURING CORPORATION • Phone (260) 665-7586 • Fax (260) 665-1339 • www.vestil.com		
367 rev 0008		

EH series dock levelers

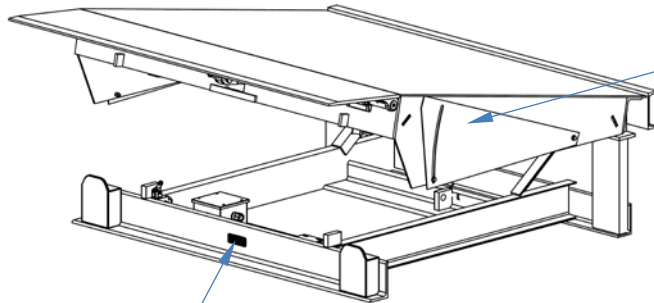

Data tag 003:

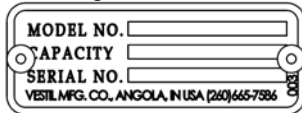

Label 367:

CAUTION	ATENCIÓN	ATENCIÓN
REST LIP ON TRAILER or lip will drop below dock height	DECANSE EL LABIO EN EL REMOLQUE o el labio se caera por debajo del andén	POSER LÈVRE SUR REMORQUE ou levre tombera au-dessous du quai
VESTIL MANUFACTURING CORPORATION • Phone (260) 665-7586 • Fax (260) 665-1339 • www.vestil.com		
367 rev 0008		

Label 584: Above control buttons

**REMOVE PLUG AND INSTALL BREATHER CAP
QUITE EL TAPON INSTALE LA TAPA DEL RESPIRADERO
DÉBOUCHER ET INSÉRER BOUCHON RENIFLARD**

584

Label 206: Applied to oil tank near fill plug

ISO 32 / 150 SUS
HYDRAULIC OIL OR NON-SYNTHETIC TRANSMISSION FLUID
ACEITE HIDRAULICO O LIQUIDOS DE TRANSMISION NO SINTETICOS
HUILE OU LIQUIDE HYDRAULIQUE NON-SYNTHÉTIQUE

206
Rev. 1003
VESTIL MANUFACTURING CORPORATION • Phone (260) 665-7586 • www.vestil.com

Label 483: On control box

When servicing truck below dock height, set the selector switch to "MAN".
Cuando se trabaja con el camión bajo el andén, programe el selector en modo "MAN".

MAN	AUTO	EMERG. STOP / INTERRUMPR
	+	+
MODEL / MODELO		RAISE / ELEVAR
SERIAL NUMBER / EL NÚMERO DE SERIE		
SAFETY INSTRUCTIONS / INSTRUCCIONES DE SEGURIDAD		
1.) For trucks below dock height, make the selector to "MAN" to prevent automatic re-raise. 2.) The vehicle which must be checked before entering the dock, per OSHA (1910.146). 3.) Block off the dock's approach to truck and hold traffic before doing maintenance or repairs.		
1.) Para remolques más bajos que el andén, programe el selector a "MAN" para prevenir un re-levanto automático. 2.) Las unidades del remolque deben de estar paradas antes de entrar al remolque, per OSHA (1910.146). 3.) Bloquear el acceso al andén al tráfico de camiones y transportes antes de hacer operaciones o reparaciones.		
OPERATING INSTRUCTIONS / INSTRUCCIONES DE USO		
FOR TRUCKS HIGHER THAN DOCK: In "AUTO" mode, hold the "RAISE" button to extend the lip, then release it to allow the lip to drop to the trailer. When the trailer tires, the dock drops and it then re-raises to the proper unit. The trailer must be fully up, and the power set to "off". The dock then lowers to the cross-waffle position.		
FOR TRUCKS LOWER THAN DOCK: Set the selector to "MAN" mode. Hold the "RAISE" button to extend the lip, then release it to allow the lip to drop onto the trailer. When the trailer tires and the leveler drops, briefly press the "RESET" button. The unit automatically re-raises itself at the cross-waffle lip supported position. (It's hold the "RAISE" button long enough for the trailer to drop the lip to rest above the "waffle", then release it.)		
PARA CAMIONES MÁS ALTOS QUE EL ANDÉN: En el modo "AUTO", apriete el botón "RAISE" (levantar) para extender el labio, entonces suelte para permitir que el labio descienda en el remolque. Cuando el remolque se apoye, el andén desciende y el transportador de la bodega baja y se eleva a la posición de apoyo. La bodega debe estar completamente elevada y el camión debe estar en posición de apoyo.		
PARA CAMIONES MÁS BAJOS QUE EL ANDÉN: Ponga el selector en modo "MAN". Apriete el botón "RAISE" (levantar) para extender el labio, entonces suelte para permitir que el labio descienda en el remolque. Cuando el remolque se apoye y el nivelador descienda, apriete momentáneamente el botón "RESET" (reseteo). La unidad se eleva automáticamente a la posición de apoyo de la cadena de la bodega. (Es apriete el botón "RAISE" (levantar) por suficiente para que el andén caiga sobre el labio y lo deje sobre las "waffles", entonces lo suelte.)		
VESTIL MANUFACTURING CORP. Phone (260) 665-7586 Fax (260) 665-1339 Website: www.vestil.com		
9623483-1 (11/18)		

LIMITED WARRANTY

Vestil Manufacturing Corporation (“Vestil”) warrants this product to be free of defects in material and workmanship during the warranty period. Our warranty obligation is to provide a replacement for a defective, original part covered by the warranty after we receive a proper request from the Warrantee (you) for warranty service.

Who may request service?

Only a warrantee may request service. You are a warrantee if you purchased the product from Vestil or from an authorized distributor AND Vestil has been fully paid.

Definition of “original part”?

An original part is a part used to make the product as shipped to the Warrantee.

What is a “proper request”?

A request for warranty service is proper if Vestil receives: 1) a photocopy of the Customer Invoice that displays the shipping date; AND 2) a written request for warranty service including your name and phone number. Send requests by one of the following methods:

<u>US Mail</u>	<u>Fax</u>	<u>Email</u>
Vestil Manufacturing Corporation 2999 North Wayne Street, PO Box 507 Angola, IN 46703	(260) 665-1339 <u>Phone</u> (260) 665-7586	info@vestil.com Enter “Warranty service request” in subject field.

In the written request, list the parts believed to be defective and include the address where replacements should be delivered. After Vestil receives your request for warranty service, an authorized representative will contact you to determine whether your claim is covered by the warranty. Before providing warranty service, Vestil will require you to send the entire product, or just the defective part (or parts), to its facility in Angola, IN.

What is covered under the warranty?

The warranty covers defects in the following original, dynamic parts: motors, hydraulic pumps, motor controllers, and cylinders. It also covers defects in original parts that wear under normal usage conditions (“wearing parts”), such as bearings, hoses, wheels, seals, brushes, and batteries.

How long is the warranty period?

The warranty period for original dynamic components is 1 year. For wearing parts, the warranty period is 90 days. Both warranty periods begin on the date Vestil ships the product to the Warrantee. If the product was purchased from an authorized distributor, the periods begin when the distributor ships the product. Vestil may, at its sole discretion, extend a warranty period for products shipped from authorized distributors by up to 30 days to account for shipping time.

If a defective part is covered by the warranty, what will Vestil do to correct the problem?

Vestil will provide an appropriate replacement for any *covered* part. An authorized representative of Vestil will contact you to discuss your claim.

What is not covered by the warranty?

The Warrantee (you) is responsible for paying labor costs and freight costs to return the product to Vestil for warranty service.

Events that automatically void this Limited Warranty.

- Misuse;
- Negligent assembly, installation, operation or repair;
- Installation/use in corrosive environments;
- Inadequate or improper maintenance;
- Damage sustained during shipping;
- Collisions or other accidents that damage the product;
- Unauthorized modifications: Do not modify the product IN ANY WAY without first receiving written authorization from Vestil.

Do any other warranties apply to the product?

Vestil Manufacturing Corp. makes no other express warranties. All implied warranties are disclaimed to the extent allowed by law. Any implied warranty not disclaimed is limited in scope to the terms of this Limited Warranty. Vestil makes no warranty or representation that this product complies with any state or local design, performance, or safety code or standard. Noncompliance with any such code or standard is not a defect in material or workmanship.

