

Assembly Instructions

LEGS 18" HIGH

PARTS LIST			
REFERENCE LETTER	PART NUMBER	DESCRIPTION	QUANTITY
A	SHELF-18X24-KD-B	TOP / LOWER SHELF	2
	SHELF-24X30-KD-B		
	SHELF-24X36-KD-B		
	SHELF-24X48-KD-B		
B	MTKD-LEG-18	LEG	4
C	MT-LEG-10.875	LEG EXTENTION	4
D	H633	BOLT	24
E		NUT	24

MODEL
MTA182424-1.5K295
MTA243024-1.5K295
MTA243624-1.5K295
MTA244824-1.5K295

STEP 1:

Attach 4 legs to top shelf.
Use 2 bolts and nuts for each corner.

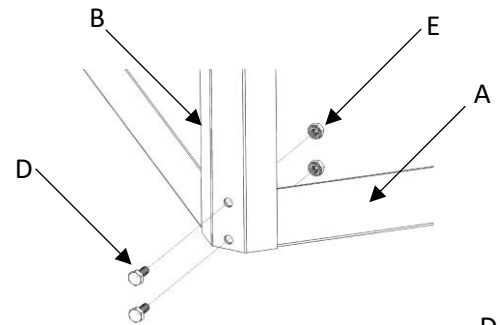
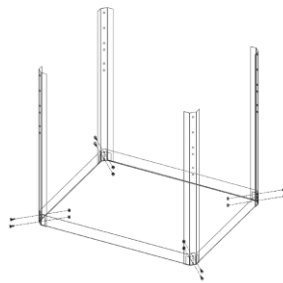

STEP 2:

Attach 4 legs to lower shelf.
Use 1 bolt and nut for each corner.

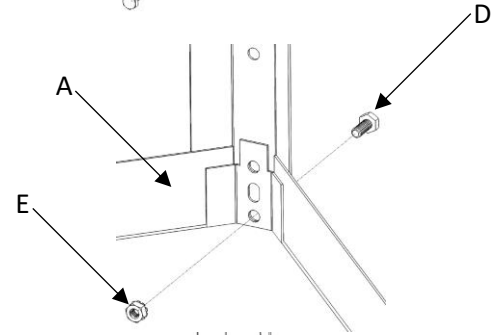
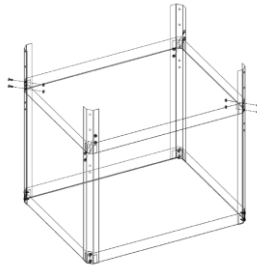

STEP 3:

Attach leg extensions to each leg, setting the position at desired table height.
Use 2 bolts and nuts for each leg extension for maximum strength.

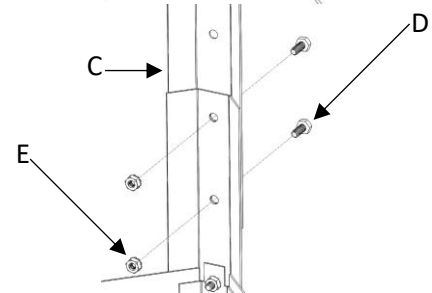
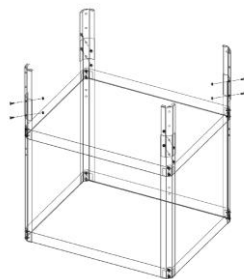

STEP 4:

Check all bolts for tightness.

QUESTIONS, PROBLEMS, MISSING PARTS? Before returning, please contact:

Customer Service, The Durham Manufacturing Company

EMAIL: info@durhammfg.com • WEB: www.durhammfg.com

TEL: 860-349-3427/800-243-3774 • FAX: 860-349-8572/800-782-5499

DURHAM MFG
Est. 1922

DH1162 Rev A

Assembly Instructions

LEGS 18" HIGH

PARTS LIST			
REFERENCE LETTER	PART NUMBER	DESCRIPTION	QUANTITY
A	SHELF-18X24-KD-B	SHELF TOP	1
	SHELF-24X30-KD-B		
	SHELF-24X36-KD-B		
	SHELF-24X48-KD-B		
B	SHELF-18X24-KDH-B	LOWER SHELF	1
	SHELF-24X30-KDH-B		
	SHELF-24X36-KDH-B		
	SHELF-24X48-KDH-B		
C	MTKD-LEG-18	LEG	4
D	MT-LEG-10.875	LEG EXTENTION	4
		BOLT	
E	H634	NUT	36
F		CASTERS	4

MODEL
MTMA182428-1K23PO95
MTMA243028-1K23PO95
MTMA243628-1K23PO95
MTMA244828-1K23PO95

STEP 1:

Attach 4 legs to top shelf.
Use 2 bolts and nuts for each corner.

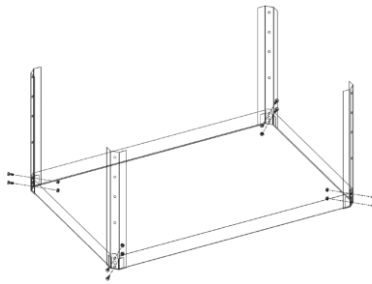

STEP 2:

Attach leg extensions to each leg, setting the position at desired table height. Use 2 bolts and nuts for each leg extension for maximum strength.

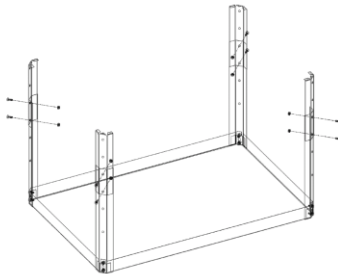

STEP 3:

Attach lower shelf to the end of the leg extensions. Use 1 bolt and nut for each corner.

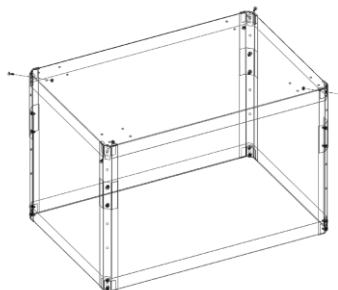

STEP 4:

Attach 4 casters to the lower shelf. Use 4 bolts and nuts for each caster.

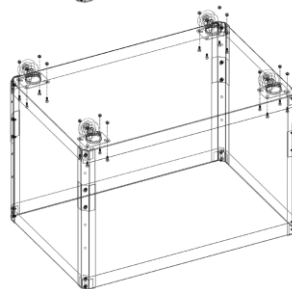

STEP 5:

Check all bolts for tightness.

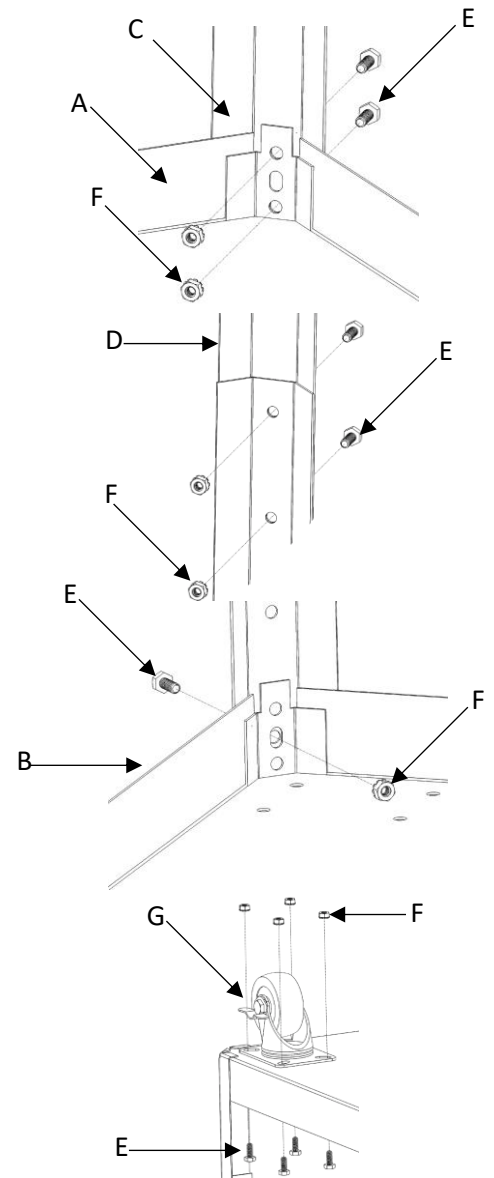

QUESTIONS, PROBLEMS, MISSING PARTS? Before returning, please contact:

Customer Service, The Durham Manufacturing Company
EMAIL: info@durhammfg.com • **WEB:** www.durhammfg.com
TEL: 860-349-3427/800-243-3774 • **FAX:** 860-349-8572/800-782-5499

DURHAM MFG
Est. 1922

DH1162 Rev A

Assembly Instructions

LEGS 30" HIGH

PARTS LIST			
REFERENCE LETTER	PART NUMBER	DESCRIPTION	QUANTITY
A	SHELF-18X24-KD-B SHELF-24X30-KD-B SHELF-24X36-KD-B SHELF-24X48-KD-B	TOP / LOWER SHELF	2
B	MTKD-LEG-30	LEG	4
C	MT-LEG-10.875	LEG EXTENTION	4
D	H633	BOLT	24
E		NUT	24

MODEL
MTA182436-1.5K295
MTA243036-1.5K295
MTA243636-1.5K295
MTA244836-1.5K295

STEP 1:

Attach 4 legs to top shelf.
Use 2 bolts and nuts for each corner.

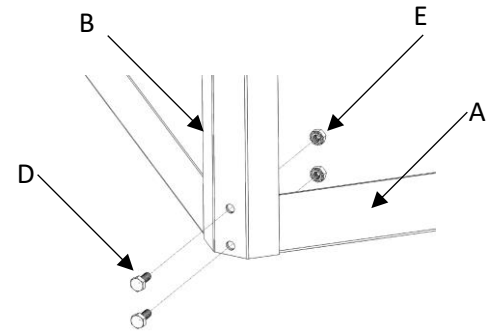
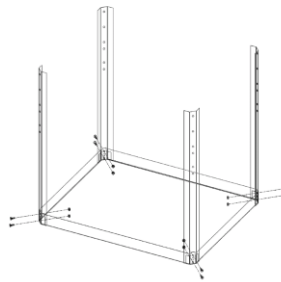

STEP 2:

Attach 4 legs to lower shelf.
Use 2 bolts and nuts for each corner.

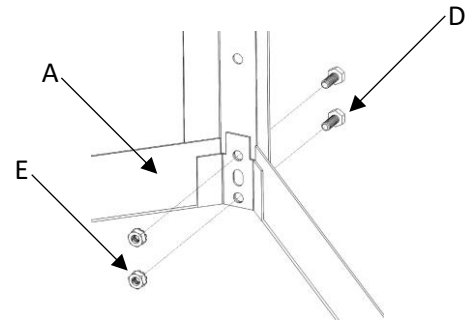
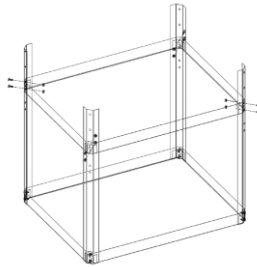

STEP 3:

Attach leg extensions to each leg,
setting the position at desired table
height. Use 2 bolts and nuts for each,
leg extension for maximum strength.

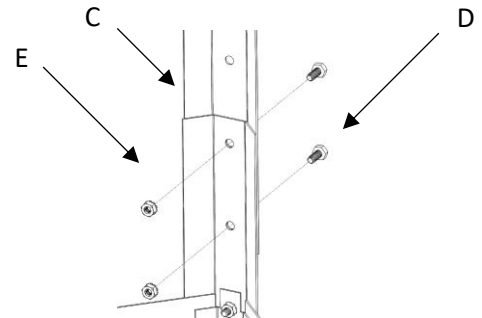
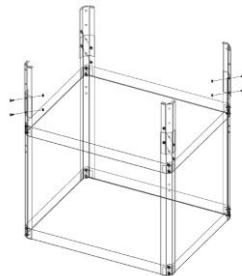

STEP 4:

Check all bolts for tightness.

QUESTIONS, PROBLEMS, MISSING PARTS? Before returning, please contact:

Customer Service, The Durham Manufacturing Company
 EMAIL: info@durhammfg.com • WEB: www.durhammfg.com
 TEL: 860-349-3427/800-243-3774 • FAX: 860-349-8572/800-782-5499

DURHAM MFG
Est. 1922

DH1162 Rev A

Assembly Instructions

LEGS 30" HIGH

PARTS LIST			
REFERENCE LETTER	PART NUMBER	DESCRIPTION	QUANTITY
A	SHELF-18X24-KD-B	SHELF TOP	1
	SHELF-24X30-KD-B		
	SHELF-24X36-KD-B		
	SHELF-24X48-KD-B		
B	SHELF-18X24-KDH-B	LOWER SHELF	1
	SHELF-24X30-KDH-B		
	SHELF-24X36-KDH-B		
	SHELF-24X48-KDH-B		
C	MTKD-LEG-30	LEG	4
D	MT-LEG-10.875	LEG EXTENTION	4
E	H634	BOLT	36
F		NUT	36
G	HC1417S/SB	CASTERS	4

MODEL
MTMA182440-1K23PO95
MTMA243040-1K23PO95
MTMA243640-1K23PO95
MTMA244840-1K23PO95

STEP 1:

Attach 4 legs to top shelf.
Use 2 bolts and nuts for each corner.

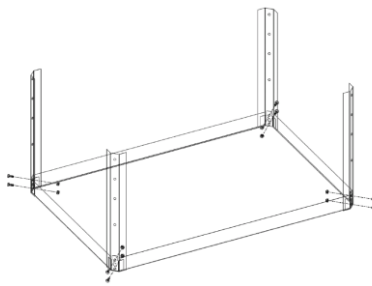

STEP 2:

Attach leg extensions to each leg,
setting the position at desired table
height. Use 2 bolts and nuts for each
leg extension for maximum strength.

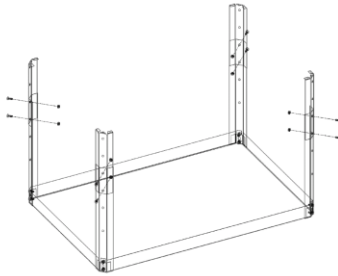

STEP 3:

Attach lower shelf to the end of the
leg extensions.
Use 1 bolt and nut for each corner.

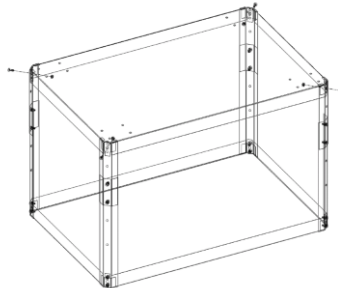

STEP 4:

Attach 4 casters to the lower shelf.
Use 4 bolts and nuts for each caster.

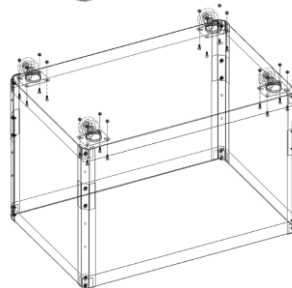

STEP 5:

Check all bolts for tightness.

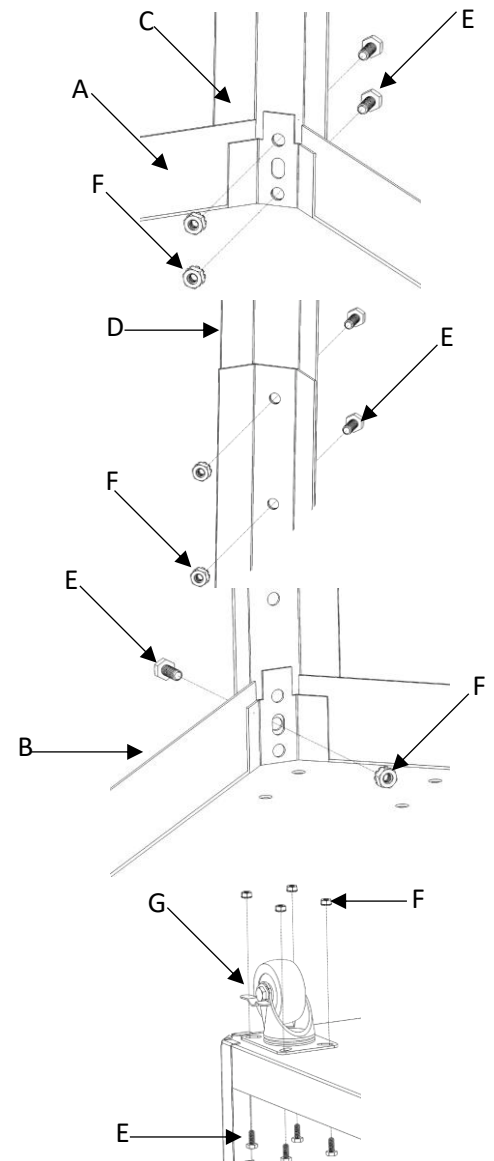

QUESTIONS, PROBLEMS, MISSING PARTS? Before returning, please contact:

Customer Service, The Durham Manufacturing Company
EMAIL: info@durhammfg.com • **WEB:** www.durhammfg.com
TEL: 860-349-3427/800-243-3774 • **FAX:** 860-349-8572/800-782-5499

DURHAM MFG
Est. 1922

DH1162 Rev A