

**Single Wide Unassembled Single Tier
Locker Units With or Without Legs**

RETAIN INSTRUCTIONS FOR FUTURE REFERENCE

.....



GENERAL SAFETY INFORMATION

Some parts may have sharp edges. CARE must be taken when handling various pieces to avoid injury. For safety, wear a pair of work gloves when assembling or performing any maintenance on units.

.....

LIMITED WARRANTY

Tennsco warrants goods purchased hereunder to be free of defects in materials and workmanship for a period of one (1) year from the date of shipment, hereunder. This warranty shall not apply in the event goods are damaged as a result of misuse, abuse, neglect, accident, improper application, modification or repair by persons not authorized by Seller, where goods are damaged during shipment, or where the date stamps on the goods have been defaced, modified or removed. UNLESS CONSIDERED UNENFORCEABLE OR UNLAWFUL UNDER APPLICABLE LAW:

- a. ALL IMPLIED WARRANTIES, INCLUDING BUT NOT LIMITED TO WARRANTIES OR MERCHANTABILITY AND FITNESS FOR A PARTICULAR PURPOSE ARE HEREBY EXCLUDED:
- b. BUYERS REMEDY, IF ANY, FOR ANY DEFECTIVE GOODS SHALL BE LIMITED TO A REFUND BY SELLER OR REPLACEMENT OF THE GOODS AT SELLER'S OPTION, AND SHALL IN NO EVENT INCLUDE DAMAGES OF ANY KIND, WHETHER INCIDENTAL, CONSEQUENTIAL OR OTHERWISE.

NO GOODS ACCEPTED FOR RETURN WITHOUT PRIOR APPROVAL. Seller shall have the right to inspect any goods claimed to be defective at Buyers place of business or require Buyer to return the goods to Seller for inspection on Seller's premises. Transportation charges covering returned goods will be borne by Seller only if such goods are proven to be defective, are covered by this warranty and are returned within the warranty period stated above.

.....



PROUDLY MADE IN THE U.S.A.

Tennsco LLC., Dickson, TN 37056-1888 • (866) 446-8686

ASSEMBLY OF ONE WIDE SINGLE TIER LOCKERS

Tools Needed: A provided 11/32" nut driver (11/32" socket may be substituted).

Two people are recommended for assembly. Approximate assembly time: 40-50 minutes.

1. The reference numbers used throughout this sheet refer to the illustration on the back cover. This is to help you to identify the various parts as they are mentioned.
2. Unpack all the parts then locate the left and right hand sides and separate them. The top of the sides and back can be determined by the three holes closest to the end of the part.
3. Place back (Ref. No. 1) on a protected flat surface so that the flanges face upward. If available, place the unit on a pair of saw horses for easier installation.

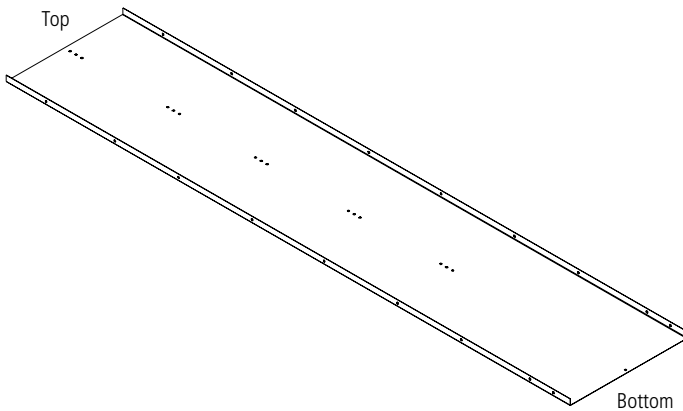

4. Bolt left side (Ref. No. 2) to the back so that the side flange fits around the back.

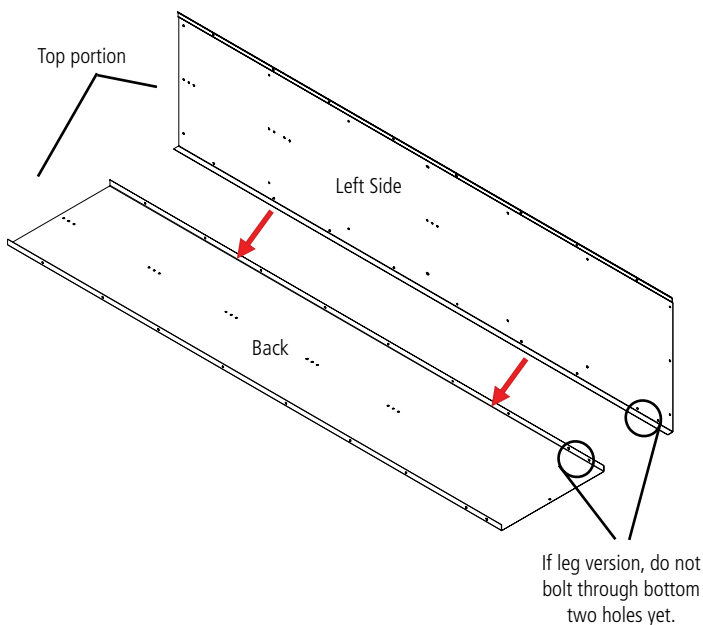

5. Bolt the shelf (Ref. No. 4) to the back and side. Attach the coat hooks (Ref. No. 5) as shown. Attach the top and bottom to the side and back in the same way.

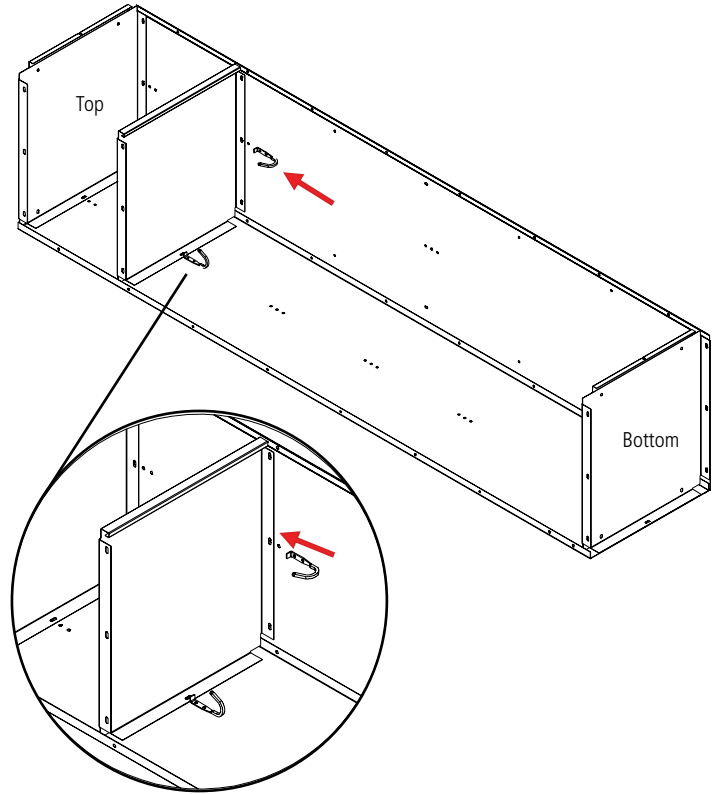

NOTE: For lockers 18" and deeper, bolt the shelf in place and then attach the side coat hook through the third and fourth holes below the shelf.

6. Bolt the right side (Ref. No. 7) to the back so that the side flange fits around the back. Also attach to the top, bottom, and the shelf. Attach the remaining coat hook.

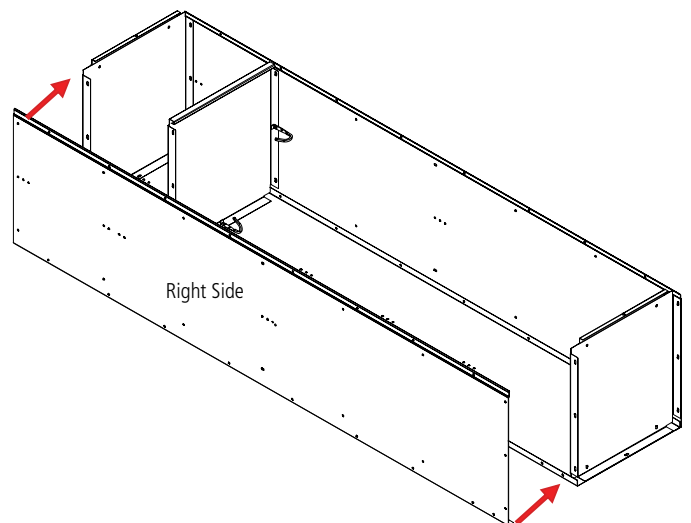

7. If the locker has legs, insert the leg into the corner between the bottom and the side. Bolt the leg to the side using two #8-32 x 1/2 bolts and nuts.

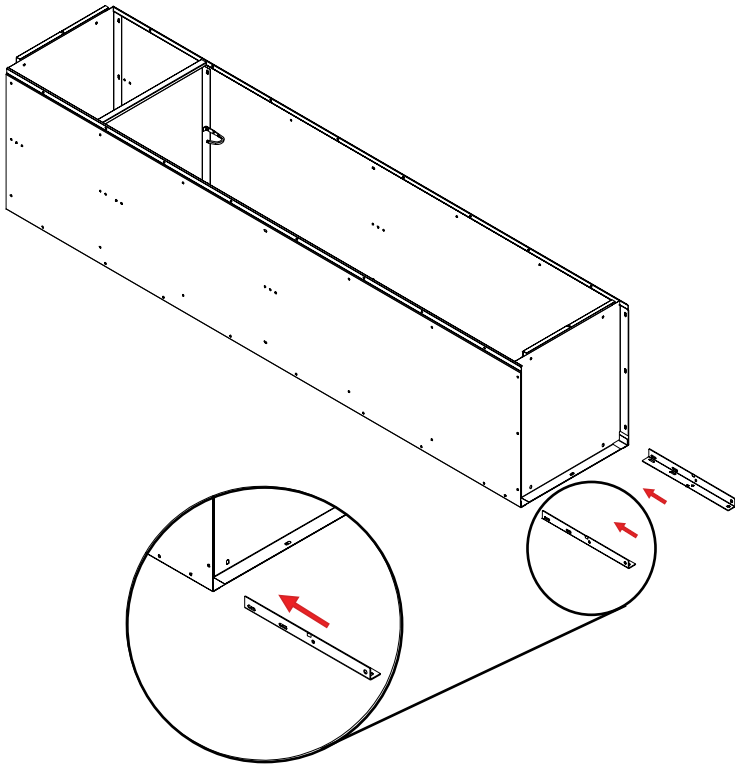

8. Place the door and frame assembly (Ref. Nos. 8 & 9) over the locker body and secure with bolts and nuts. Make certain that body sides are inside frames. If joining units side by side, temporarily install only one bolt and nut in the frame at the end of the unit.

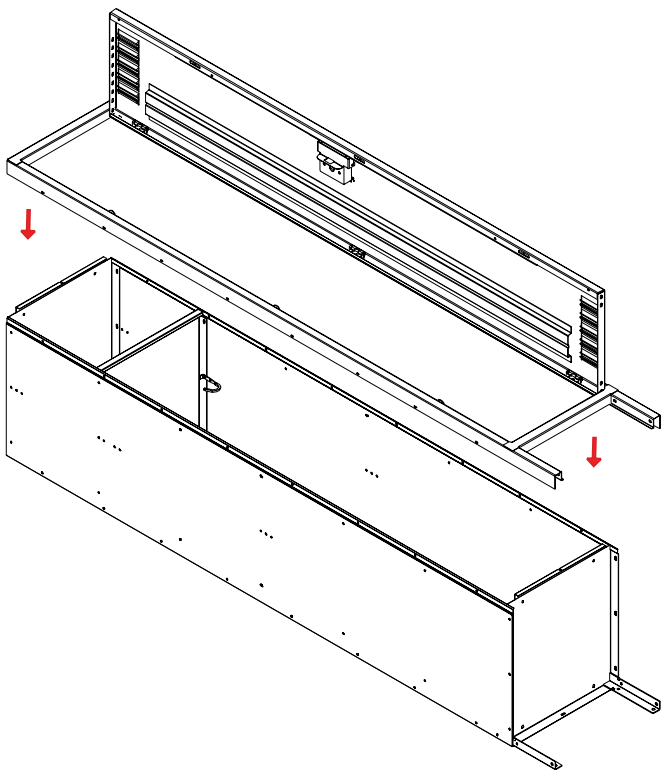

9. Stand the unit upright and place in the desired location. Remove temporary bolts in frames and bolt to adjacent units together through frames.
10. Place the non-slotted end of the coat rod (Ref. No. 10) over the projecting tab at the top of the left coat hook. Slide the slotted end of the coat rod over the projecting tab in the right coat hook and turn 90 degrees to secure it.

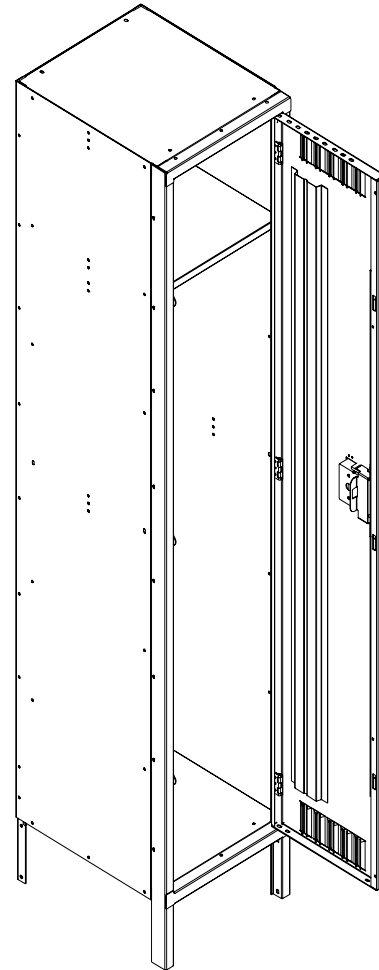

11. Anchor units to wall or floor. The units are not intended to stand free and may topple if not secured. Units standing back to back should be bolted back to back.

NOTE: Care must be taken to assure that lockers are set plumb and level before anchoring.

12. If units are not pre-numbered, optional number plates and plastic covers (Ref. No. 9) may be attached using push plugs (Ref. No. 10). Tennsco name plate (Ref. No. 18) is installed at the factory. As an alternative, custom number or name plates may be ordered from the factory. Your locker is complete.
13. If additional accessories were purchased such as End Bases/ Front Bases (for lockers with legs), Closed Bases (for lockers without legs), Slopping Tops, and/or Combination Locks or Grooved Key Locks, please see the instructions that came along with those parts.

REPLACEMENT PARTS

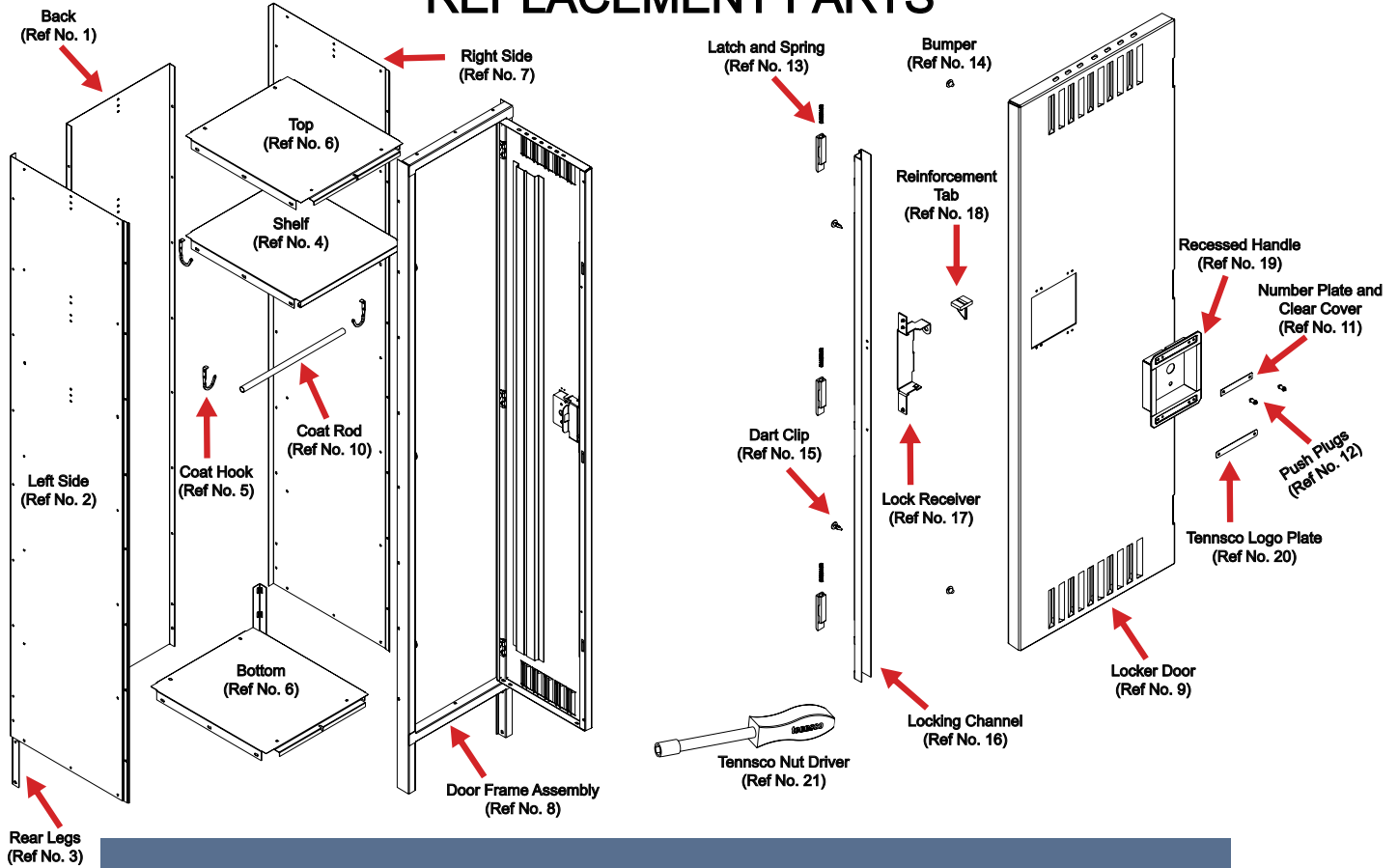

REF. NO.	DESCRIPTION	PART NO.	QTY.
1	Back	LSTB-wwhh	1
2	Left Side	LSSL-ddhh	1
3	Rear Leg (leg version unit only)	LRL-1	2
4	Shelf	ESL-wwdd	1
5	Coat Hook*	LCH-1	3
6	Top/Bottom	LTB-wwdd	2
7	Right Side	LSSR-ddhh-x	1
8	Door Frame Assembly	LSFA-wwhh-x	1
9	Locker Door	LSTD-wwhh	1
10	Coat Rod	LCR-ww	1
11	Paper Number Plate and Clear Cover*	LNP-3CP	1
12	Push Plug*	LPP-1	2
13	Latch and Spring	LL-3	3
14	Bumper	LB-1	2
15	Dart Clip	LDC-1	2
16	Locking Channel	LLCA-1	1
17	Lock Receiver	LPR-2	1
18	Reinforcement Tab	LRT-1	1
19	Recessed Handle - Painted Steel	LRH-2	1
20	Tensco Logo Plate	LPN-2	1
21	Tensco Nut Driver*	TOOL-2	1
22	Bolts and Nuts #8-32 x 1/2" (not shown)*	**	64

*These items are included in the hardware pack enclosed (Part No.: HWSTK1).

** Available Locally

Part No. is composed of prefix shown plus combination of opening or unit. Width = ww and Depth = dd.

Door Frame assemblies require a further suffix (x) of either 1 or A. "1" indicates frame with legs; "A" indicates frame without legs. For example: A door frame assembly for locker STK-151872-1 (with legs) would be Part No. LSFA-1572-1. The door assembly alone without the frame for the same locker would be Part No. LSTD-1572.

NOTE: Additional hardware may be included for replacement purposes.

Tensco makes every effort to ensure that all units ship complete with all parts and arrive undamaged. However, should your unit contain missing or damaged parts, please contact your purchase location.