

User's manual

Manual del usuario

Manuel de l'utilisateur

Customer Service
US: 1-800-645-2986

Servicio de atención al Cliente
US: 1-800-645-2986

Service à la clientèle
Canada: 888-645-2986

Battery Powered Scissor Lift

Model 989062 - Battery Powered Scissor Lift 40" x 20-1/2" Table 660 Lb. Cap.
Model 988854 - Battery Powered Scissor Lift 40" x 20-1/2" Table 1100 Lb. Cap.



Read this manual thoroughly prior to installation, operation or maintenance. Keep these instructions in a safe location for future reference. For questions, visit globalindustrial.com or contact Customer Service at 1-800-645-2986.

Battery Powered Scissor Lift Instruction Manual

READ THIS OPERATION MANUAL COMPLETELY BEFORE USING.
THOROUGHLY UNDERSTAND AND FOLLOW ALL SAFETY INSTRUCTIONS.

1. WARNING

1. DO NOT allow another person to stand in front of or behind lifter when it starts to move.
2. ALWAYS travel with table in lowered position. Load could fall down.
3. NEVER sit, stand or ride on platform. This can lead to SEVERE PERSONAL INJURY.
4. NEVER go under platform. This can lead to SEVERE PERSONAL INJURY or DEATH.
5. DO NOT use in area of multilevel floor surface that could create loss control and result in SEVERE INJURY and PROPERTY DAMAGE.
6. DO NOT use lifter on slope, uneven or soft surface. Lifter may become uncontrollable. This can lead to SEVERE PERSONAL INJURY and PROPERTY DAMAGE.
7. KEEP FEET CLEAR of rolling wheels that could result in SEVERE PERSONAL INJURY.
8. DO NOT load one fork more than the other and DO NOT load tips on table. This can lead to SEVERE PERSONAL INJURY and PROPERTY DAMAGE.
9. DO NOT overload lifter. ALWAYS stay within designated capacity and load center rating. SEVERE PERSONAL INJURY and PROPERTY DAMAGE could result.
10. SHEARING HAZARD. NEVER place hands or feet under lowering table. This could lead to SEVERE PERSONAL INJURY.
11. DO NOT use near fire.
12. HIGH VOLTAGE. Disconnect battery socket before opening control panel box.
13. DO NOT remove battery terminal cover. Short-circuit or electric shock could occur.

2. CAUTION

1. Hazard or unsafe practice, which, if not avoided, may result in PERSONAL INJURY and PROPERTY DAMAGE.
2. READ THE OPERATION MANUAL COMPLETELY BEFORE USING AND THOROUGHLY UNDERSTAND AND FOLLOW ALL SAFETY INSTRUCTIONS.
3. This lifter is designed for use with stable uniform load on a solid level floor. DO NOT use the lifter for any other purpose than its intended use.
4. Only TRAINED personnel shall operate lifter. OPERATORS shall read this manual completely and thoroughly understand the controls and operation of this equipment BEFORE operating the lifter.
5. ALWAYS observe lifter and ALWAYS stay at the controls while the lifter is in motion. RELEASE controls and STOP lifter immediately if load on lifter appears to become unstable. NEVER leave the loaded lifter unattended unless the table is in the fully lowered position and the lifter is locked.
6. DO NOT slide the load on or off the table. The lift may move allowing the load to fall. SEVERE PERSONAL INJURY and PROPERTY DAMAGE could result.
7. DO NOT use lifter with unstable, unbalanced or loosely stacked load. Unbalanced loads may become unstable and fall. This can cause SEVERE PERSONAL INJURY and PROPERTY DAMAGE
8. Qualified personnel must perform ALL lifter service only.
9. ALWAYS keep feet, hands and fingers away from casters, load wheels and all moving components.
10. ALWAYS perform maintenance and inspections with lifter unloaded.
11. Prolonged continuous working might cause damage of power pack.
12. Stop operation if temperature of hydraulic oil is too high.
The lifter is NOT waterproof and is intended to be used in a dry environment.

3. DAILY INSPECTION

Daily inspection is effective to find the malfunction or faulty on the lifter. Check the lifter on the following points before the operation.

CAUTION

DO NOT use lifter if any malfunctions are found.
--

- (1) Check for scratches, deformations, or cracks on the lifter.
- (2) Ensure wheels move smoothly.
- (3) Check if there is oil leakage.
- (4) Check for vertical creep of the table.
- (5) Check the brakes.
- (6) Check if all the bolts and nuts are tightened firmly.

Battery Powered Scissor Lift

4. NAME OF PARTS

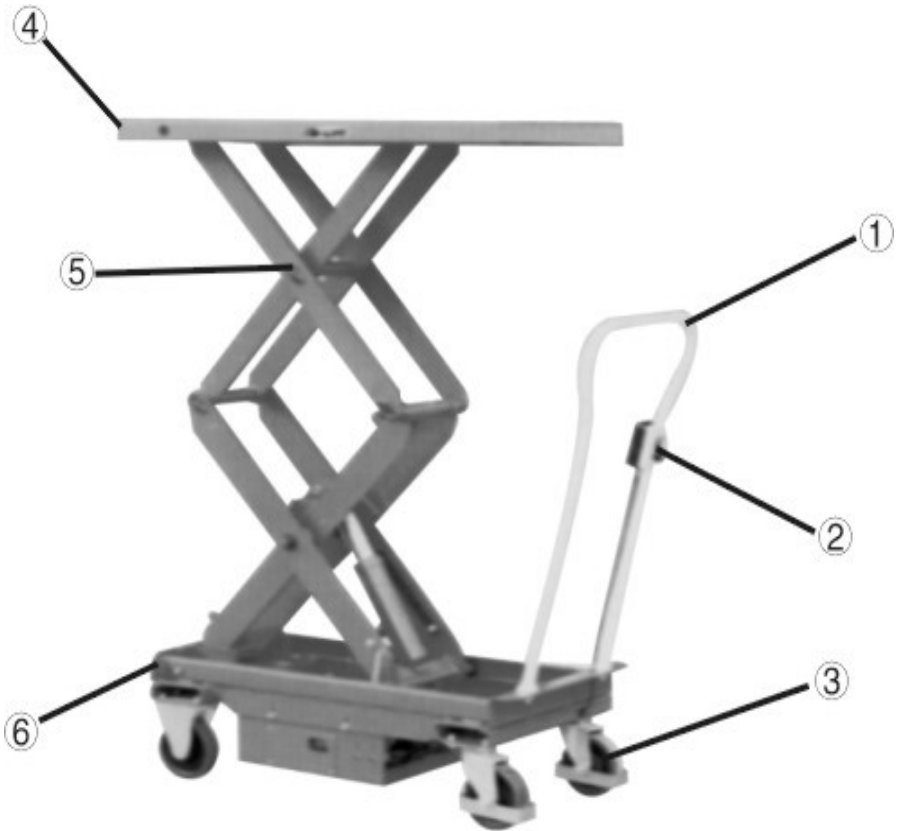

1.Handle

2.Switch

3.Brake Pedal

4.Platform

5.Link

6.Guide rail

Battery Powered Scissor Lift

5. OPERATING LIFT TABLE

How to use the brake.

CAUTION

Use brakes when not moving the lifter to prevent sudden movement.

The brake is equipped with the swivel caster on the right side.

- (1) Activate wheel brakes by pressing the brake pedal.
- (2) Release the brake by lifting up the brake pedal.

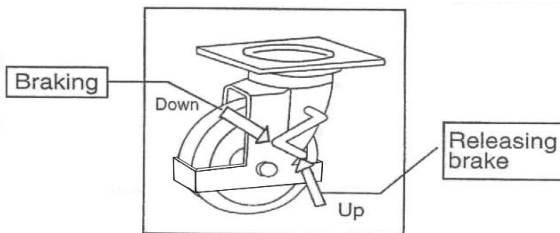

6. LIFTING UP FORKS

CAUTION

1. DO NOT overload lifter. Stay within its rated capacity.
2. Prolonged continuous working might cause damage of hydraulic power pack.
3. Stop operation if temperature of hydraulic oil is too high.

Push the button "UP" and the table lifts up.

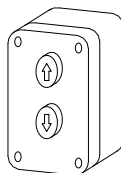
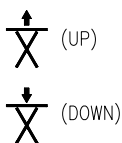

M AU —TYPE 0.7kW(NOMINAL)12V.D.C

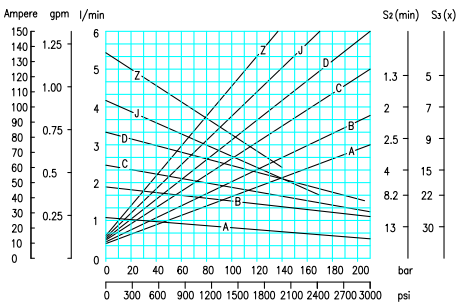

TYPE OF PUMP

A	GR.0.5 - 0.25	D	GR.0.5 - 0.75
B	GR.0.5 - 0.45	J	GR.0.5 - 0.92
C	GR.0.5 - 0.56	Z	GR.0.5 - 1.26

— Curve S2 defines the maximum running time of the D.C. Motor expressed in a minutes.

— Curve S3 expresses the on-off ratio in % which has value S3 in a total work cycle (100%).

Battery Powered Scissor Lift

7.LOWERING TABLE

CAUTION

DO NOT lower table with load too fast and stop suddenly. Impact load could be created and lifter could be damaged.

8.MOVING THE LIFTER

WARNING

DO NOT move lifter on slope or inclined surface, otherwise lifter becomes uncontrollable and dangerous

- (1) Make the load stable to prevent it from falling.
- (2) Lower the table down.
- (3) Release the brake and move the lifter.

CAUTION

KEEP watching the condition of load. Stop operating lifter if load becomes unstable.

9.CHARGING THE BATTERY

- (1) Check the quantity of Battery fluid. If it is insufficient, add the battery solution according to battery operation manual.
- (2) Disconnect the battery socket.
- (3) Connect the charging port of battery socket to the battery charger.

10.REGULAR INSPECTION

Perform the regular inspection for the safety operation.

- (1) Check the items expressed in daily inspection (daily).
- (2) Lubricate with grease the guides where roller moves. Also, lubricate the grease nipples.(Every month)
- (3) Lubricate all the pivoting points and axles. (Every 6 months)
- (4) Replace the hydraulic oil for the first time: Accumulated working ten hours'
- (5) Replace the hydraulic oil. (Every 12 months)

11.TROUBLE SHOOTING

PROBLEMS	POSSIBLE CAUSES	POSSIBLE SOLUTIONS
Platform does not rise while motor does not run.	1.Faulty wiring.	1.Check the wiring referring to the actual wiring diagram.
	2.Battery socket is disconnected	2.Connect the battery socket.
	3.Battery charge is insufficient.	3.Charge the battery.
Platform does not rise while motor runs.	1.Faulty adjustment of relief valve.	1.Adjust relief valve again.
	2.Faulty hydraulic pump.	2.Replace power pack.
	3.Shortage of hydraulic oil.	3.Add oil.
Vertical creep of table.	1.Oil leakage in power pack.	1.Replace lowering valve.
	2.Oil leakage form hydraulic circuit.	2.Check hydraulic circuit and repair.
Oil leakage from cylinder.	Faulty sealing.	Replace sealing.
Oil leakage from piping or joint.	Insufficient tightening or seal in valid.	Tighten joint again or Replace seal.
Oil leakage from air breather.	Excessive quantity of oil.	Reduce oil quantity.

Battery Powered Scissor Lift

12. SPECIFICATIONS

Model	989062	988854
Capacity (lbs)	660	1100
Table (inches)	40 x 20.5	40 x 20.5
Min. table height (inches)	19.5	19.5
Max. Table height (inches)	63	63.7
Lifting stroke (inches)	43.5	44.2
Motor (KW)	0.7	0.7
Work cycle of hydraulic power pack	3 times of table moving up-down per 10 min.	
Approx. numbers of lifting at full charge and with full load (times)	45	40
Approx. time required lifting up table. (Sec)	15	15
Wheel (inches, diameter)	.23	.23
Handle height (inches)	46.5	46.5
Weight (lbs)	403.4	403.4

13. HYDRAULIC CIRCUIT/WIRING DIAGRAM/ACTUAL WIRING DIAGRAM

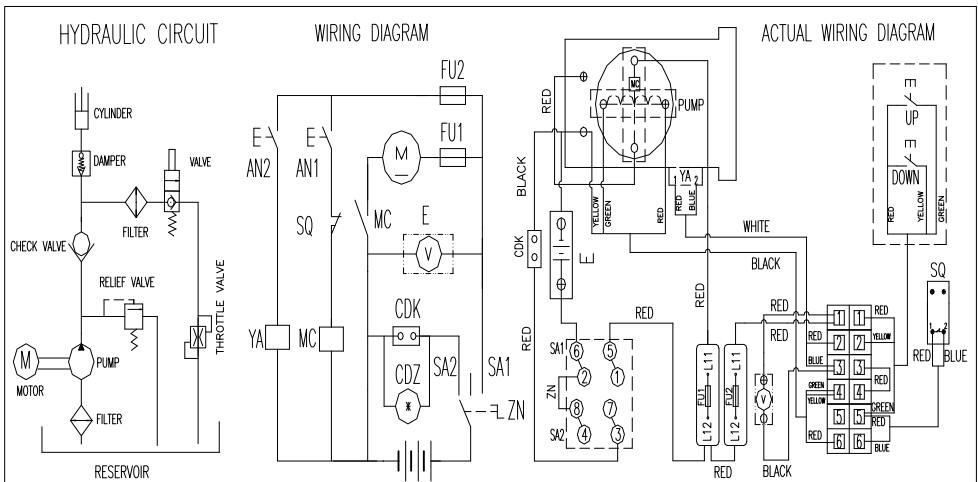

Battery Powered Scissor Lift

989062

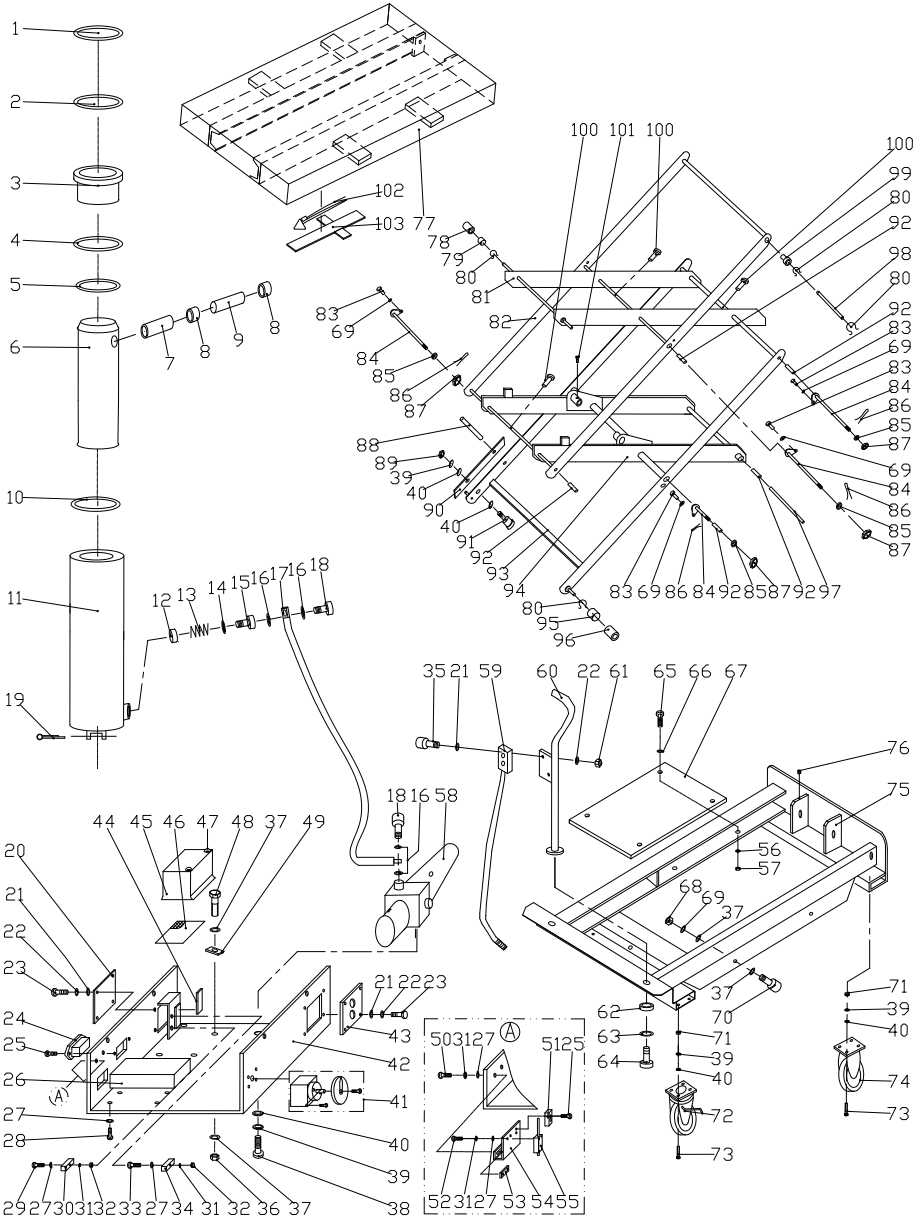

LIFT TABLE SPARE PARTS LIST 989062

NO	DESCRIPTION	QTY	NO	DESCRIPTION	QTY
1	Seal cover $\phi 50 \times \phi 58 \times 6.5$	1	26	Charger	1
2	Y-ring $\phi 50 \times \phi 58 \times 8.2$	1	27	Washer 5	10
3	Cylinder cover	1	28	Screw M5 \times 10	4
4	Retainer ring	1	29	Screw M5 \times 20	1
5	O-ring $\phi 56 \times 2.65$	1	30	Fuse	1
6	Piston rod	1	31	Spring washer 5	6
7	Bushing	1	32	Nut M5	2
8	Bushing	2	33	Screw M5 \times 16	1
9	Pin axle	1	34	Fuse	1
10	Snap ring 50	1	35	Screw M4 \times 16	2
11	Cylinder	1	36	Nut M8	4
12	Prevent burst valve	1	37	Washer 8	16
13	Spring	1	38	Screw M10 \times 16	2
14	Seal ring 18	1	39	Spring washer 10	20
15	Prevent burst joint	1	40	Washer 10	22
16	Seal ring 14	4	41	Switch	1
17	High pressure hose	1	42	Battery case weldment	1
18	Joint	2	43	Covering plate	1
19	Split Pin	1	44	Pad	1
20	Covering plate	1	45	Battery	1
21	Washer 4	10	46	Insulator pad	1
22	Spring washer 4	10	47	Insulation case	2
23	Screw M4 \times 10	8	48	Screw M8 \times 40	4
24	Battery indicator	1	49	Battery securing tag	4
25	Screw M3 \times 10	4	50	Screw M5 \times 16	2

Battery Powered Scissor Lift

51	Connector block	1	78	Roller for table	2
52	Screw M5×10	2	79	Bushing	2
53	Fixing plate	1	80	Retaining ring for axle 20	6
54	Joint board	1	81	Internal scissors for table	1
55	Lifting limit switch	1	82	External scissors for table	1
56	Spring washer 6	4	83	Screw M8×16	5
57	Nut M6	4	84	Pin axle for scissors	4
58	Hydraulic power pack	1	85	Washer	4
59	Terminals	1	86	Split pin 3.2×26	4
60	Handle	1	87	Nut M16×1.5	4
61	Nut M4	2	88	Spring pin 8×30	2
62	Washer	2	89	Nut M10	2
63	Spring washer 12	2	90	Safety rod	2
64	Hex screw M12×30	2	91	Screw M10×40	2
65	Hex screw M6×20	4	92	Bushing	10
66	Washer 6	4	93	External scissors for chassis	1
67	Covering plate	1	94	Internal scissors for chassis	1
68	Nut M8	4	95	Bushing	2
69	Spring washer 8	8	96	Roller for chassis	2
70	Screw M8×20	4	97	Pin axle for chassis	1
71	Nut M10	16	98	Pin axle for table	1
72	Rear wheel	2	99	Bushing	2
73	Screw M10×25	16	100	Oil cup	5
74	Front wheel	2	101	Screw M6×16	2
75	Chassis	1	102	Cable	1
76	Screw M6×8	1	103	Cable velcro strap	1
77	Table	1			

Battery Powered Scissor Lift

988854

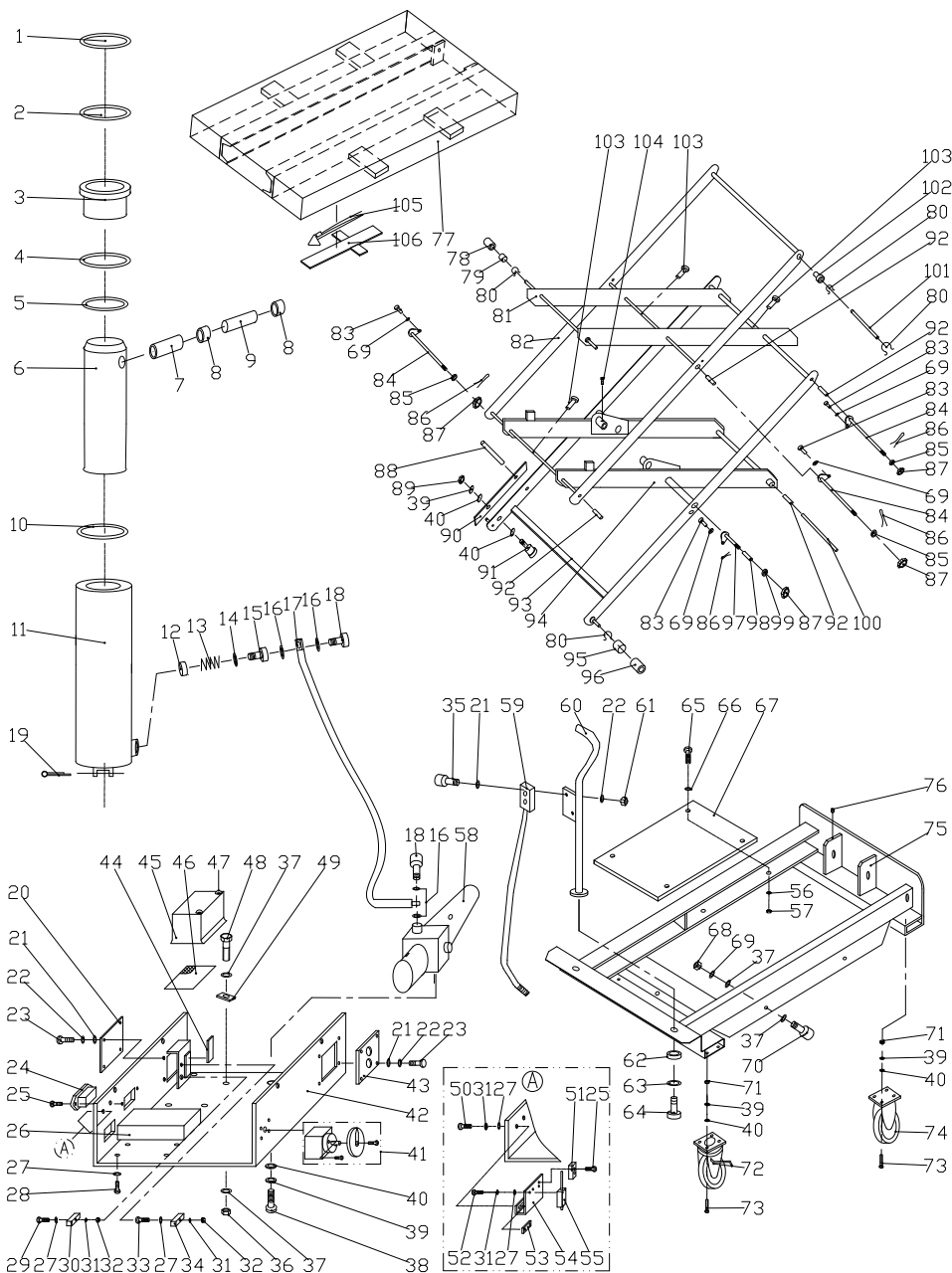

LIFT TABLE SPARE PARTS LIST 988854

NO	DESCRIPTION	QTY	NO	DESCRIPTION	QTY
1	Seal cover $\phi 60 \times \phi 68 \times 6.5$	1	26	Charger	1
2	Y-ring $\phi 60 \times \phi 70 \times 6$	1	27	Washer 5	10
3	Cylinder cover	1	28	Screw M5 \times 10	4
4	Retainer ring	1	29	Screw M5 \times 20	1
5	O-ring $\phi 65 \times 2.65$	1	30	Fuse	1
6	Piston rod	1	31	Spring washer 5	6
7	Bushing	1	32	Nut M5	2
8	Bushing	2	33	Screw M5 \times 16	1
9	Pin axle	1	34	Fuse	1
10	Snap ring 60	1	35	Screw M4 \times 16	2
11	Cylinder	1	36	Nut M8	4
12	Prevent burst valve	1	37	Washer 8	16
13	Spring	1	38	Screw M10 \times 16	2
14	Seal ring 18	1	39	Spring washer 10	20
15	Prevent burst joint	1	40	Washer 10	22
16	Seal ring 14	4	41	Switch	1
17	High pressure hose	1	42	Battery case weldment	1
18	Joint	2	43	Covering plate	1
19	Split Pin	1	44	Pad	1
20	Covering plate	1	45	Battery	1
21	Washer 4	10	46	Insulator pad	1
22	Spring washer 4	10	47	Insulation case	2
23	Screw M4 \times 10	8	48	Screw M8 \times 40	4
24	Battery indicator	1	49	Battery securing tag	4
25	Screw M3 \times 10	4	50	Screw M5 \times 16	2

Battery Powered Scissor Lift

51	Connector block	1	79	Bushing	2
52	Screw M5×10	2	80	Retaining ring for axle 20	6
53	Fixing plate	1	81	Internal scissors for table	1
54	Joint board	1	82	External scissors for table	1
55	Lifting limit switch	1	83	Screw M8×16	5
56	Spring washer 6	4	84	Pin axle for scissors	3
57	Nut M6	4	85	Washer	3
58	Hydraulic power pack	1	86	Split pin 3.2×26	5
59	Terminals	1	87	Nut M16×1.5	5
60	Handle	1	88	Spring pin 8×30	2
61	Nut M4	2	89	Nut M10	2
62	Washer	2	90	Safety rod	2
63	Spring washer 12	2	91	Screw M10×40	2
64	Hex screw M12×30	2	92	Bushing	8
65	Hex screw M6×20	4	93	External scissors for chassis	1
66	Washer 6	4	94	Internal scissors for chassis	1
67	Covering plate	1	95	Bushing	2
68	Nut M8	4	96	Roller for chassis	2
69	Spring washer 8	9	97	Pin axle	2
70	Screw M8×20	4	98	Bushing	2
71	Nut M10	16	99	Washing	2
72	Rear wheel	2	100	Pin axle for chassis	1
73	Screw M10×25	16	101	Pin axle for table	1
74	Front wheel	2	102	Bushing	2
75	Chassis	1	103	Oil cup	4
76	Screw M6x8	1	104	Screw M6×16	2
77	Table	1	105	Cable	1
78	Roller for table	2	106	Cable velcro strap	1

OPERATION INSTRUCTION ENERGY SERVICE-FREE ACID-LEAD STORAGE BATTERY

1. Storage and Transportation

- ◇ Uncharged ENERGY storage battery needs no maintenance, Please store it in dry and frost-free place.
- ◇ If the density of electrolyte in filled battery is less than 1.23kg/l, it shall be recharged as soon as possible, If the density of electrolyte filled in is 1.23kg/l,the storage battery shall be recharged when it is below1.18kg/l.
- ◇ During transportation or storage, the filled storage battery shall be kept upright vertically to prevent acid liquid from overflowing.

2. PUT INTO USE

- ◇ Precharged but unfilled ENERGY storage battery can be put into use at once without charging after electrolyte is filled in it.
- ◇ When it is being filled, the temperature of battery and electrolyte should be 10°C at least.
- ◇ Each unit of battery shall be filled with special acid whose density is 1.28kg/l. (1.23kg/l in the area of tropics),and be filled up to the line indicating the maximum level or to the height of 15mm over the top of pole plate.
- ◇ Let the battery sit for about 15 minutes, Then sway the battery gently several times. Refill proper electrolyte if necessary.
- ◇ Screw or press the sealing hole tightly.
- ◇ Clean the acid liquid left on its surface.
- ◇ The storage battery can be in good condition without any service within 5 years at the temperature of 20°C.

3. CHARGING

- ◇ Before recharging, please take the battery down.
- ◇ The storage battery is allowed to be charged with DC power. Connect the plus pole and minus pole of storage battery correspondingly to the poles of the charger.
- ◇ Ensure to connect the poles correctly then switch on the charger.
- ◇ When the battery is charged, remove the charger.
- ◇ Recommended charging current is 1/10 of battery capacity (e.g. $1/10 \times 44 = 4.4A$ for the storage battery with capacity of 44 Ah.)
In the course of charging, the temperature of electrolyte is not allowed to be above 55°C.
- ◇ If the temperature of electrolyte is above 55°C, stop charging.
- ◇ If the density of electrolyte and the voltage of the battery stop increasing for 2 hours, the storage battery could be fully charged.
- ◇ When the charging is ended, please check the level of electrolyte, Add pure water to the maximum level indicating line if necessary.

4. Maintenance

To ensure the service life of storage battery, the following points must be followed.

- ◇ Keep battery surface clean and dry, When cleaning, only wet cloth can be used, Make sure that the liquid level is in specified position and add pure water if necessary.
- ◇ Charge status can be checked by electrolyte density test.
- ◇ If the density of electrolyte is below 1.23kg/l(1.18kg/l in the area of tropic), the storage battery must be recharged.
- ◇ At such density, freezing point of electrolyte is -15°C (at the density of 1.28kg/l. freezing point is -70°C)

WARNING AND SAFETY

- ◇ Follow instructions described on the plate of the battery.
- ◇ Wear safety glasses.
- ◇ Keep children away from touching electrolyte and battery.
- ◇ Explosive Hazard Easy-explosive mixture come to escape during charge, So fire electric spark, uncovered bulb and fireworks are strictly inhibited, When connecting wire-circuit, electric spark and short-circuit must be avoided.
- ◇ Hazard of strong corrosion Electrolyte is strongly corrosive, So please wear protective clothes and safety glasses, Do not tilt the storage battery otherwise acid liquid will overflow.
- ◇ Emergency Cure when the acid liquid spatters in the eyes, wash it with a large quantity of clean water at once, then see a doctor, Acid liquid on skin and clothes shall be washed with a large quantity of clean water as well, If acid liquid is swallowed, please see a doctor at once.
- ◇ Warning:
 - Do not put the unprotected storage battery in the sun.
 - Store batteries in a dry and frost-free environment.

- ◇ Handling:
 - Follow rules of transportation(GGVS)during transporting.
 - Do not mix discarded battery with daily rubbish.