

# MAGNUM

## Model 1300 TB-U Uniform Top and Bottom Drive Case Sealer

The Magnum 1300 TB-U utilizes dual top and bottom belt drives that provide the best performance for cases that are overstuffed or tall and unstable, where side belt drive systems are less suitable. The machine can be adjusted quickly for different box sizes using a crank handle and two locking knobs.

Highlight's case sealers are equipped with Magnum 200 Series tape heads which provide accurate and consistent tape application to the top and bottom of cases using any 2" carton sealing tape. Magnum tape heads are engineered with the most heavy duty and reliable components in the industry, and are packed with features for flexibility.

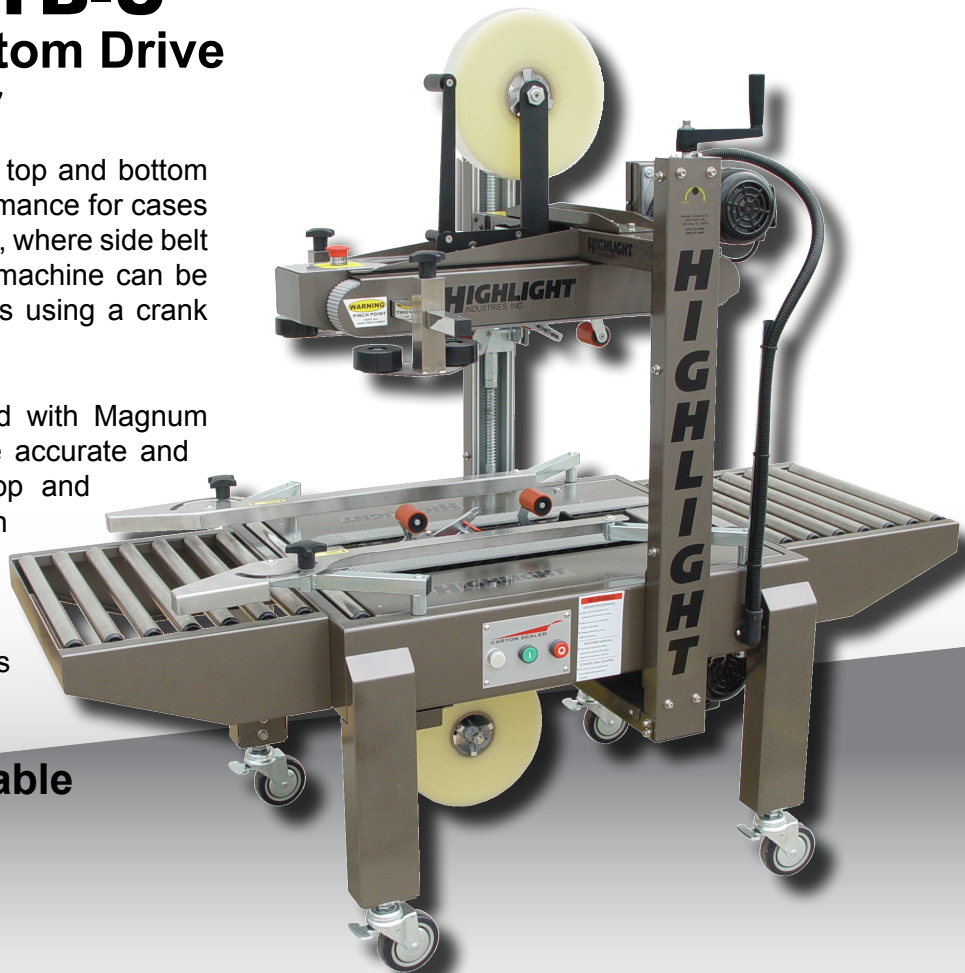

**For simple and reliable  
case sealing!**



## HIGHLIGHTS

- » Top and bottom belt drives provide extra closing force on overstuffed cartons and better handling for unstable cases
- » Magnum tape heads are engineered for performance and packed with features to provide the most reliable tape head in the industry
- » Designed to operate at up to 30 cases per minute for increased productivity

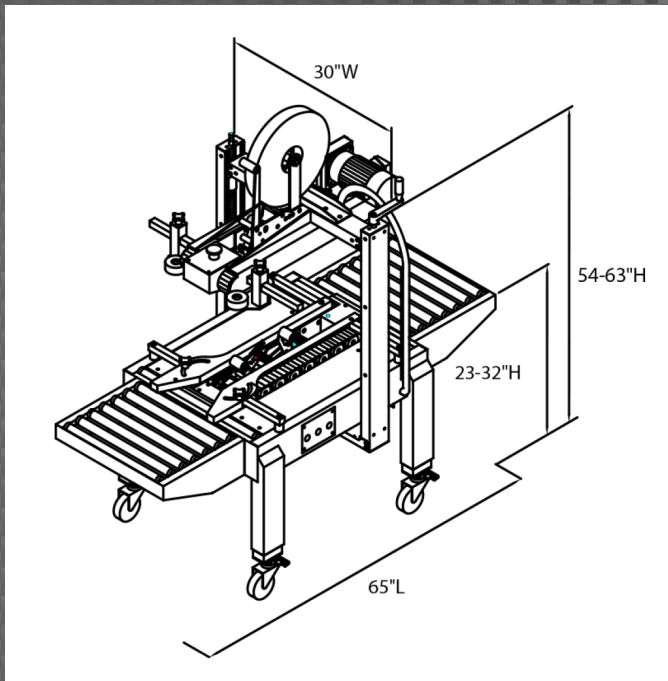

## Roller Conveyors

The Magnum 1300 TB-U comes with 16 inch long entry and exit conveyors with chromed steel rollers and smooth running precision bearings for easy case movement and long life.

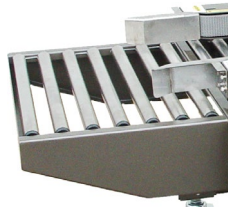

## Locking Swivel Casters

Highlight's heavy duty locking casters allow the Magnum 1300 TB-U to be easily moved around a facility to a work area, or moved aside when not in use.



## Tape Head

The Magnum 1300 TB-U is equipped with a pair of Magnum 200 Series tape heads which are loaded with features to give you the most reliable and flexible tape heads in the industry.



## SIMPLE CONTROLS



- Start Button
- Stop Button
- Centrally Located Emergency Stop
- Power Indicator Light
- Crank Handles and Locking Knobs to adjust height and width

## Top Guide Squeezer Rollers

The included squeezer rollers ensure the top flaps of the case are fully closed to provide a good sealing surface and keep the contents secure.

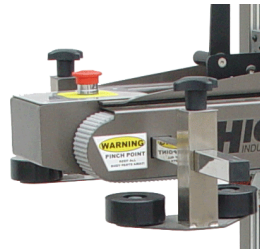

## Heavy Duty

All-steel construction, sturdy design, and powder-coated surfaces make the Magnum 1300 TB-U durable and reliable for years of industrial use.

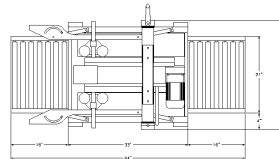

## SYSTEM SPECIFICATIONS

Classification	Top and Bottom Belt Drive Uniform	Machine Dimensions	65" L, 30" W, 58" H
Machine Operating Rate	Up to 30 Boxes per Minute	Case Size Capacity	6" to 20" Wide, 5" to 20" Tall, 5" to Unlimited Length
Belt Speed	75 Feet per Minute	Roller Conveyor Length	16" Entry and Exit
Tape Heads	Highlight's Model 200 Series 2" Tape Heads Standard, 3" Optional	Machine Weight	375 Pounds
Working Height	Adjustable 23" to 32"	Electrical Requirements	110 V, 60Hz, 8 Amp

Contact: