

BULMAN Products, Inc.

1650 McReynolds Avenue, NW
 Grand Rapids, Michigan 49504-2091
 616/363-4416, 616/363-4417 Fax: 616/363-0380
 www.bulmanproducts.com

DELUXE RAZOR-X HEAD ASSEMBLY #69500
 GUARD #6956
 KNIFE #69510

A697 DELUXE RAZOR-X CUTTER WITH HOLD DOWNS

INSTRUCTIONS

1. FASTEN THE BASE TO A TABLE USING THE 4 HOLES IN THE BASE.
2. SLIDE THE ROTARY SHEAR HEAD TO ONE SIDE OF THE ALUMINUM TRACK.
3. FEED MATERIAL UNDER 1 TO 3 HOLD DOWNS.
4. FEED MATERIAL BETWEEN THE TOP OF THE ALUMINUM TRACK & BELOW THE GUIDE TUBE TO YOUR DESIRED LENGTH.
5. SLIDE ROTARY SHEAR HEAD TO OTHER SIDE TO CUT MATERIAL.

DELUXE RAZOR-X CUTTER ASSEMBLY

PART NO.	SIZE
696241	24
696361	36
696481	48
696601	60

GUIDE TUBES	SIZE	PART NO.
	24	691244
	36	691364
	48	691484
	60	691604

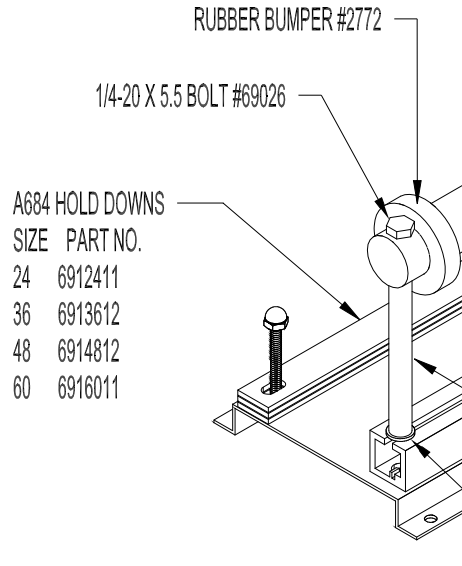

TRACK & TUBE SPACER #690210

A684 BASE	SIZE	PART NO.
	24	694242
	36	694362
	48	694482
	60	694602

© 1997 BULMAN PRODUCTS, INC. 161110/0100

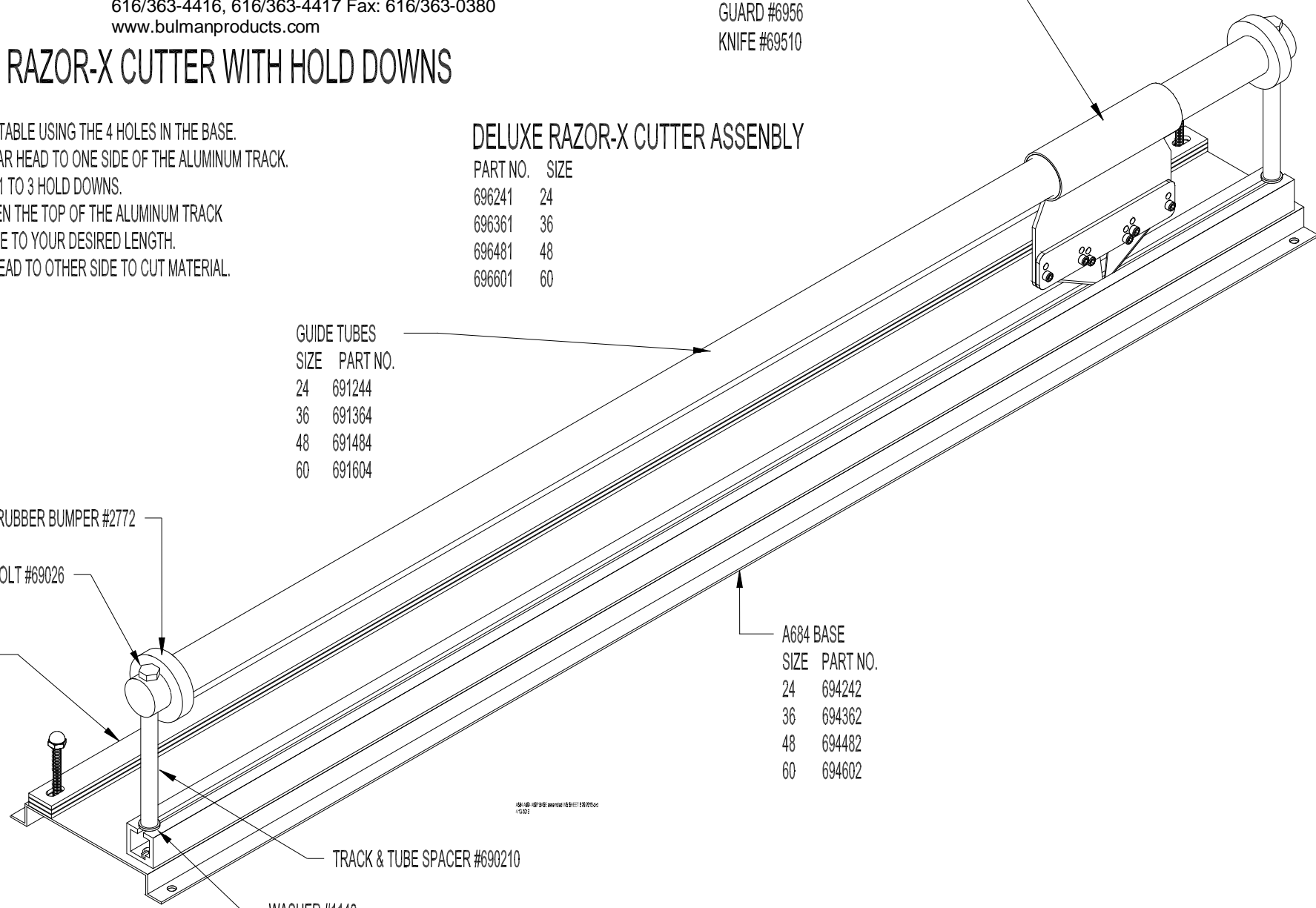

1650 MCREYNOLDS NW. GRAND RAPIDS, MICHIGAN 49504
 PHONE (616) 363-4416 FAX (616) 363-0380

DELUXE RAZOR-X HEAD REPLACEMENT

1. DISASSEMBLE ONE END OF THE CUTTER TO REMOVE THE OLD CUTTING HEAD.
2. ADJUST GUARD HEIGHT FOR MATERIAL THICKNESS.
3. REPLACE CUTTING HEAD AND REASSEMBLE CUTTER.
 MAKE SURE BLADES FIT BETWEEN HARDENED BLUE STEEL BLADE AND ALUMINUM TRACK AND DOESN'T RIDE ON FOAM. SEE DRAWING.

FOR ILLUSTRATION PURPOSES
 SOME FEATURES ARE NOT SHOWN.

THE BEARINGS ARE GLUED IN PLACE.
 THE BEARINGS ARE NOT SERVICEABLE.

DESCRIPTION	PART NO.
DELUXE RAZOR-X HEAD ASSEMBLY COMPLETE	#69500
DELUXE RAZOR-X HEAD TOP ASSEMBLY WITH BEARINGS	#6950
DELUXE RAZOR-X ADJUSTABLE GUARD	#6956
6-32 SCREWS (6-REQ'D)	#69511
UTILITY BLADE (2-REQ'D)	#69510

A690R, A691R, A694, A695, A696 & A697 FOAM & BLADE ASSEMBLY SIZES	PART NOS.
24"	364244
36"	364255
48"	364266
60"	364261
A692 FOAM & BLADE ASSEMBLY	364266

