



www.globalindustrial.com





1-800-645-2986

INDUSTRIAL WORKBENCH

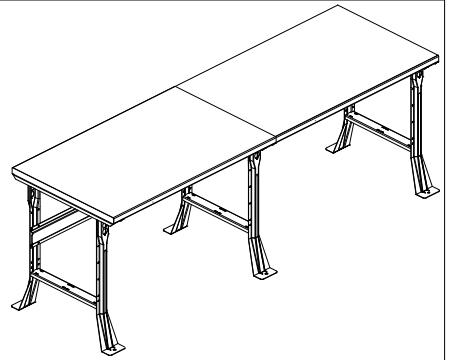
ASSEMBLY INSTRUCTION

FLARED LEG MOD. # 500360



CONTENTS		
REF.	QTY.	DESCRIPTION
1	3	LEG
2	2	STRINGER
3	2	TOP
H1	12	M6 NYLON LOCK NUT 
H2	12	M6 x .625 PHILLIPS PAN HEAD SCREW 
H3	18	10mm hex washer head screw 
	1	7/32 DRILL BIT 

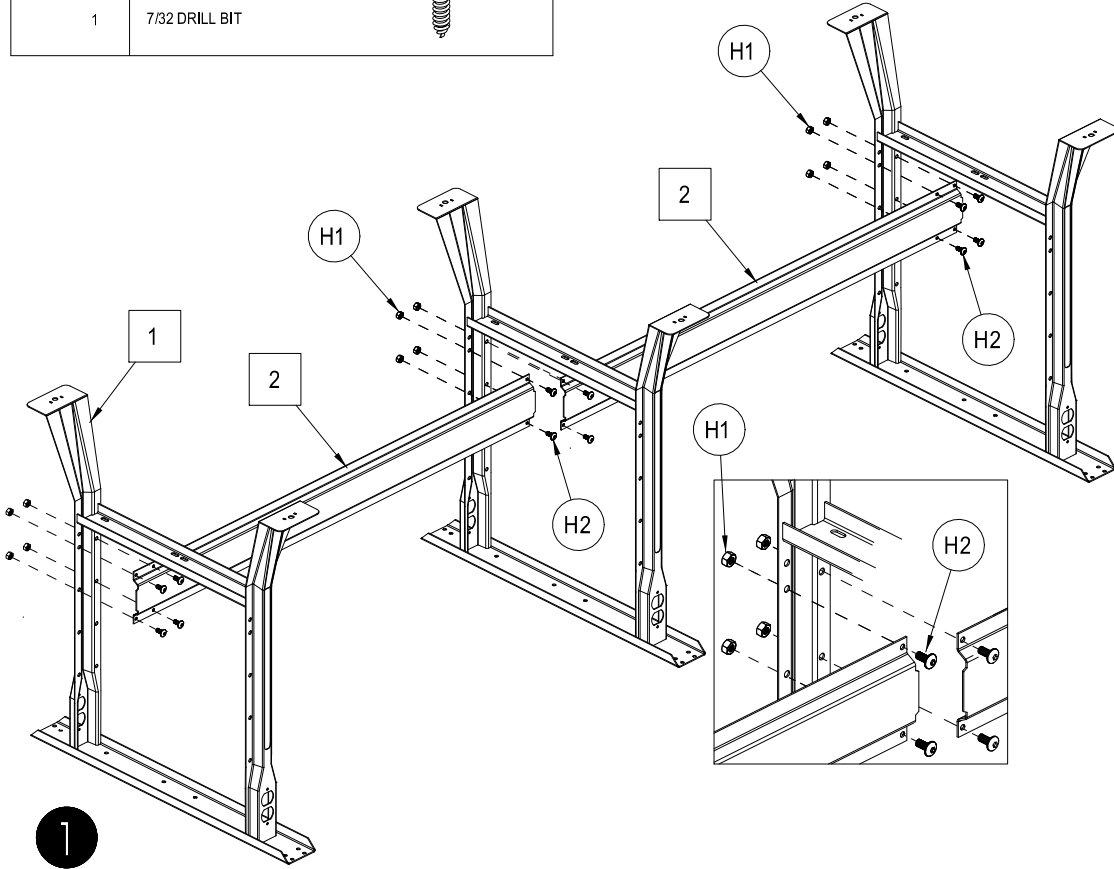

NOTE:
ALIGN BENCH FRAME
TO TOP

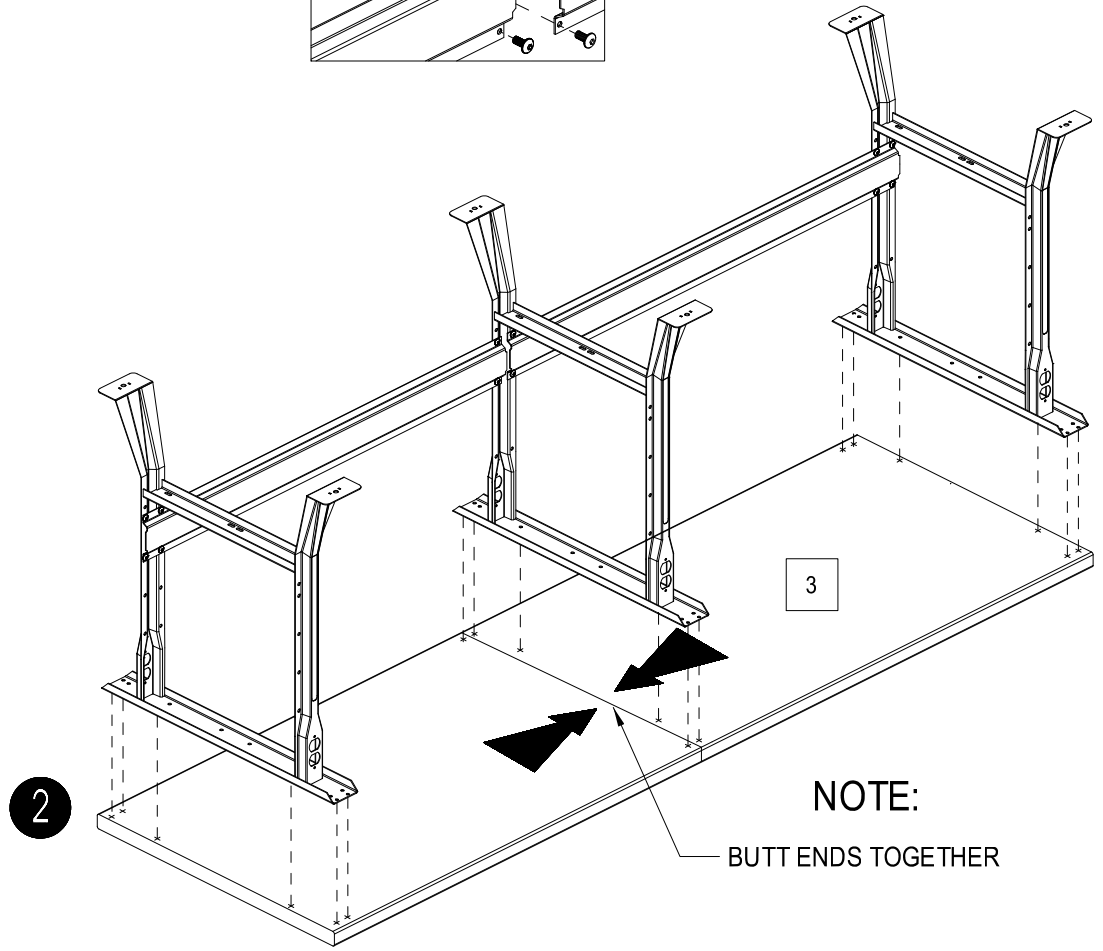

NOTE:
BUTT ENDS TOGETHER

3

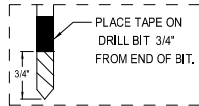
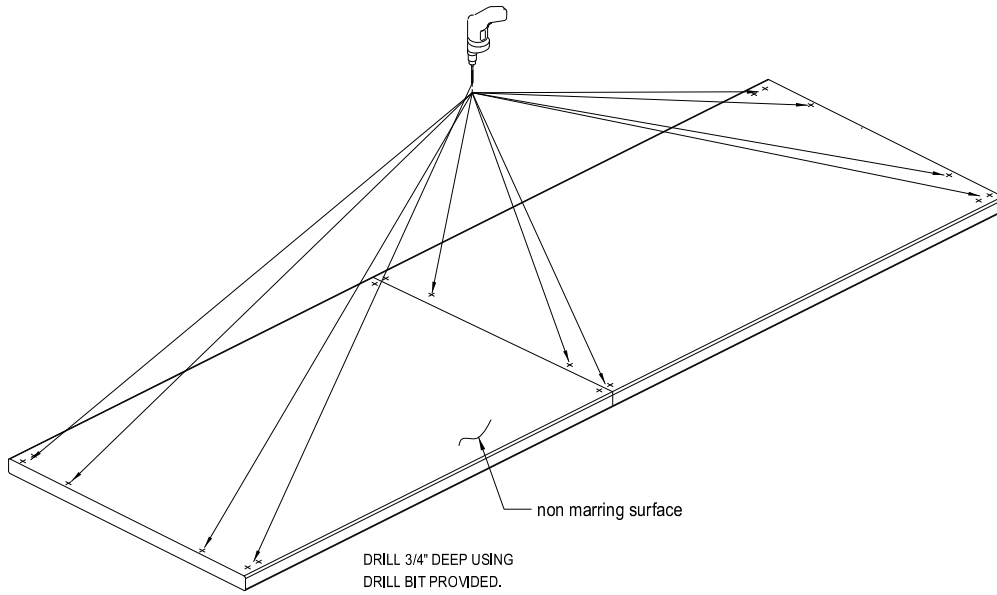

4

