

16 Person Locker Assembly

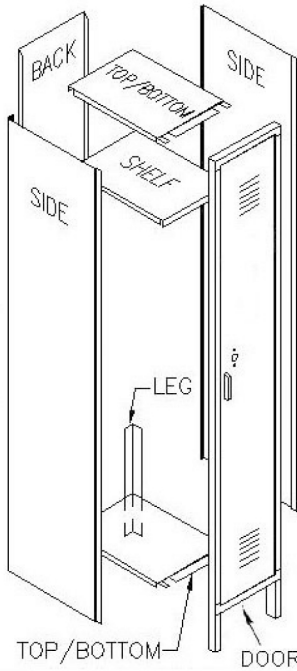

Before Assembly

Please read the complete instructions.

Check for missing or damaged parts.

Only use the specified hardware.

CAUTION: Some parts have sharp edges and corners, wear gloves during assembly.

Assembly will require the following tools:

- 2 drift pins (or 2 nail punches) for hole alignment
- 3/8" socket wrench

Lockers should be assembled on a flat, level surface and anchored according to the instructions found in Section 7 & 9.



16 Person Locker

Locker Assembly

1. Bolt together top and bottom with bends facing down and the back with the bends facing up. Top and bottom are identical. For single and double-tier models, bolt hook to back.

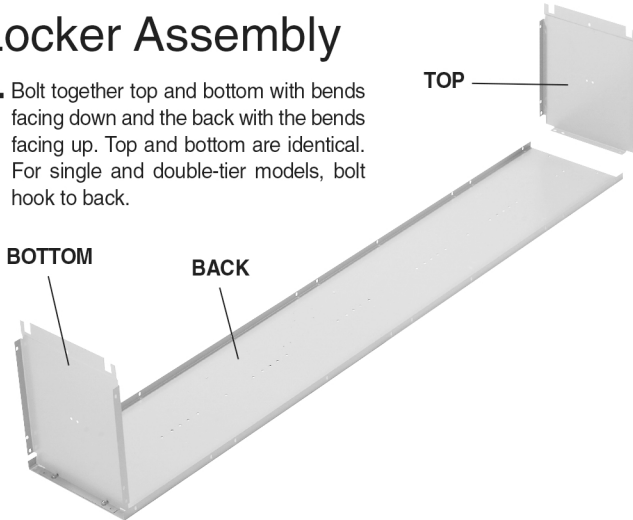

2. Bolt on side with bend in rear and facing in. Omit 2 bolts near bottom rear for legs. Install shelf by bolting to side with bend facing down and 45° bend in front. (See Section 7 Punching Patterns for single, double and 6-tier shelf hole locations.)

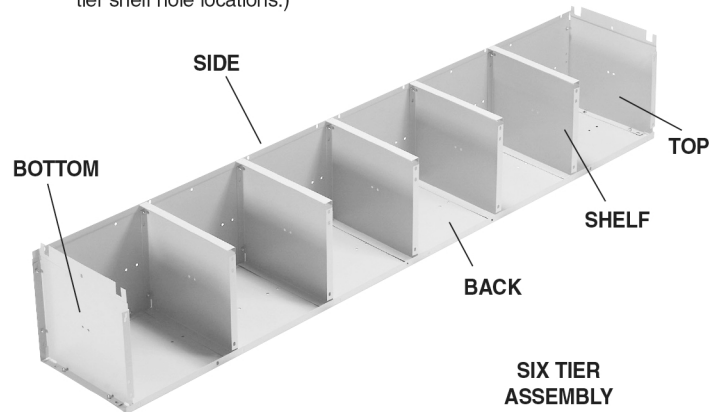

SIX TIER ASSEMBLY

3. Bolt on other side with rear bend facing in.

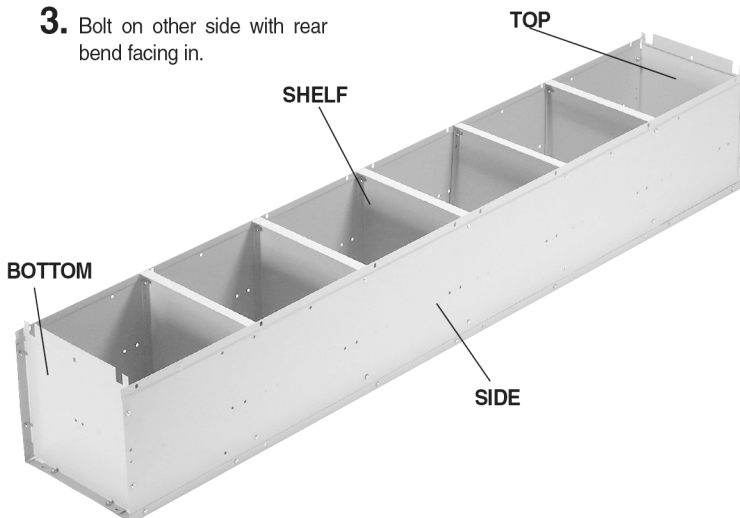

4. Insert rear legs in each end of locker. Bolt each leg in two places.

Attach Door Frame Assembly. Leave top, center and bottom bolts out if attaching to additional lockers.

