

## 16 Person Locker Assembly

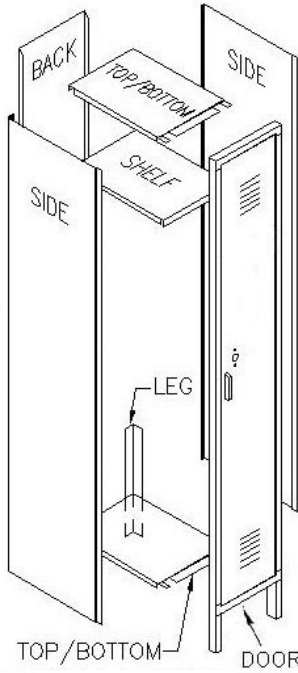

### Before Assembly

Please read the complete instructions.

Check for missing or damaged parts.

Only use the specified hardware.

**CAUTION:** Some parts have sharp edges and corners, wear gloves during assembly.

Assembly will require the following tools:

- 2 drift pins (or 2 nail punches) for hole alignment
- 3/8" socket wrench

Lockers should be assembled on a flat, level surface and anchored according to the instructions found in Section 7 & 9.



16 Person Locker

### Locker Assembly

- 1.** Bolt together top and bottom with bends facing down and the back with the bends facing up. Top and bottom are identical. For single and double-tier models, bolt hook to back.

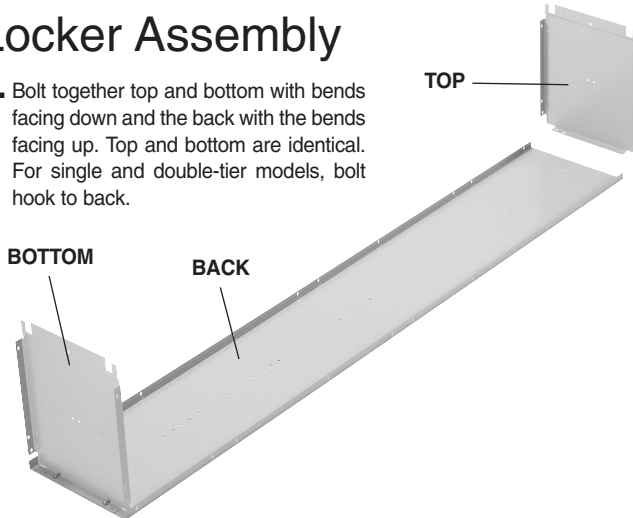

- 2.** Bolt on side with bend in rear and facing in. Omit 2 bolts near bottom rear for legs. Install shelf by bolting to side with bend facing down and 45° bend in front. (See Section 7 Punching Patterns for single, double and 6-tier shelf hole locations.)

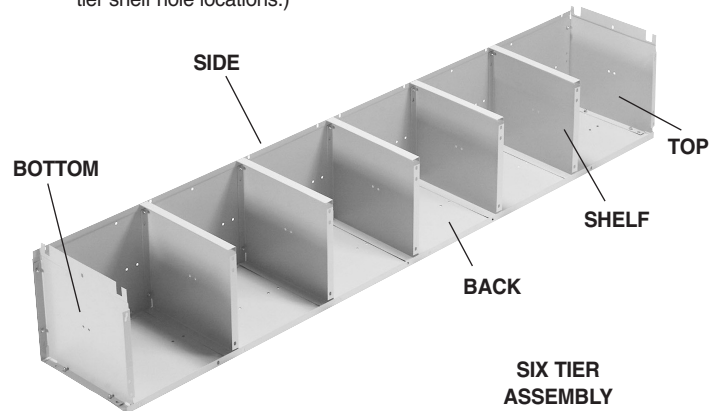

SIX TIER ASSEMBLY

- 3.** Bolt on other side with rear bend facing in.

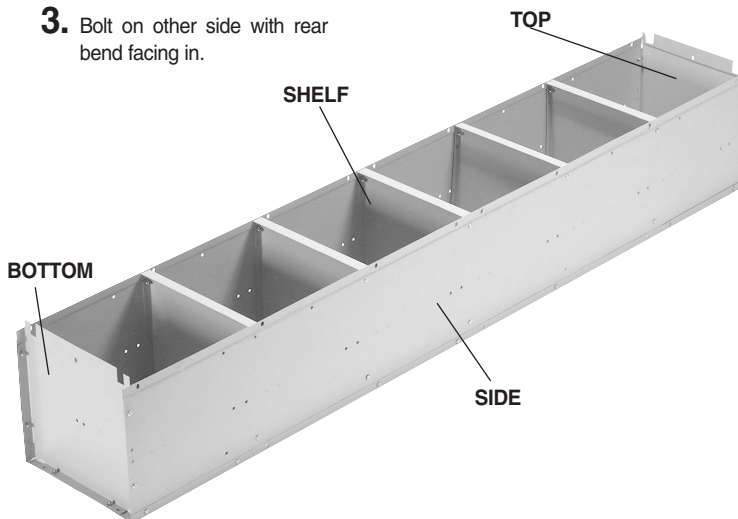

- 4.** Insert rear legs in each end of locker. Bolt each leg in two places.

Attach Door Frame Assembly. Leave top, center and bottom bolts out if attaching to additional lockers.

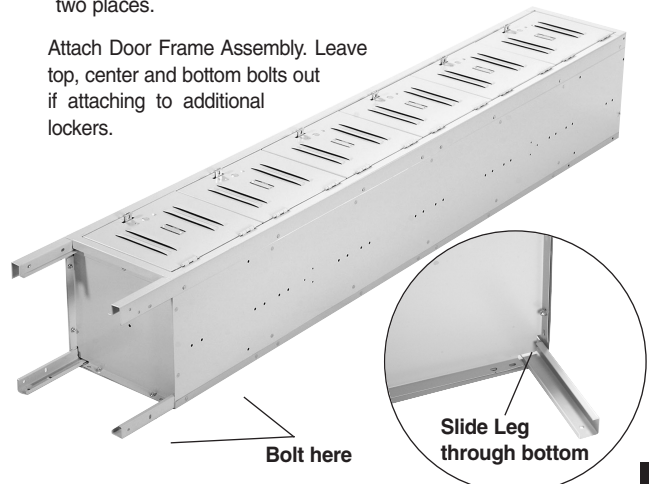

**5.** Bolt locker foot to leg.

For closed base assembly, see instructions included with base.

\*REPEAT STEPS 1-6 FOR OPPOSITE SIDE

**WARNING:**  
-FLOOR ANCHOR MUST HAVE A MINIMUM PULL-OUT VALUE OF 190 LBS.  
-WALL ANCHOR MUST HAVE A MINIMUM PULL-OUT VALUE OF 150 LBS.

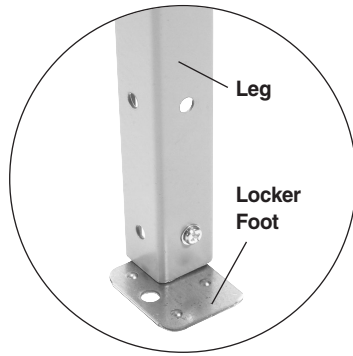

# Bridge Assembly

**1.** Bolt together top and back with bends on top facing down and the back with the bends facing up. Top and bottom are identical.

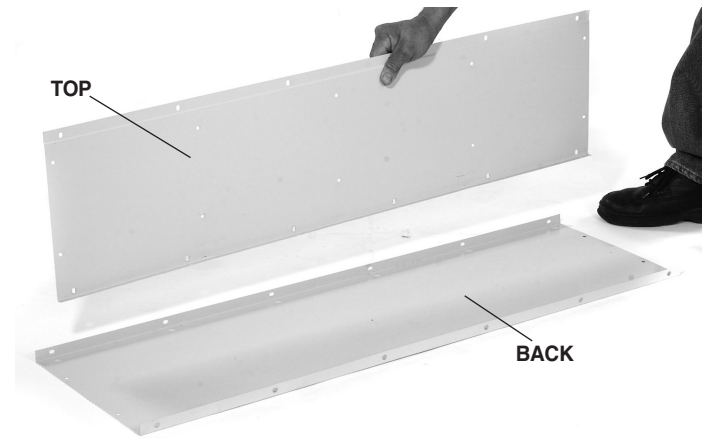

**2.** Bolt on bottom with bend facing in.

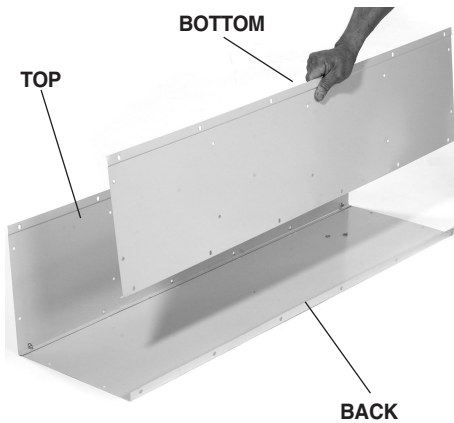

**3.** Bolt together tops, bottoms, and backs with a side in between.

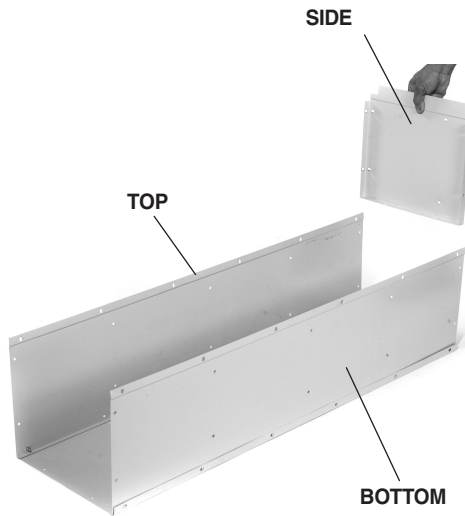

**4.** Repeat step 3 with other side.

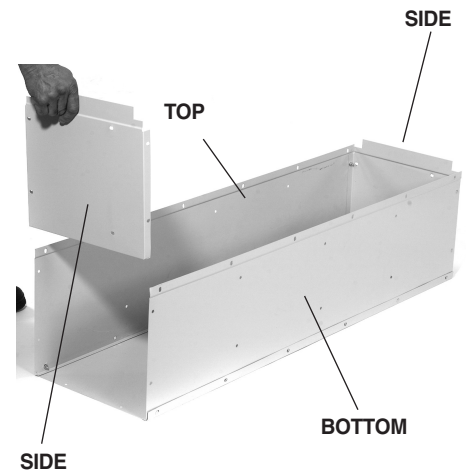

**5.** Bolt 3 doors to top and bottom.

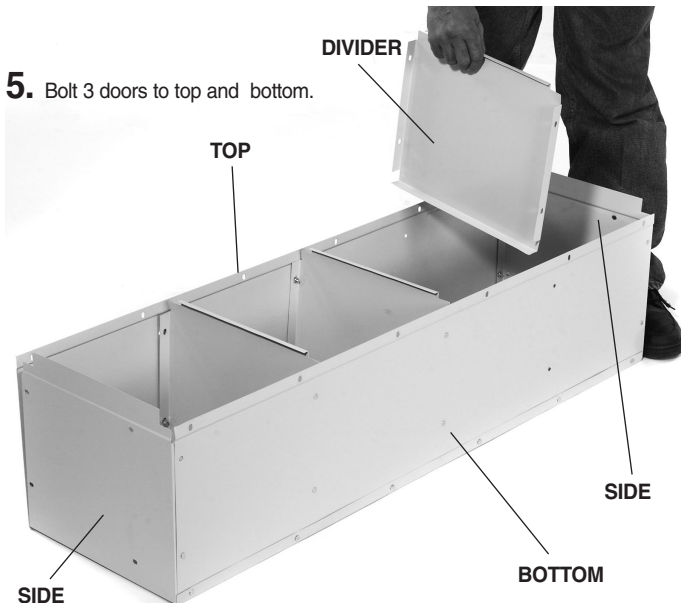

**6.** Attach door frame assembly.

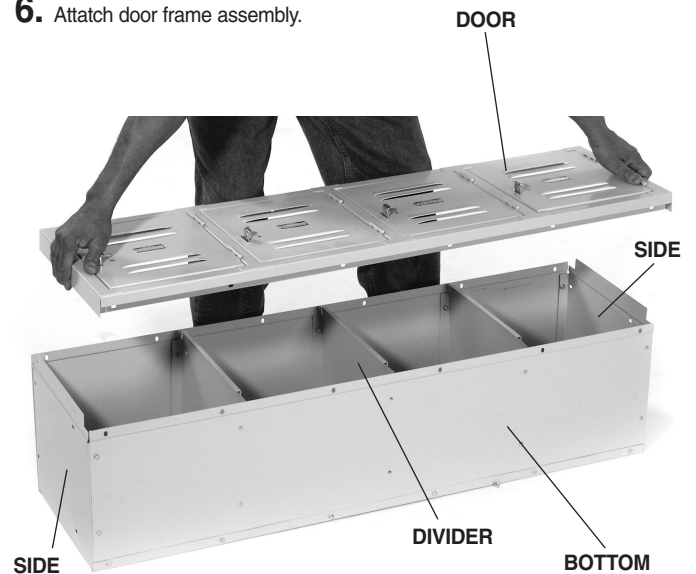

**7.** Bolt bridge assembly to six tier locker using 4 screws on each side.

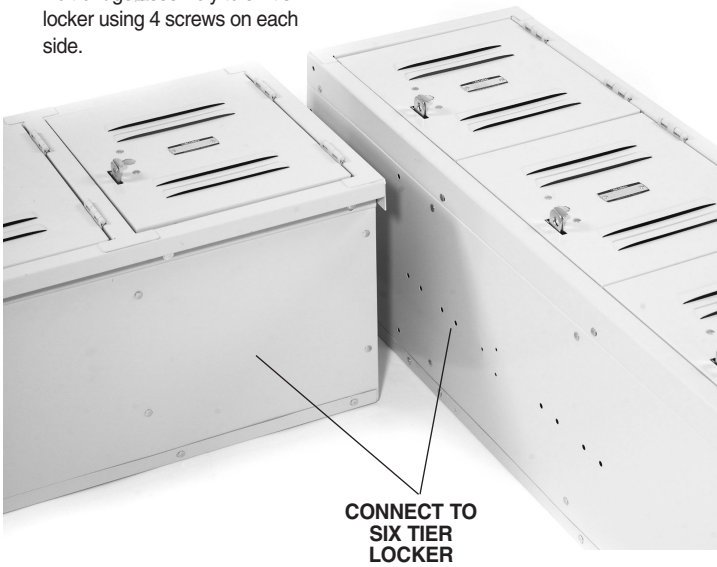

**8.** Repeat for other side.

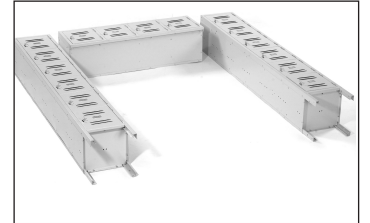
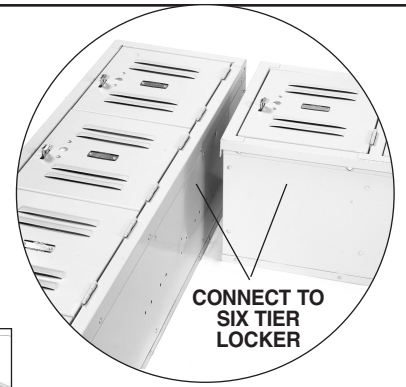

**9.** Bolt coat rod fitting to one side of six tier locker.



**10A.** Slide other coat rod fitting over rod.

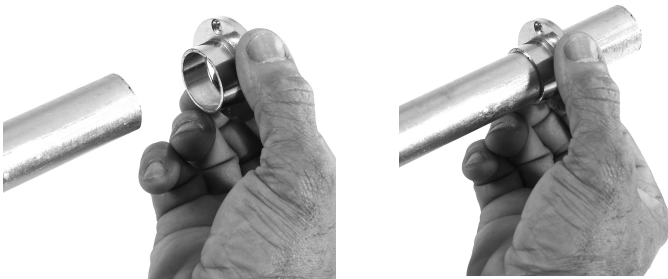

**11.** Attach fitting to other side.



**12.** Stand up locker and anchor to floor.

