



REFERENCE DRAWINGS

SPRAY NOZZLES - STRAIGHT	9971-000-001
SPRAY NOZZLES - ELBOW	9971-001-001
MULTI-PURPOSE WRENCH	9951-000-001
MX T/P VALVE ADJUSTMENT	9912-252-002
SOAP DISPENSERS	9912-260-002
TOWEL DISPENSER	9912-250-001
SUPPLY & VENT COVER	9912-251-001

PRODUCT ROUGH-IN AND INSTALLATION REQUIRES THE FOLLOWING MATERIALS NOT SUPPLIED BY ACORN ENGINEERING COMPANY.

- 1-1/2" IPS VENT PIPE ON -TT AND -BT MODELS.
- 3/4" NCT SUPPLIES TO VALVE ASSEMBLY.
- 2" NO HUB CONNECTOR, DRAINLINE AND WASTE FITTINGS.
- SUITABLE FLOOR ANCHORS FOR FIXTURE MOUNTING.
- FLEXIBLE SUPPLY CONNECTIONS TO 1/2" NPT INLETS.

MODEL #3508-F, #3508DBS-F

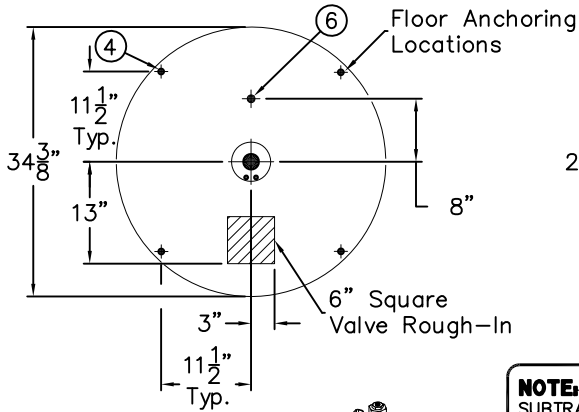

MODEL 3508-H, #3508DBS-H

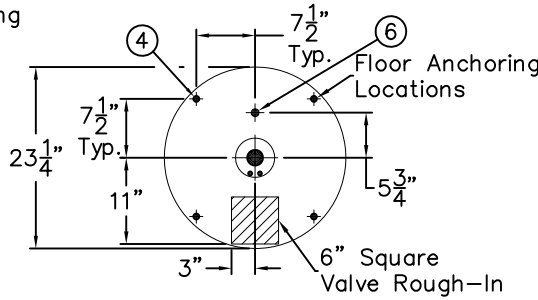

MODEL #3508ADA

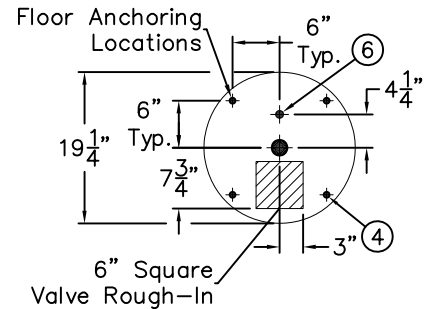

NOTE: FOR UNITS WITH -JH JUNIOR RIM HEIGHT, SUBTRACT DIFFERENCE FROM ALL VERTICAL DIMENSIONS INDICATED WITH **.

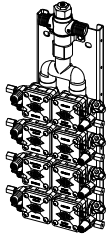

VALVE DETAIL
Scaled x 2

BOWL STYLE	DIM "A"
STANDARD	18-3/4"
-DBS DEEP BOWL	16-1/2"

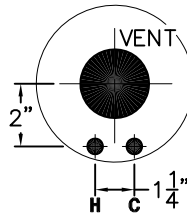

-TT DETAIL
Scaled x 4

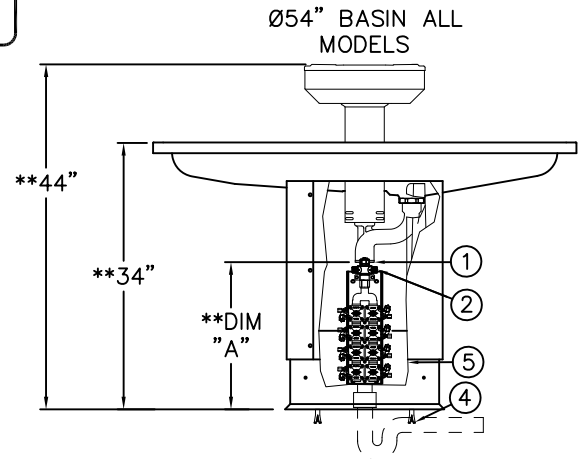

ROUGH-IN FOR THE FOLLOWING:

- BASIN WASTE 2" O.D. TAILPIECE (1) NO HUB CONNECTION.
- HOT & COLD SUPPLIES FOR MIXING VALVE WITH 1/2" NPT VALVE INLETS (2).
- FIXTURE FLOOR ANCHORING: 1/2" Ø PUNCHING (3) FOR INSTALLER PROVIDED ANCHORS AND ANCHORING HARDWARE (4).

INSTALLATION INSTRUCTIONS:

- A- REMOVE PEDESTAL SKIRT QUARTER PANEL (5).
- B- MAKE UP INSTALLER PROVIDED WASTE (2" NO HUB) CONNECTION AND VENT (1-1/2" IPS) CONNECTION IF NECESSARY.
- C- INSTALL FLOOR ANCHORS (4), AND ATTACH FIXTURE TO THE FLOOR, ANCHORS AND ANCHOR HARDWARE INSTALLER PROVIDED.
- D- FLUSH SUPPLY LINES PRIOR TO MAKING UP CONNECTIONS TO 1/2" NPT VALVE INLET CONNECTIONS (2).
- E- ADJUST MIXING VALVE TO DESIRED TEMPERATURE. REFER TO DRAWING 9912-252-001.

- F- SET TIMING CYCLE ON METERING VALVES; SEE DRAWING 9955-000-003 FOR DETAILS AND INSTRUCTIONS.
- G- REINSTALL PEDESTAL SKIRT QUARTER PANEL.

FOR -SO SENSOR OPERATION: SUPPLY 120VAC, 60 Hz, 3 AMPS (MAX) POWER TO FACTORY INSTALLED TRANSFORMER (WITH JUNCTION BOX). LOCATE ELECTRICAL STUB OUT (6) WITHIN SHADED ROUGH-IN AREA.

NOTE: FIXTURE MUST BE EARTH GROUNDED PER N.E.C. (NATIONAL ELECTRICAL CODE). TRANSFORMER MUST BE WIRED TO A GFI PROTECTED CIRCUIT.

NOTE: MAXIMUM RECOMMENDED WORKING WATER PRESSURE IS 100 PSI; TEMPERATURE IS 130°F; OUTLET TEMPERATURE IS RECOMMENDED AT A MAXIMUM OF 105°F.

WARNING: PRIOR TO MAKING INSTALLATION, SUPPLY LINES MUST BE FLUSHED OF ALL FOREIGN MATERIAL SUCH AS PIPE DOPE, CHIPS, ETC. VALVE MUST BE DRAINED PRIOR TO BEING SUBJECTED TO FREEZING TEMPERATURES. MAXIMUM RECOMMENDED OUTLET WATER TEMPERATURE IS 105°F.



ACORN ENGINEERING COMPANY
P.O. BOX 3527 INDUSTRY, CA. 91744
(626) 336-4561 FAX (626) 961-2200

TITLE		
8 PERSON WASHFOUNTIAN - CAT* 3508, 3508ADA & 3508DBS		
MANUFACTURE DATE	DATE ISSUED	DRAWING NUMBER
OCTOBER 1999	06/04/10	9912-210-004
TO PRESENT	DATE REVISED	
	03/25/14 B	

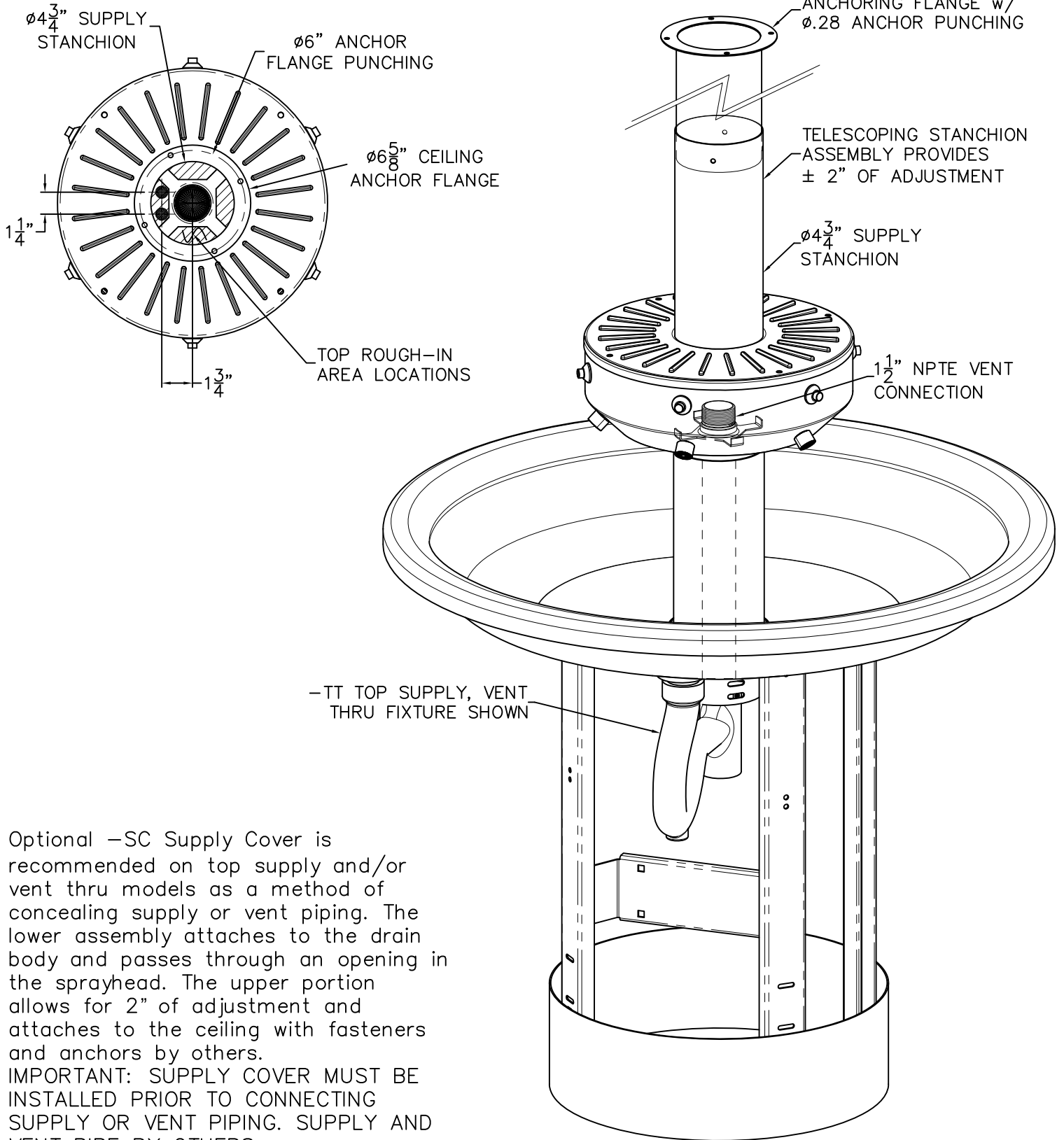

Optional -SC Supply Cover is recommended on top supply and/or vent thru models as a method of concealing supply or vent piping. The lower assembly attaches to the drain body and passes through an opening in the sprayhead. The upper portion allows for 2" of adjustment and attaches to the ceiling with fasteners and anchors by others. IMPORTANT: SUPPLY COVER MUST BE INSTALLED PRIOR TO CONNECTING SUPPLY OR VENT PIPING. SUPPLY AND VENT PIPE BY OTHERS.



ACORN ENGINEERING COMPANY
 P.O. BOX 3527 Industry, CA 91744
 15125 Proctor Ave Industry, CA 91746
 (626) 336-4561 FAX (626) 961-2200

TITLE -SC SUPPLY & VENT COVER DETAIL		
MANUFACTURE DATE DECEMBER 1986 TO PRESENT	DATE ISSUED 03/01/94	DRAWING NUMBER 9912-251-001
	DATE REVISED 06/13/13	



REFERENCE DRAWINGS	
SOAP DISPENSERS	9912-260-002
SUPPLY & VENT COVERS	9912-251-001

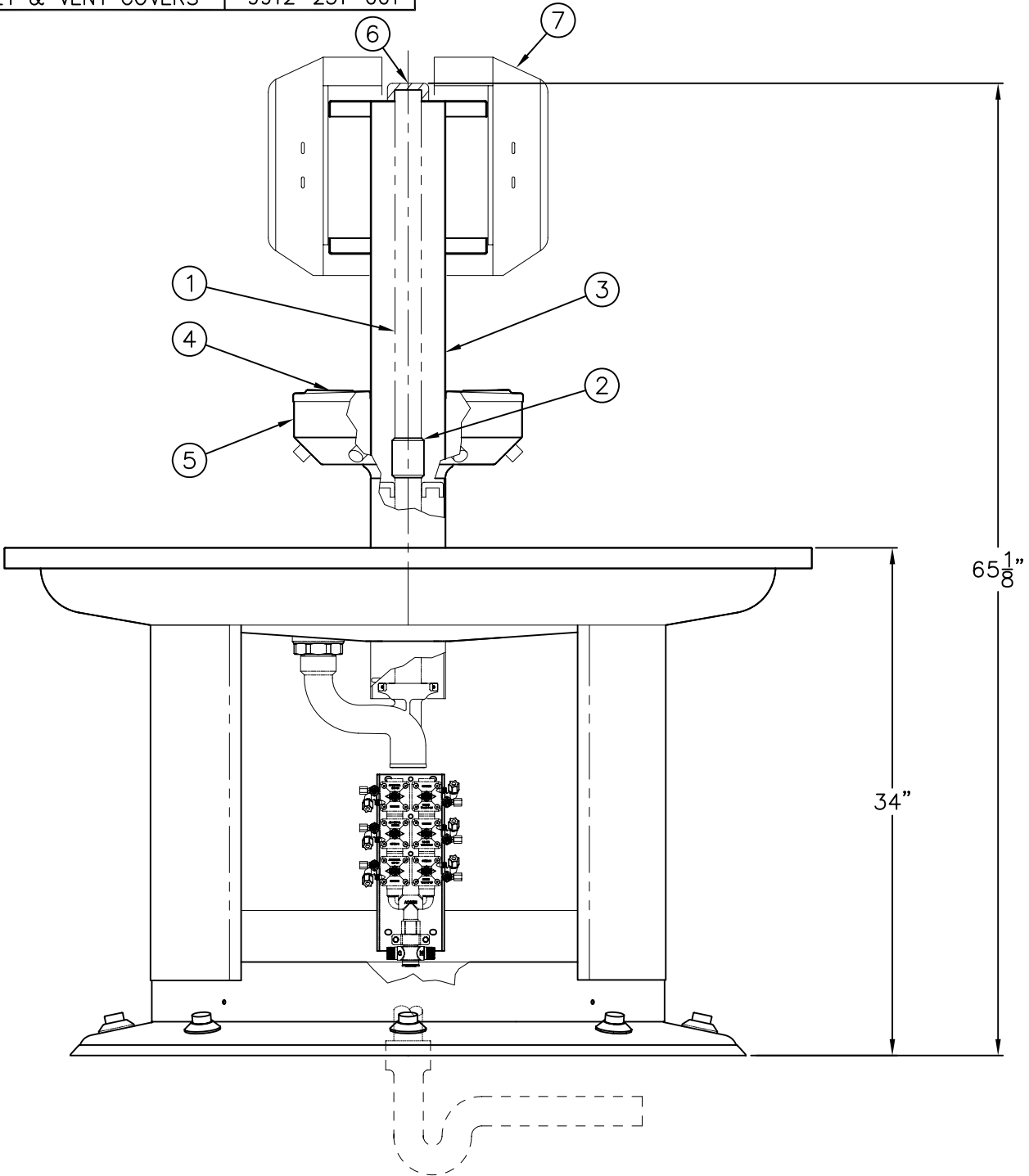

INSTALLATION INSTRUCTIONS

- A- SCREW 21-1/2" LONG REINFORCING PIPE (1) INTO COUPLING (2).
- B- INSERT TOWEL DISPENSER BRACKET ASSEMBLY (3) OVER REINFORCING PIPE (1).

- C- ATTACH LID (4) TO SPRAYHEAD (5) WITH FASTENERS PROVIDED. INSTALL PIPE CAP (6).
- D- ATTACH TOWEL DISPENSER (7) (FASTENERS PROVIDED).



ACORN ENGINEERING COMPANY
 P.O. BOX 3527 INDUSTRY, CA. 91744
 (626) 336-4561 FAX (626) 961-2200

TITLE TOWEL DISPENSER BRACKET INSTALLATION		
MANUFACTURE DATE AUG 1985 TO PRESENT	DATE ISSUED 12/1/89	DRAWING NUMBER 9912-250-002
	DATE REVISED 05/21/10	

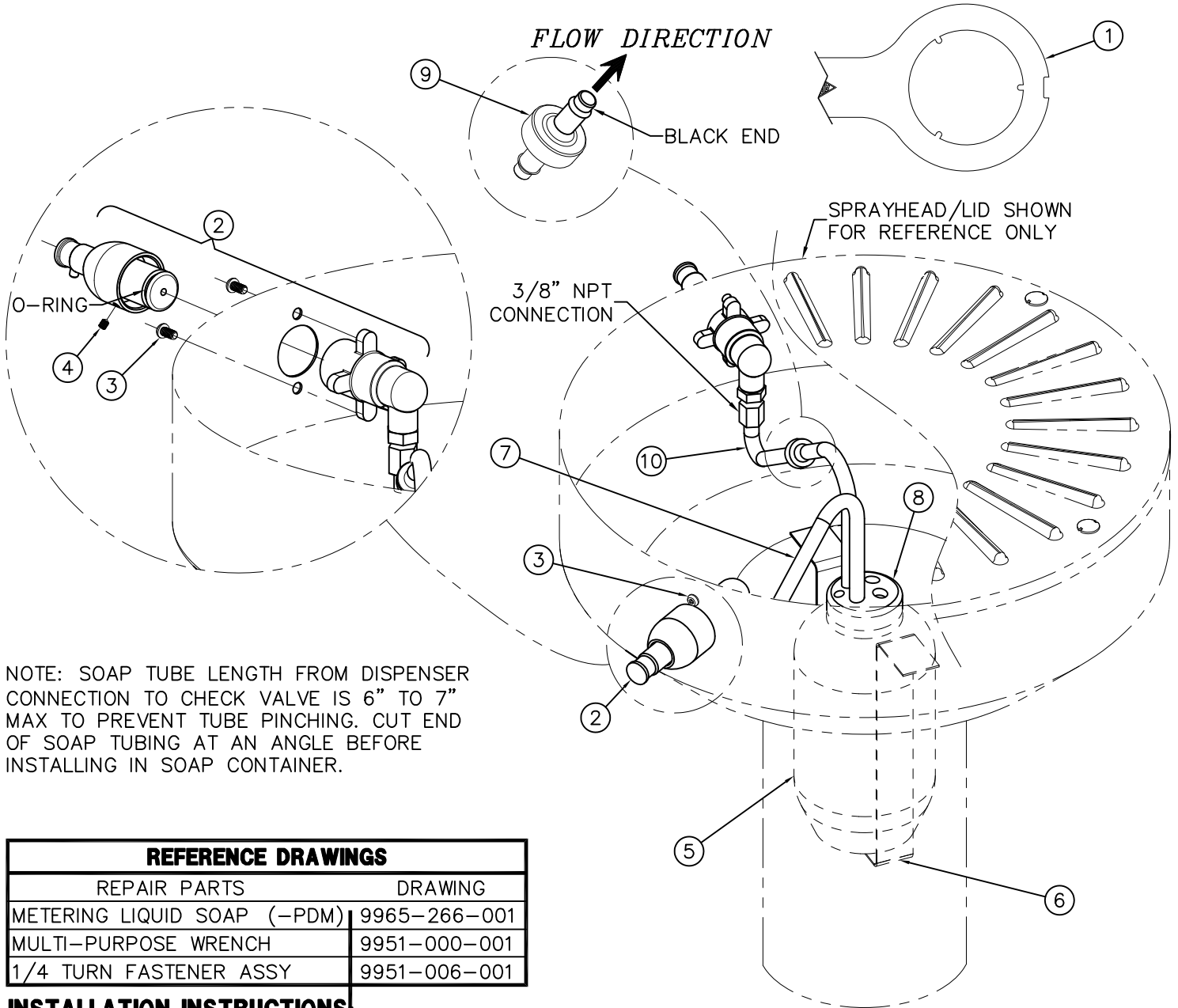

NOTE: SOAP TUBE LENGTH FROM DISPENSER CONNECTION TO CHECK VALVE IS 6" TO 7" MAX TO PREVENT TUBE PINCHING. CUT END OF SOAP TUBING AT AN ANGLE BEFORE INSTALLING IN SOAP CONTAINER.

REFERENCE DRAWINGS	
REPAIR PARTS	DRAWING
METERING LIQUID SOAP (-PDM)	9965-266-001
MULTI-PURPOSE WRENCH	9951-000-001
1/4 TURN FASTENER ASSY	9951-006-001

INSTALLATION INSTRUCTIONS

- A- WITH WRENCH (1) PROVIDED REMOVE THE SPRAYHEAD LID.
- B- ASSEMBLE LIQUID PUMP SOAP DISPENSER (2) AND MOUNT ONTO SPRAYHEAD AS SHOWN ABOVE USING CENTER SET SCREW (3) AND POINT HEAD SET SCREW (4).
- D- PLACE LIQUID SOAP CONTAINER (5) INSIDE SPRAYHEAD ONTO THE LIQUID SOAP CONTAINER BRACKET (6).
- E- INSERT 3/8" OD VINYL TUBE (7) INTO LIQUID SOAP CONTAINER (5) THROUGH HOLES ON CONTAINER LID (8) AND CONNECT OTHER END TO CHECK VALVE (9).
- F- CONNECT 3/8" OD VINYL TUBE (10) FROM CHECK VALVE (9) TO LIQUID SOAP PUMP DISPENSER (2).
- G- FILL LIQUID SOAP CONTAINER (5) WITH LIQUID SOAP AND PRIME LIQUID SOAP PUMP (2).
- H- SECURE SPRAYHEAD LID USING WRENCH PROVIDED (1) & TURNING FASTENERS (2) 1/4 TURN CLOCKWISE.

ACORN ENGINEERING COMPANY P.O. BOX 3527 Industry, CA 91744 15125 Proctor Ave Industry, CA 91746 (626) 336-4561 FAX (626) 961-2200	TITLE -PDM METERING LIQUID SOAP INSTALLATION DETAIL		
	MANUFACTURE DATE MARCH 2013 TO PRESENT	DATE ISSUED 03/20/13	DRAWING NUMBER 9912-263-001



REPAIR PARTS		DRAWING
POWDERED SOAP	(-DP)	9965-200-001
LOTION SOAP	(-DV)	9965-230-002
METERING LIQUID SOAP	(-PDM)	9965-266-001
MULTI-PURPOSE WRENCH		9951-000-001
1/4 TURN FASTENER ASSY		9951-006-001

NOTE:
WHEN RETROFITTING TO A UNIT WITH A TOP SUPPLY OR VENT, ALL THROUGH TOP CONNECTIONS MUST BE DISCONNECTED PRIOR TO INSTALLATION.

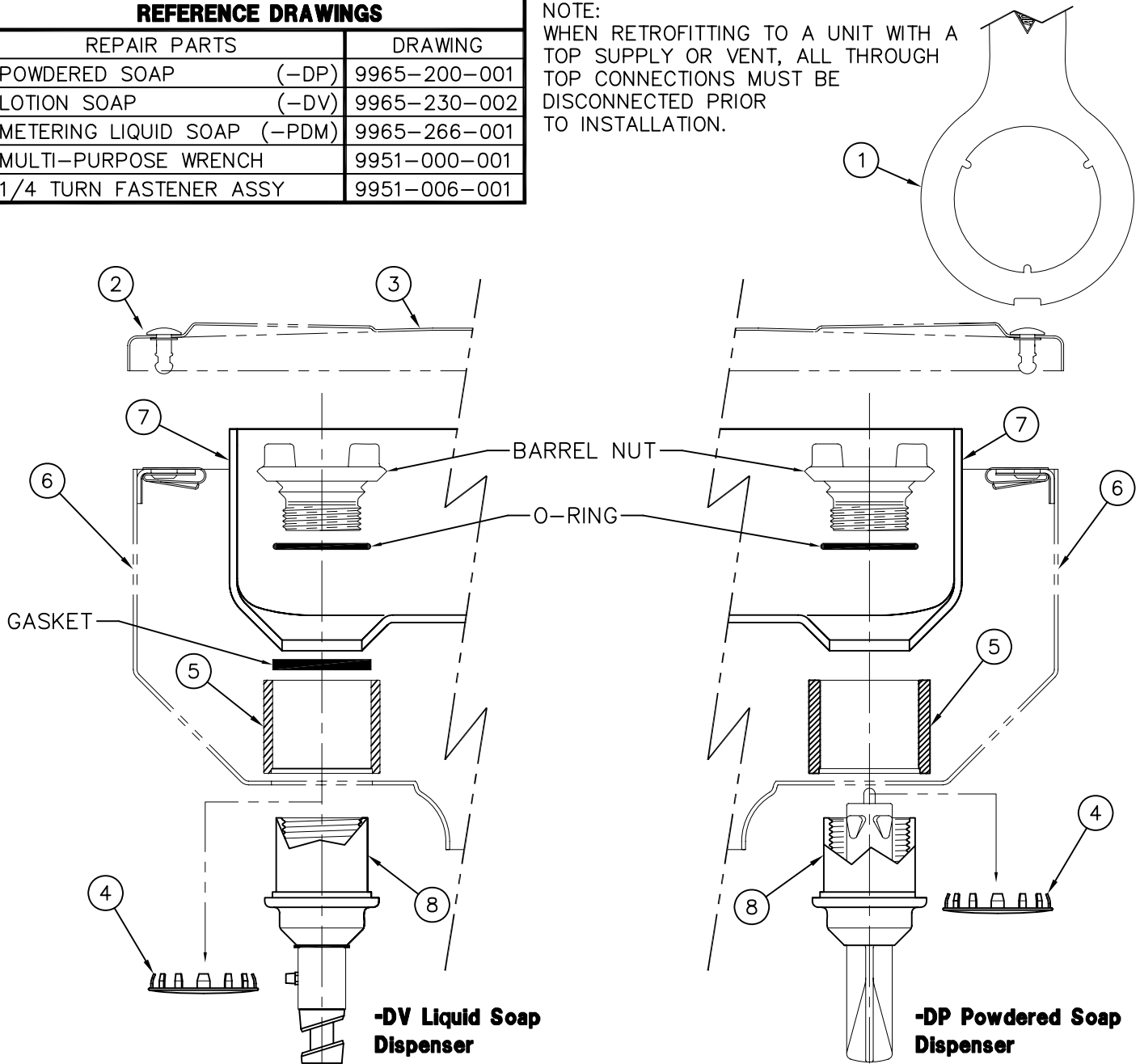

SOAP DISPENSER/TANK INSTALLATION DETAIL

- A- WITH WRENCH ① PROVIDED GIVE LID FASTENERS ② A QUARTER TURN COUNTERCLOCKWISE AND REMOVE LID ③.
- B- REMOVE SOAP DISPENSER PLUGS ④. (DISCARD)
- C- POSITION BARREL STANDOFFS ⑤ OVER HOLES IN SPRAYHEAD ⑥.
- D- PLACE SOAP TANK ⑦ INSIDE SPRAYHEAD ALIGNING OPENINGS IN TANK WITH STANDOFFS ⑤.

- E- ASSEMBLE SOAP DISPENSERS ⑧ FROM INSIDE SOAP TANK AND BELOW SPRAYHEAD AS SHOWN ABOVE.
- F- FILL SOAP TANK ⑦ WITH SOAP.
- G- SECURE LID ③ USING SPECIAL WRENCH ① & TURNING FASTENERS ② 1/4 TURN CLOCKWISE.

ACORN ENGINEERING COMPANY
P.O. BOX 3527 INDUSTRY, CA. 91744
(626) 336-4561 FAX (626) 961-2200

TITLE SOAP DISPENSER/TANK INSTALLATION DETAIL		
MANUFACTURE DATE MARCH 1987 TO PRESENT	DATE ISSUED 08/24/09	DRAWING NUMBER 9912-260-002
	DATE REVISED	

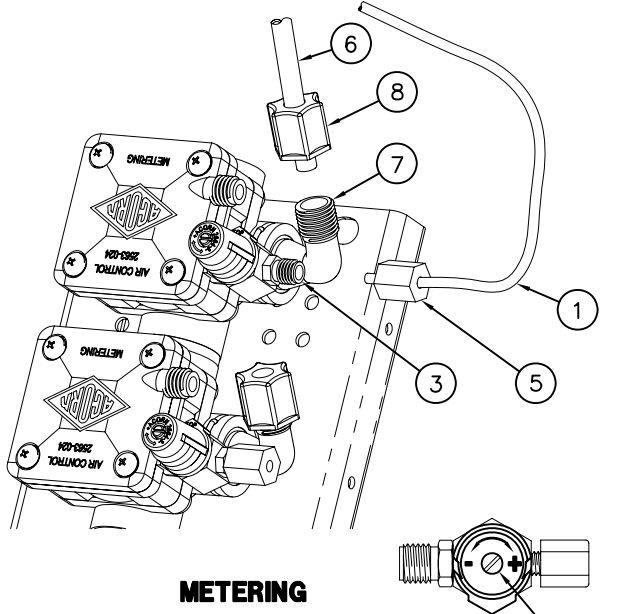
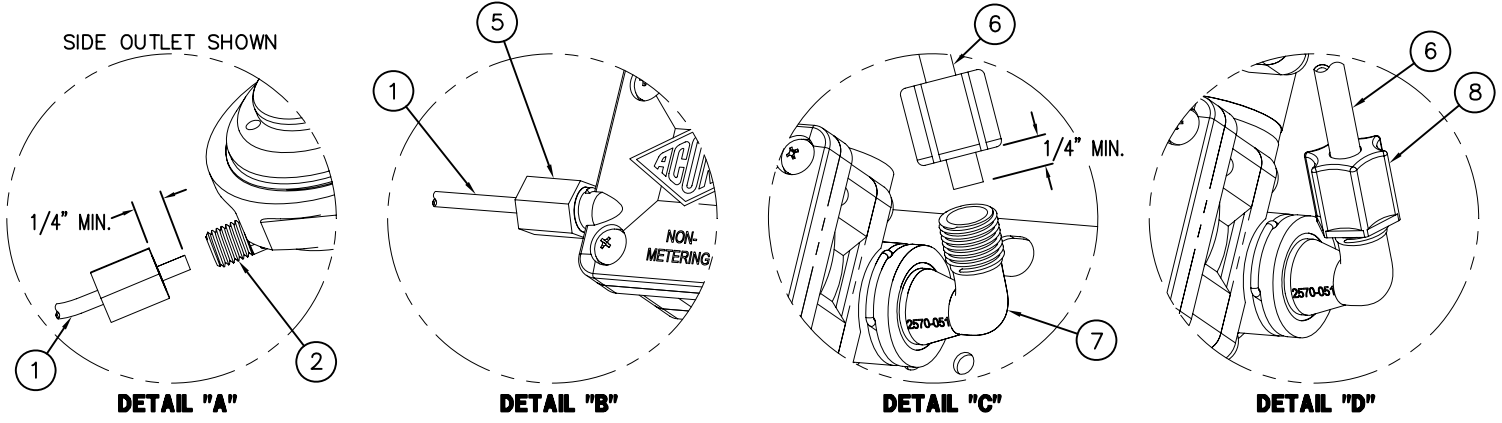

METERING

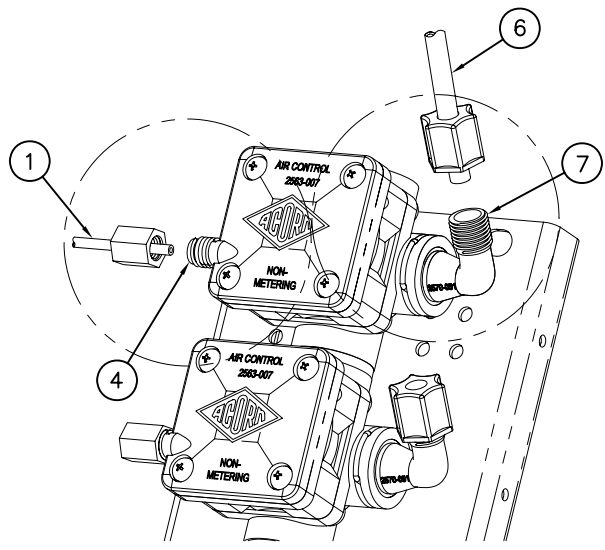

NON-METERING DIRECT ACTING

TIMING IS ADJUSTABLE FROM 5 TO 60 SECONDS AND IS ACCOMPLISHED BY ROTATING TIMING SCREW. TURING THE SCREW CLOCKWISE INCREASES WHILE COUNTERCLOCKWISE DECREASES TIMING.

REFERENCE DRAWINGS	
ASSEMBLIES	DRAWING
VALVE BODY	9955-006-003
CHECKSTOP	9956-040-003
FIXTURE TRIM	9957-051-001
AIR-CONTROL SERVOMOTORS	
METERING	9955-000-003
NON-METERING	9955-001-003

INSTALLATION INSTRUCTIONS:

- A- MOUNT FIXTURE IN ACCORDANCE TO MANUFACTURER'S INSTALLATION INSTRUCTIONS.
- B- ASSEMBLE SPOUTS AND PUSHBUTTONS TO FIXTURE.
- C- CONNECT 1/8" O.D. POLYETHYLENE AIR LINE ① TO PUSHBUTTON ②, AND VALVE TIMER ASSEMBLY ③ SEE DETAIL "A". NOTE: FOR DIRECT ACTING: ASSEMBLE TO AIR PORT ④, SEE DETAIL "B". HAND TIGHTEN FERRULE NUT ⑤ PROVIDED.
- D- CONNECT 1/4" O.D. POLYETHYLENE WATER LINES ⑥ TO VALVE ASSEMBLY ELBOW ⑦ SEE DETAILS "C", AND "D". HAND TIGHTEN FERRULE NUT ⑧ PROVIDED.
- E- AFTER THOROUGHLY FLUSHING SUPPLY LINES MAKE UP CONNECTIONS TO VALVE ASSEMBLY INLET(S) 1/2" NPT OR 1/2" NPS FLEX HOSE AS REQUIRED.

NOTE:

- 1) ALL TUBING SHOULD BE CUT SQUARE AND BE FREE OF BURRS OR DEFORMITIES TO ENSURE A WATER TIGHT CONNECTION.
- 2) EXTEND TUBING AT LEAST 1/4" BEYOND FERRULE NUT BEFORE INSERTING TUBING INTO CONNECTION OPENING BEFORE TIGHTENING.
- 3) TUBING SHOULD BE FREE OF KINKS FOR PROPER OPERATION
- 4) MAXIMUM RECOMMENDED WORKING WATER PRESSURE IS 100 PSI; TEMPERATURE IS 130° F; OUTLET TEMPERATURE IS RECOMMENDED AT A MAXIMUM OF 105° F.

WARNING:

PRIOR TO MAKING INSTALLATION, SUPPLY LINES MUST BE FLUSHED OF ALL FOREIGN MATERIAL SUCH AS PIPE DOPE, CHIPS, SOLDER, ETC. VALVE MUST BE DRAINED PRIOR TO BEING SUBJECTED TO FREEZING TEMPERATURES. MAXIMUM RECOMMENDED OUTLET WATER TEMPERATURE IS 105° F.

<p>ACORN ENGINEERING COMPANY P.O. BOX 3527 INDUSTRY, CA. 91744 (626) 338-4561 FAX (626) 961-2200</p>	<p>TITLE HAND OPERATED AIR-CONTROL VALVE CONNECTIONS</p>		
	<p>MANUFACTURE DATE</p> <p>JANUARY 1999</p> <p>TO PRESENT</p>	<p>DATE ISSUED</p> <p>04/22/10</p> <p>DATE REVISED</p> <p>10/11/10</p>	<p>DRAWING NUMBER</p> <p>9905-006-001</p>



REFERENCE DRAWINGS		
REPAIR PARTS		DRAWING
NON-METERING SERVOMOTOR	(-F)	9955-001-003
METERING SERVOMOTOR	(-H)	9955-000-003
AIR-CONTROL VALVE BODY		9975-090-001
CHECKSTOP	(-ST Single Temp. Only)	9956-040-003
SENSOR/SOLENOID	(-SO) (24VAC)	9955-015-002
SENSOR/SOLENOID/PPZ	(-SO) (9VDC)	9955-019-002
HAND BUTTON		9957-300-001
FOOT BUTTON		9957-200-001

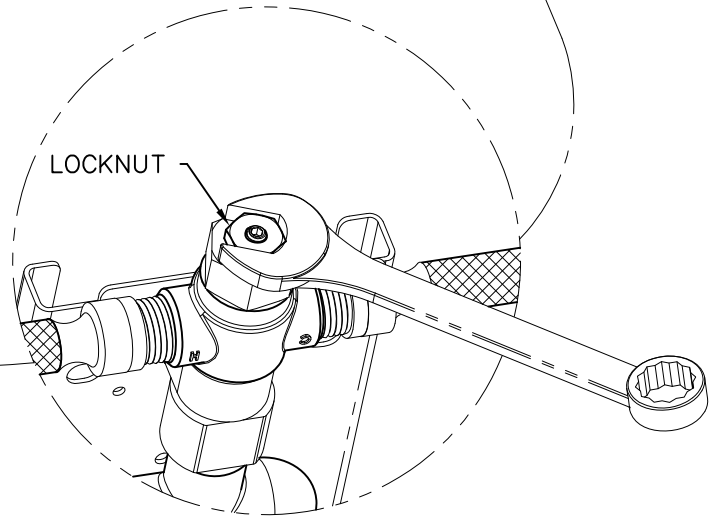
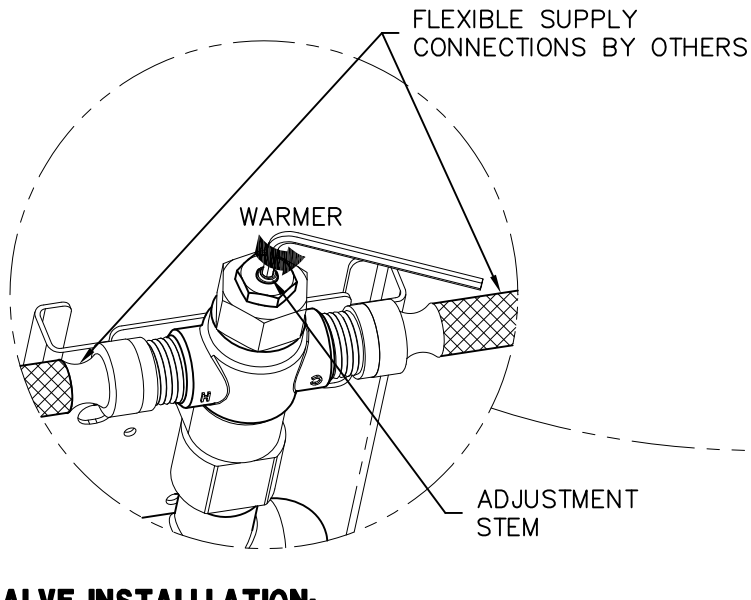
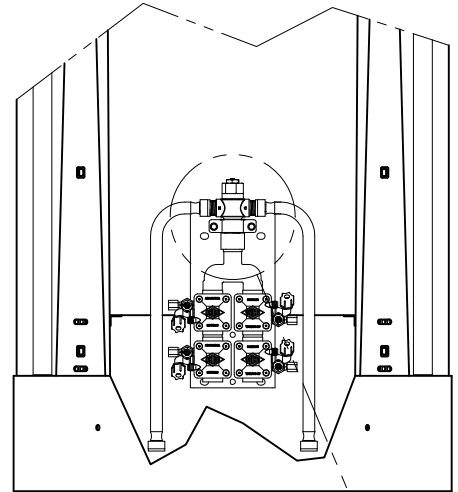

VALVE INSTALLATION:

- A- MX-T/P VALVES: AFTER THOROUGHLY FLUSHING SUPPLY LINES, MAKE UP CONNECTIONS TO SUPPLY STUB OUTS AND VALVE INLETS WITH INSTALLER PROVIDED FLEXIBLE HOSE. NOTE: MX-T/P VALVE SUPPLY INLETS ARE 1/2" NPT.
- B- OPTIONAL -ST (Single Temp): AFTER THOROUGHLY FLUSHING SUPPLY LINE, MAKE UP CONNECTION TO SUPPLY STUB OUT AND VALVE INLET WITH FLEXIBLE HOSE PROVIDED. NOTE: -ST VALVES INCLUDE FLEXIBLE HOSE WITH 1/2" NPSI CONNECTIONS. FLEXIBLE HOSE ENDS WILL ACCOMMODATE 1/2" NPT MALE ADAPTER.
- C- SEE APPROPRIATE SERVOMOTOR REFERENCE DRAWINGS FOR VALVE DETAILS AND TIMING INSTRUCTIONS.

MX T/P TEMPERATURE VALVE ADJUSTMENT

- D- LOOSEN LOCKNUT SHOWN.
- E- TURN ON FIXTURE AND RUN WATER FOR AT LEAST 2 MINUTES. ALLOW WATER TO STABILIZE.
- F- USE AN 1/8" ALLEN WRENCH TO TURN ADJUSTMENT STEM COUNTER-CLOCKWISE FOR WARMER OR CLOCKWISE FOR COOLER OUTLET WATER TEMPERATURE.
- G- TIGHTEN LOCKNUT TO PREVENT ACCIDENTAL OR UNAUTHORIZED TEMPERATURE ADJUSTMENT.
- H- RE-CHECK OUTLET TEMPERATURE.

<p>ACORN ENGINEERING COMPANY P.O. BOX 3527 Industry, CA 91744 15125 Proctor Ave Industry, CA 91746 (626) 336-4561 FAX (626) 961-2200</p>	<p>TITLE VALVE INSTALL & MIXING VALVE ADJUSTMENT</p>		
	<p>MANUFACTURE DATE</p> <p>MARCH 2014</p> <p>TO PRESENT</p>	<p>DATE ISSUED</p> <p>03/25/14</p> <hr/> <p>DATE REVISED</p>	<p>DRAWING NUMBER</p> <p>9912-252-002</p>



TWO STATION WIRING DIAGRAM SHOWN

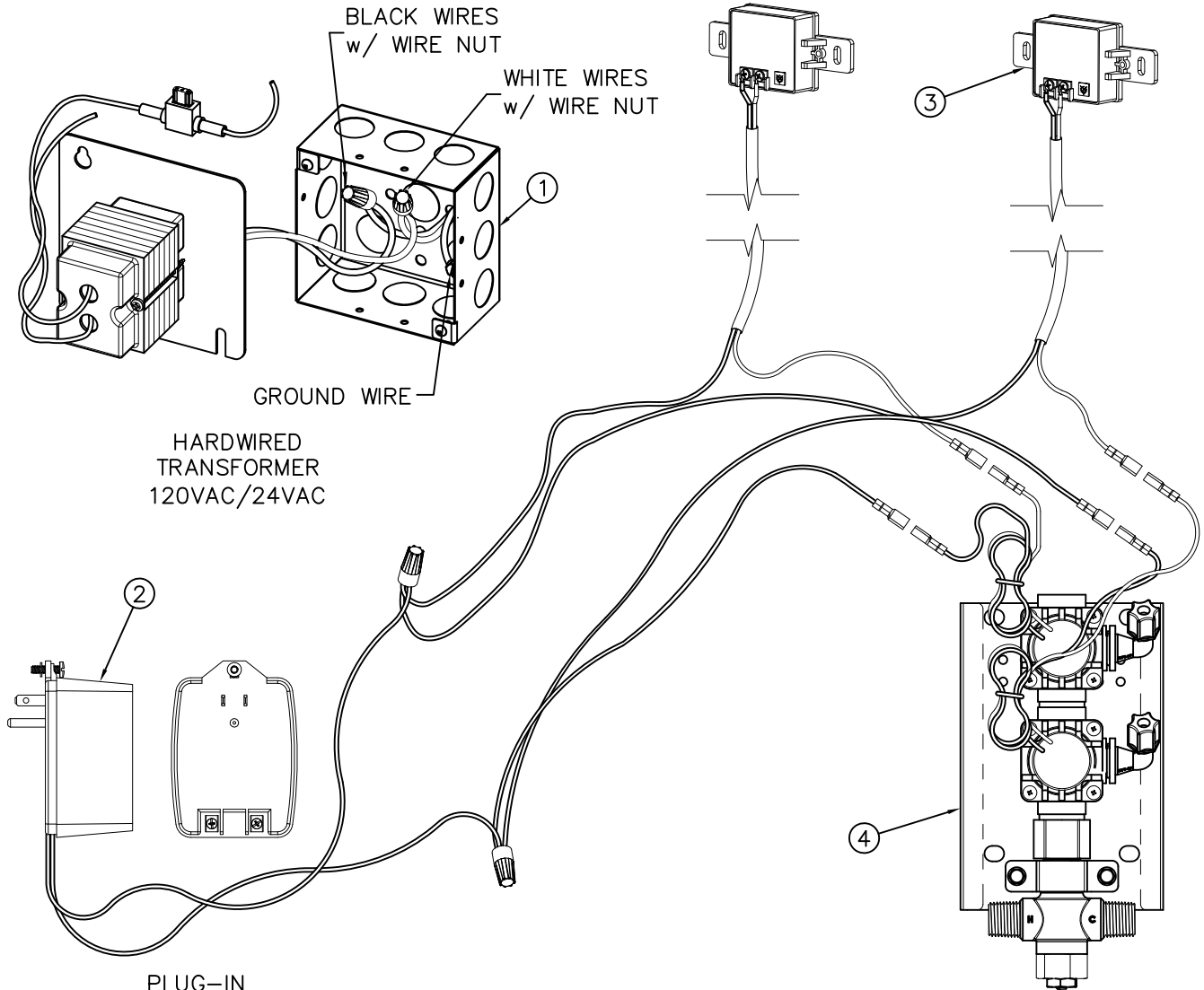

REFERENCE DRAWINGS	
24VAC SENSOR ADJUSTMENT	9940-011-001
24VAC SENSOR & HARDWARE	9955-015-002
24VAC SENSOR & MAINTENANCE	9940-010-002

INSTALLATION INSTRUCTIONS:

- A- REFER TO FIXTURE DRAWINGS FOR INSTALLATION & ROUGH-IN INFORMATION.
- B- PROVIDE 120VAC, 60Hz, 3 AMPS MAX, SERVICE TO CONNECT 24VAC, 50VA TRANSFORMER PLATE & J-BOX ①, OR RECEPTACLE FOR PLUG-IN TRANSFORMER ②. SEE NOTE.
- C- CONNECT WIRE SET FROM SENSOR ③ TO SOLENOID VALVE ④ AND TRANSFORMER ①, OR ②. CONNECT TRANSFORMER TO POWER SUPPLY.

- E- COMPLETE INSTALLATION OF FIXTURE PER FACTORY INSTALLATION SHEETS PROVIDED.

NOTE:

- 1- PLUG-IN TRANSFORMER INCLUDES BUILT-IN SECONDARY FUSE. IN THE EVENT OF POWER SURGE TRANSFORMER MAY REQUIRE REPLACEMENT.
- 2- ELECTRICAL RECEPTACLE MUST BE WIRED TO A GFI PROTECTED CIRCUIT. FIXTURE MUST BE EARTH GROUNDED PER N.E.C. (NATIONAL ELECTRICAL CODE).



ACORN ENGINEERING COMPANY
 P.O. BOX 3527 Industry, CA 91744
 15125 Proctor Ave Industry, CA 91746
 (626) 336-4561 FAX (626) 961-2200

TITLE 24VAC -SO SENSOR INSTALLATION INSTRUCTIONS		
MANUFACTURE DATE OCTOBER 2010 TO PRESENT	DATE ISSUED 05/10/10	DRAWING NUMBER 9912-531-003
	DATE REVISED 03/28/14 A	



NOTE: RANGE OF MOTION FOR ADJUSTMENT SCREW IS FROM APPROX. 8 O'CLOCK CLOCKWISE TO APPROX. 4 O'CLOCK.

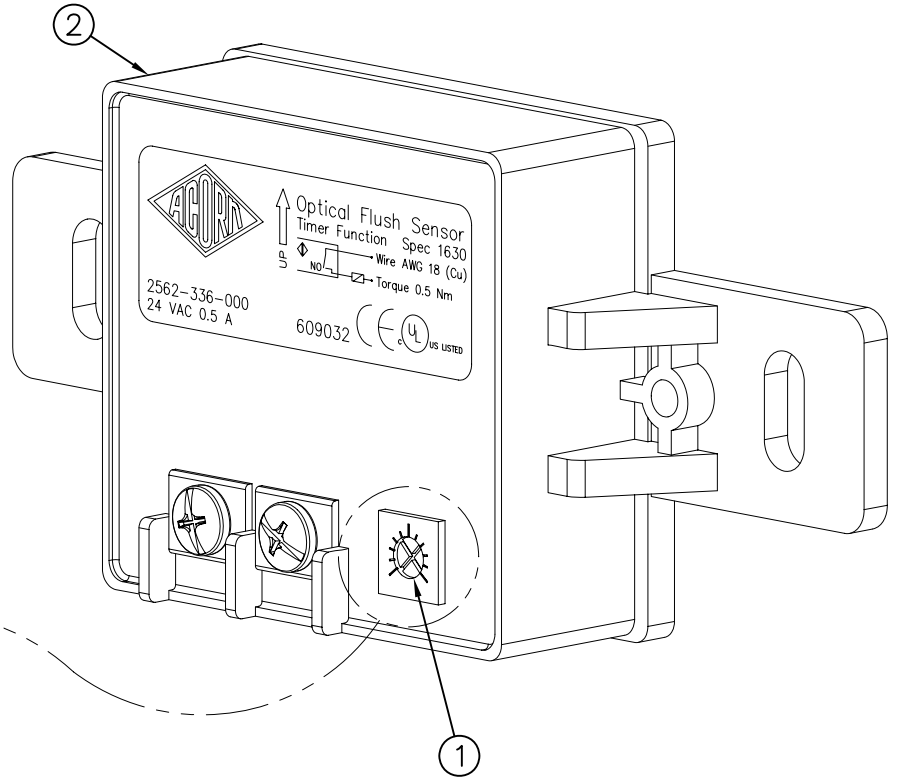

INCREASE

DECREASE

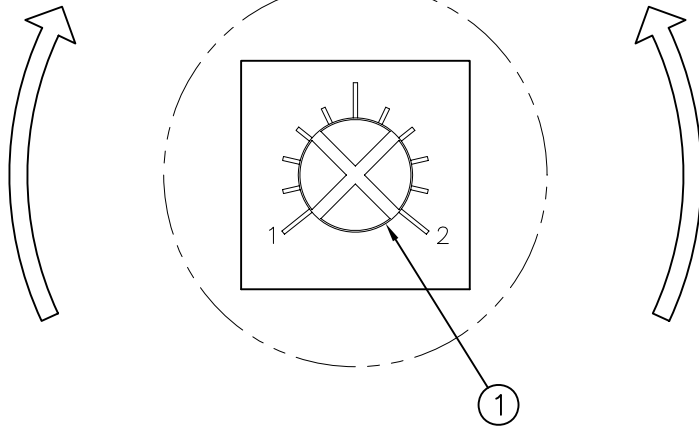

A- USE SMALL JEWELERS CROSS TIP SCREW DRIVER TO ADJUST SENSOR RANGE ① ON BACK OF SENSOR ②.

C- TURN ADJUSTMENT SCREW ① COUNTERCLOCKWISE TO DECREASE SENSOR RANGE.

B- TURN ADJUSTMENT SCREW ① CLOCKWISE TO INCREASE SENSOR RANGE.

D- NOTE: SENSOR RANGE IS FROM 0 TO APPROXIMATELY 24" MAXIMUM.



ACORN ENGINEERING COMPANY
P.O. BOX 3527 INDUSTRY, CA. 91744
(626) 336-4561 FAX (626) 961-2200

TITLE **24VAC SENSOR RANGE ADJUSTMENT**

MANUFACTURE DATE
**JUNE 2002
TO PRESENT**

DATE ISSUED
02/22/08
DATE REVISED
08/10/09

DRAWING NUMBER
9940-011-001



START UP MODE:

The Acorn -SO is a 24VAC sensor and includes a manual range adjustment. Sensor range adjustments may be made using adjustment screw on back of sensor.

The Start Up Mode will take approximately five (5) minutes to complete its full cycle and it is important that no target is present in front of the sensor during this time. A steady red light visible in the center of the oval sensor window indicates the sensor is in Start Up Mode. If the red light is flashing, this indicates that the sensor is picking up a target. Unless this target is a permanent fixture in the sensor's environment (i.e. a wall or stall door) it must be removed from the view of the sensor. If this target is permanent the sensor will attempt to adapt itself around this target. When Start Up Mode is complete the steady red light will go off.

NOTE:

1. If the 24VAC power supply is interrupted for more than fifteen (15) seconds the Start Up Mode will automatically repeat itself when the power is restored.
2. If the indicator light flashes three (3) times quickly, then three (3) times slowly and continues to repeat this sequence, this indicates incorrect wiring or a short in the 24VAC power supply.

NORMAL VALVE FUNCTION:

One second time delay when sensor is activated by user. Time of flow is 30 seconds. To reactivate, the user must move out of and return to the sensing area. When installed in the shower, flow continues indefinitely until user moves from sensing area.

CONDITION:	PROBABLE CAUSE
<p>NO WATER FLOW:</p>	<ol style="list-style-type: none"> 1.1 Stops or main water supply may be closed. 1.2 When using -T/P mixing valve, both supplies must be open to supply adequate water flow. 1.3 Clogged strainer. 1.4 Clogged water diaphragm. 1.5 Loose wiring connections. 1.6 Blown fuse at transformer. 1.7 Circuit breaker shut off.
<p>WATER WON'T SHUT OFF</p>	<ol style="list-style-type: none"> 2.1 Adjacent objects may be triggering the sensor. 2.2 Sensor malfunction.
<p>WATER DRIPS</p>	<ol style="list-style-type: none"> 3.1 Clogged water diaphragm.

MINIMUM / MAXIMUM WATER PRESSURE (PSI) 30 / 125. MAXIMUM WATER TEMPERATURE 130°F.

Refer to drawing #9955-016-002 for parts breakdown of items listed above.

Refer to Acorn Operations And Maintenance Manual for installation instructions and repair parts.

<p>ACORN ENGINEERING COMPANY P.O. BOX 3527 Industry, CA 91744 15125 Proctor Ave Industry, CA 91746 (626) 336-4561 FAX (626) 961-2200</p>	TITLE		
	24VAC -SO SENSOR OPERATED VALVE MAINTENANCE INSTRUCTIONS		
	MANUFACTURE DATE	DATE ISSUED	DRAWING NUMBER
FEBRUARY 2012	02/09/12	9940-010-003	
TO PRESENT	DATE REVISED		



TWO STATION WIRING DIAGRAM SHOWN

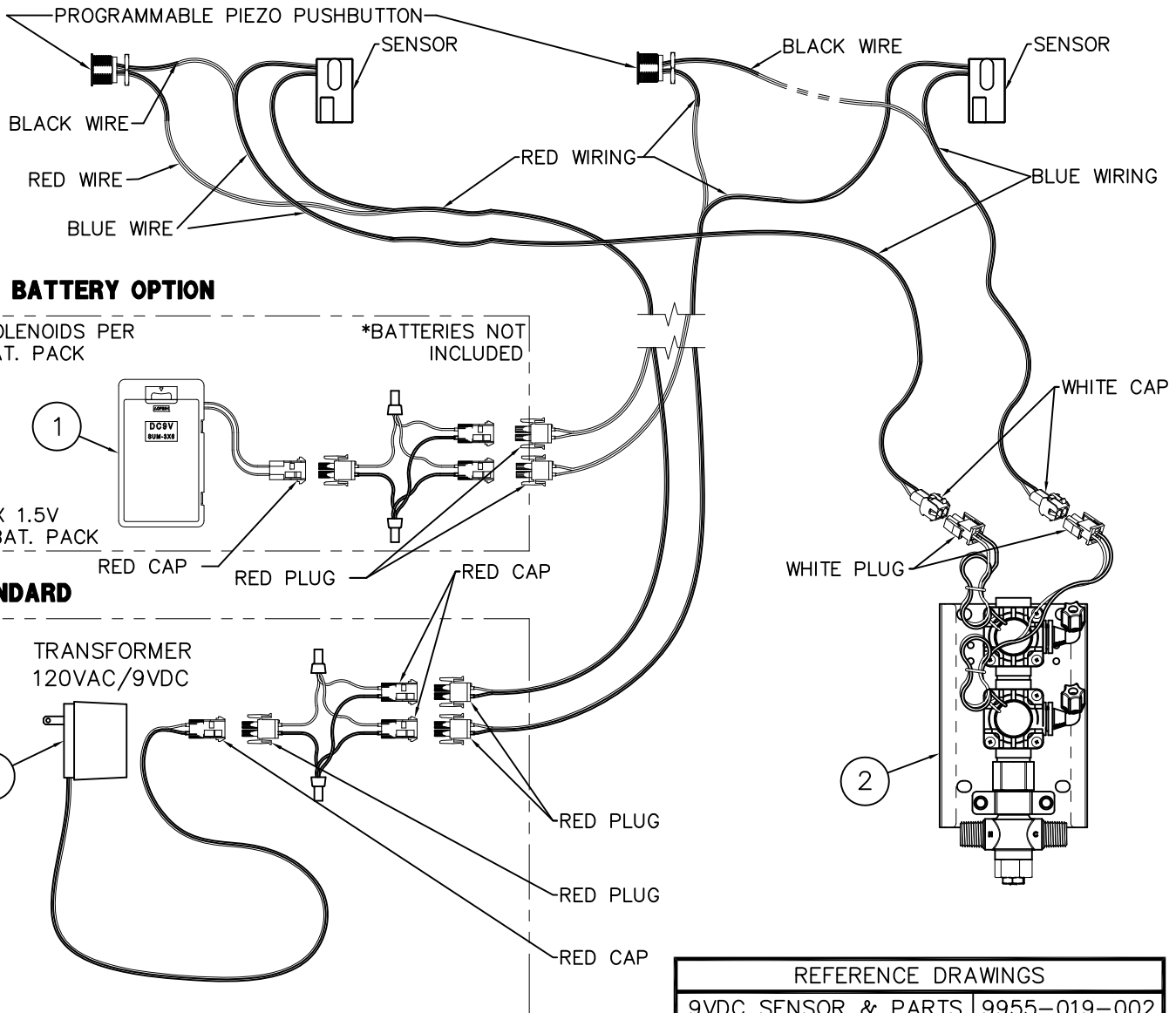

-BAT BATTERY OPTION

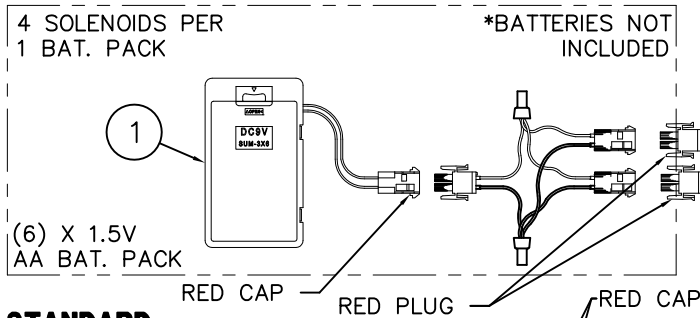

STANDARD

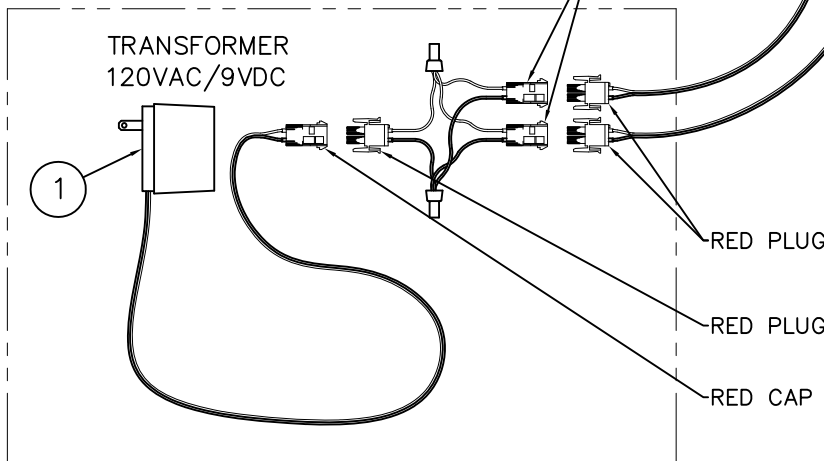

REFERENCE DRAWINGS	
9VDC SENSOR & PARTS	9955-019-002
PIEZO PB PROGRAMMING	9940-009-001

INSTALLATION INSTRUCTIONS:

- A- USING APPROPRIATE INSTALLATION INSTRUCTIONS, MOUNT FIXTURE TO WALL AND MAKE-UP WASTE PIPING CONNECTIONS. SENSOR OR ELECTRONIC PUSHBUTTON ARE FACTORY INSTALLED. POWER SUPPLY ① AND VALVE ② SHIPPED LOOSE.
- B- INSTALL SOLENOID VALVE ASSEMBLY ② ON THE WALL (FASTENERS AND WALL ANCHORS BY OTHERS), MAKING SURE THAT THE VALVE WILL BE WITHIN BOTTOM ENCLOSURE.
- C- CONNECT WATER SUPPLY (AFTER FLUSHING LINES) TO VALVE, AND VALVE RISER TO SPOUTS AS PER UNIT INSTALLATION INSTRUCTIONS.

- D- CONNECT SOLENOID VALVE, POWER SUPPLY AND SENSOR WIRING AS SHOWN ON DETAIL.
- E- COMPLETE THE INSTALLATION OF THE UNIT ACCORDING TO THE UNITS INSTALLATION INSTRUCTIONS.

NOTE:

- 1- PLUG-IN TRANSFORMER INCLUDES BUILT-IN SECONDARY FUSE. IN THE EVENT OF POWER SURGE TRANSFORMER MAY REQUIRE REPLACEMENT.
- 2- ELECTRICAL RECEPTACLE MUST BE WIRED TO A GFI PROTECTED CIRCUIT. FIXTURE MUST BE EARTH GROUNDED PER N.E.C. (NATIONAL ELECTRICAL CODE).

<p>ACORN ENGINEERING COMPANY P.O. BOX 3527 Industry, CA 91744 15125 Proctor Ave Industry, CA 91746 (626) 336-4561 FAX (626) 961-2200</p>	<p>TITLE -SO SENSOR/ -PPZ PIEZO ELECTRONIC PUSHBUTTON INSTALLATION</p>		
	<p>MANUFACTURE DATE</p> <p>OCTOBER 2009</p> <p>TO PRESENT</p>	<p>DATE ISSUED</p> <p>09/06/13</p>	<p>DRAWING NUMBER</p> <p>9927-221-005</p>
		<p>DATE REVISED</p> <p>03/25/14</p>	

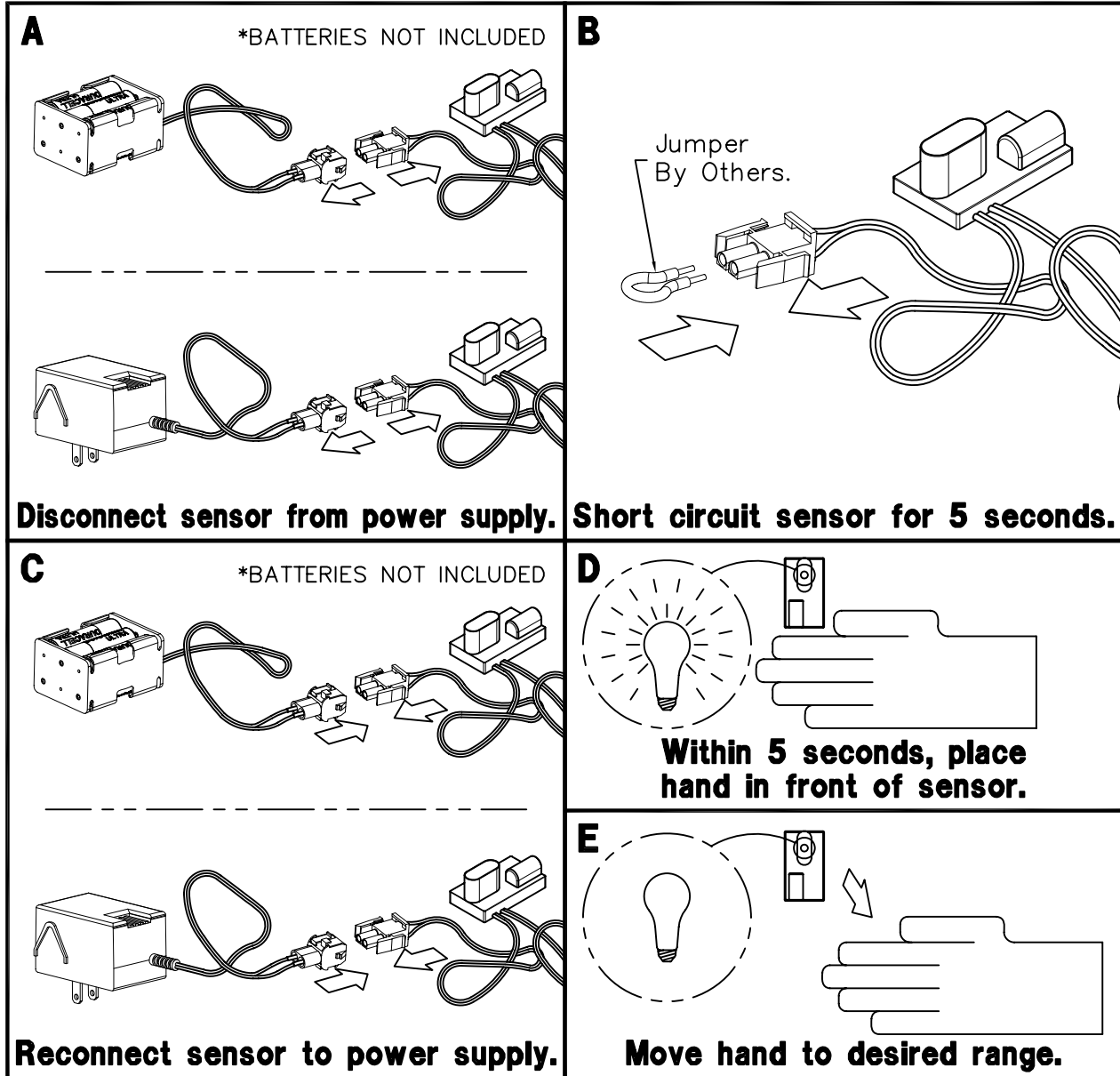

NOTE: THESE INSTRUCTIONS ONLY APPLY TO 9 VOLT SENSORS THAT DO NOT HAVE A RANGE ADJUSTMENT SCREW ON THE BACK. SEE DRAWING # 9927-222-001.

INSTRUCTIONS:

- A- Disconnect sensor from power supply.
- B- Create a short circuit between the positive and negative connections on the sensor for five seconds. **WARNING:** Do not create a short circuit on the power supply or while the sensor is connected to the power supply.
- C- Reconnect the sensor to the power supply.

- D- Within 5 seconds of making the connection, place hand 2 to 4 inches from the sensor.
- E- Once red light begins flashing quickly, move hand to preferred distance and wait for light to stop flashing.
- F- Check distance. If unsatisfactory, repeat steps A through E.

<p>ACORN ENGINEERING COMPANY P.O. BOX 3527 INDUSTRY, CA. 91744 (626) 336-4561 FAX (626) 961-2200</p>	<p>TITLE 9 VOLT DC SENSOR RANGE ADJUSTMENT</p>		
	<p>MANUFACTURE DATE</p> <p>SEPTEMBER, 2001 TO PRESENT</p>	<p>DATE ISSUED</p> <p>09/06/01</p> <hr/> <p>DATE REVISED</p> <p>09/30/11</p>	<p>DRAWING NUMBER</p> <p>9927-222-002</p>



Programable Piezo Pushbutton Programming Instructions (Flow Time Adjustment)

The Button is factory set an 8 sec. timing cycle, if an 8 sec. cycle is adequate, then **no** programming adjustment is required.



NOTE: Read the entire document before trying to program the piezo pushbutton.

THE TIME SETTINGS PROGRAM USES 3 DIFFERENT TIMING MODES:

- **1 second timing mode:** Each push of the button adds 1 second to the total timing cycle.
- **5 second timing mode:** Each push of the button adds 5 seconds to the total timing cycle.
- **20 second timing mode:** Each push of the button adds 20 seconds to the total timing cycle.

To program the piezo pushbutton, you will need to be able to see the back of the piezo pushbutton.

Prevision must be made to access the back of the piezo pushbutton. There is an LED on the back of the piezo pushbutton under a layer of transparent epoxy, used as a programming indicator light.



NOTE: This programming procedure moves along rapidly, there is only about 2 or 3 seconds between programming operations.

In order to start the programming the piezo pushbutton, the button must be powered down. Disconnect the red power cable and wait 20 seconds, then reconnect the red power cable.

As soon as the cable is reconnected the LED will start flashing, it will flash 4 times, then stays on for 3 seconds. During the 3 second period, push the piezo button once, the LED will go out, now you are in the **1 sec timing mode** and each time the button is pushed the LED will flash, adding 1 sec to the total timing cycle.

To move on to the **5 sec timing mode**, pause and wait for the LED to flash 2 times, now you are in the 5 sec timing mode. Each time the button is pushed the LED will flash, adding 5 sec to the total timing cycle.

To move on to the **20 sec timing mode**, pause and wait for the LED to flash 3 times, now you are in the 20 sec timing mode and each time the button is pushed the LED will flash, adding 20 sec to the total timing cycle. After programing is complete, pause and wait for the LED to flash 4 times and then 5 times, which completes the programming.

- When a **timing mode is not required** then **do not** push the button and wait for the next timing mode.
- Each timing mode (1 sec, 5 sec or 20 sec timing mode) can be sequenced up to 100 times, that is the number of times, the button can be pushed, to increase the total timing cycle in each timing mode.



Please visit www.acorneng.com for most current specifications.

Programmable Piezo Pushbutton Programming Instructions (Flow Time Adjustment)

WORKSHEET

(FILL IN ALL BOXES, WHICH WILL SIMPLIFY THE PROGRAMMING PROCEDURE)

Fill in all the Boxes below
↓ ↓

Determine the number of seconds per timing cycle
□

1 Push = 1 Second
□ x 1 = □ sec



- PROGRAMING STEPS:**
- Power down piezo button for 10 seconds.
 - Reconnect power.
 - LED flashes, then stay on.
 - While the LED is steady on, push button.
 - LED turns off.
 - You are in the 1 sec timing mode, immediately push the button, 1 push equals 1 sec added to the total timing cycle.
 - Pause and wait for the LED to flash 2 times.

ADD ↑↓

1 Push = 5 Seconds
□ x 5 = □ sec



- You are in the 5 sec timing mode, immediately push the button, 1 push equals 5 sec added to the total timing cycle.
- Pause and wait for the LED to flash 3 times.

ADD ↑↓

1 Push = 20 Seconds
□ x 20 = □ sec



- You are in the 20 sec timing mode, immediately push the button, 1 push equals 20 sec added to the total timing cycle.

EQUALS ↓

Total timing cycle equals
□ seconds



INSTALLATION, OPERATIONS & MAINTENANCE MANUAL

Please visit www.acorneng.com
for most current specifications.

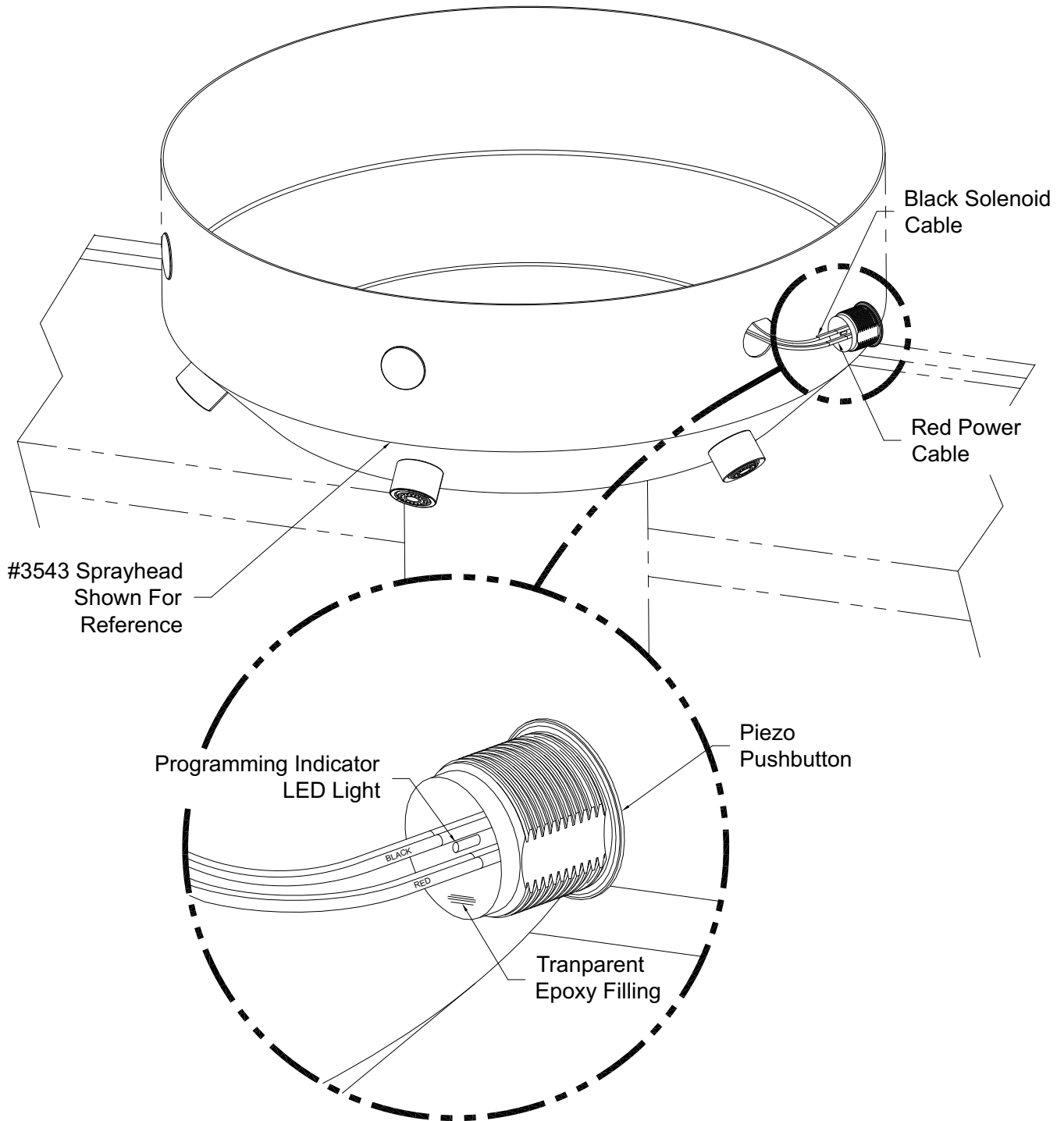

Part #: 9940-009-001

New: 10/01/13

ACORN ENGINEERING COMPANY

ACORN ENGINEERING FIELD SERVICE
TOLL FREE 800-743-8259 • LOCAL 626-855-4866 • FAX 626-855-4863