



**AIR CONDITIONING PRODUCTS CO.**  
QUALITY PRODUCTS FOR AIR MOVEMENT EQUIPMENT

# EXTRUDED ALUMINUM DRAINABLE BLADE STATIONARY LOUVER

## MODEL DFL

Heavy duty Extruded Aluminum construction designed to protect the air intake and exhaust openings in the exterior walls of any building from rain and weather while still providing efficient airflow. The drainable blade design provides the best protection against water entering the opening by channeling water away from the blades and down the jambs. This eliminates water cascading from blade to blade. Aluminum finish is ready for you to paint in the field or leave as mill finish.

### STANDARD CONSTRUCTION:

#### FRAME

- 4" deep channel x .080" thick Extruded Aluminum.

#### BLADES

- Drainable style, .080" thick Extruded Aluminum, positioned at a 45 degree angle and spaced approximately 4" centers.

#### CONSTRUCTION

- Screwed.

#### BIRDSCREEN

- 1/2" Flattened Aluminum in a removable frame mounted on the interior.

#### FINISH

- Mill.

#### MINIMUM SIZE

- 12" W x 12" H

#### MAXIMUM SINGLE SECTION SIZE

- 60" W x 96" H

#### OPTIONS (AT ADDITIONAL COST)

- 1-1/2" Flange

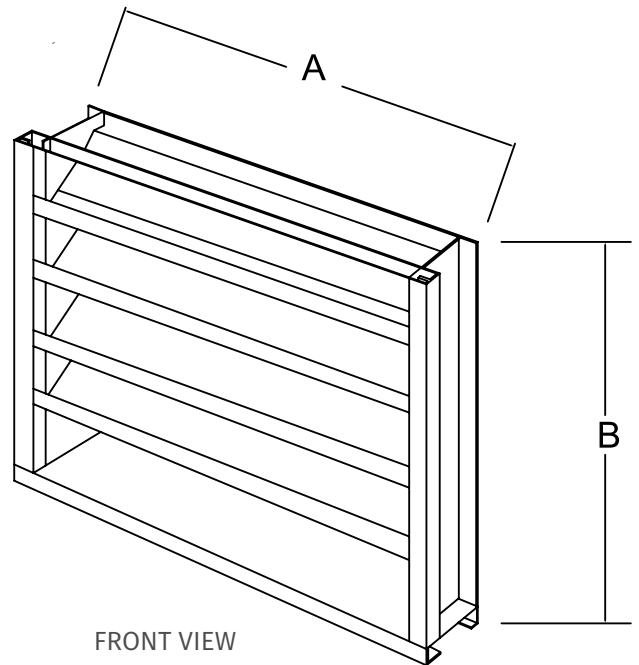

FRONT VIEW

Note: Above "A" and "B" dimensions are undersized by 1/2" + or - normal tolerance of .0625".

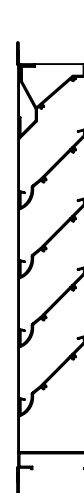

SIDE VIEW  
FLANGED FRAME

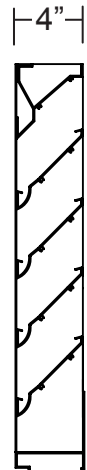

SIDE VIEW  
CHANNEL FRAME

Air Conditioning Products Company certifies that the DFL louvers shown herein are licensed to bear the AMCA Seal. The ratings shown are based on tests and procedures performed in accordance with AMCA Publication 511 and comply with the requirements of the AMCA Certified Ratings Program. The AMCA Certified Ratings Seal applies to Air Performance and Water Penetration ratings.

# MODEL DFL

## FREE AREA CHART (SQ. FT.):

		LOUVER WIDTH IN INCHES							
		18	24	30	36	42	<b>48</b>	54	60
LOUVER HEIGHT IN INCHES	18	1.00	1.40	1.81	2.21	2.61	3.01	3.41	3.81
	24	1.25	1.76	2.26	2.76	3.26	3.76	4.26	4.76
	30	1.76	2.46	3.16	3.86	4.56	5.26	5.97	6.67
	36	2.01	2.81	3.61	4.41	5.21	6.02	6.82	7.62
	42	2.51	3.51	4.51	5.51	6.52	7.52	8.52	9.53
	<b>48</b>	2.76	3.86	4.96	6.07	7.17	<b>8.37</b>	9.37	10.48
	54	3.26	4.56	5.87	7.17	8.47	9.78	11.08	12.38
	60	3.51	4.91	6.32	7.72	9.12	10.53	11.93	13.34
	66	4.01	5.62	7.22	8.82	10.43	12.03	13.64	15.24
	72	4.26	5.97	7.67	9.37	11.08	12.78	14.49	16.19
	78	4.76	6.67	8.57	10.48	12.38	14.29	16.19	18.10
	84	5.01	7.02	9.02	11.03	13.03	15.04	17.04	19.05
	90	5.51	7.72	9.93	12.13	14.34	16.54	18.75	20.95
96	5.77	8.07	10.38	12.68	14.99	17.30	19.60	21.91	

### PRESSURE DROP

Standard Air - .075 lbs per cubic foot  
Test size - 48" x 48" (Intake)

Ratings do not include the effect of a birdscreen

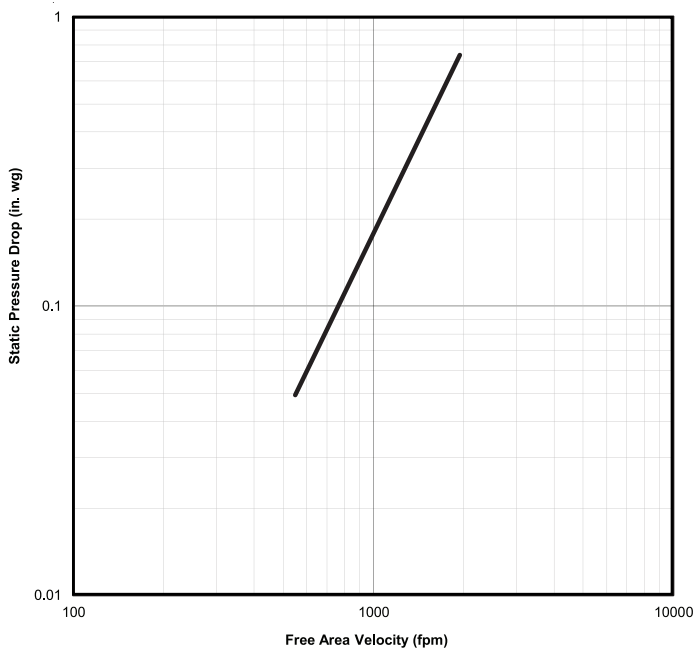

### WATER PENETRATION

Standard Air - .075 lbs per cubic foot  
Test size - 48" x 48" for a 15 minute duration

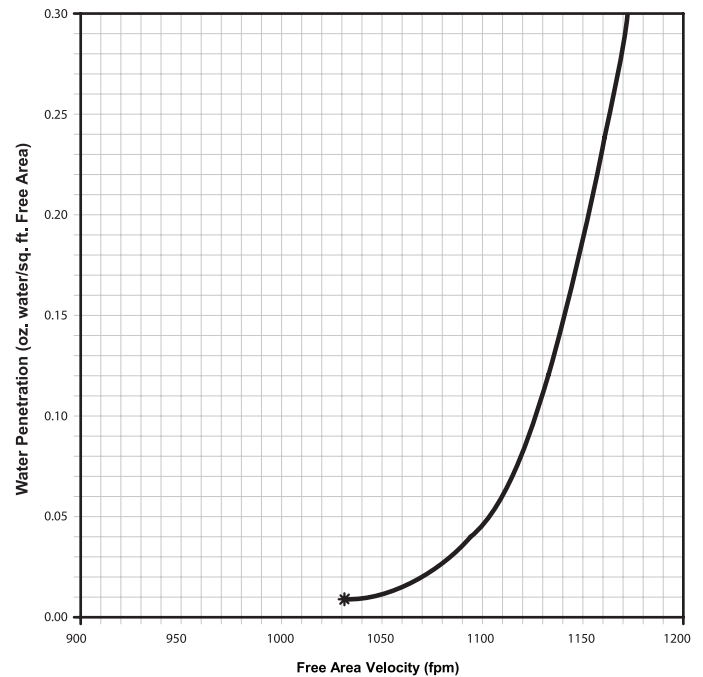

The beginning point of water penetration at .01 oz./sq. ft. is 1031 fpm free area velocity.

AMCA Standard 500-L provides a method for testing and rating louvers. These tests were performed under certain sets of laboratory conditions. These performance ratings do not guarantee that other environmental conditions may actually occur. Use safety factors when selecting louver sizes based upon performance.

For detailed information on our Limited Warranty Policy, please visit [www.acpshutters.com](http://www.acpshutters.com), or call (734) 326-0050.