

EFFECTIVE:
24-AUG-17

SUPERSEDES:
NEW

DIMENSION PRINT
WORLD MOTOR HOSTILE DUTY
FRAME: 213T, 215T
BASIC TYPE: CT

PRINT:
08-1019

SHEET:
1 OF 1

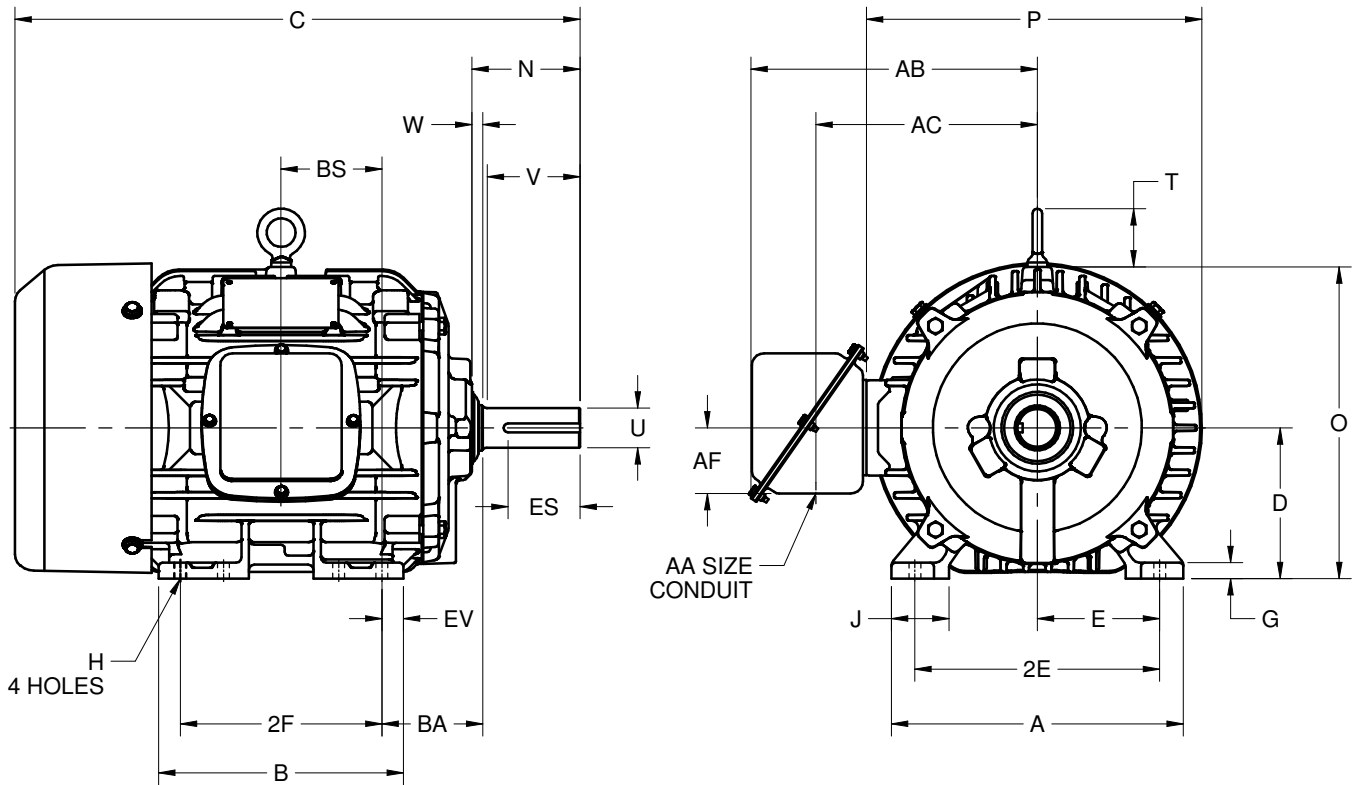

ALL DIMENSIONS ARE IN INCHES AND MILLIMETERS

UNITS	A	B	C	D -.06	E	2E ±.03	G	H +.05	J	K	N	O	P ²
IN	10.13	8.50	19.63	5.25	4.25	8.50	.56	.41	2.00	3.13	3.75	10.84	11.66
MM	257	216	499	133	108	216	14	10	51	80	95	275	296

UNITS	T	U -.001	V MIN	W	AA	AB	AC	AF	BA	BS	EV	ES MIN	SQ KEY
IN	2.03	1.3750	3.12	.38	1.00	9.94	7.69	2.28	3.50	3.50	.75	2.41	.312
MM	52	34.925	79	10		252	195	58	89	89	19	61	7.92

FRAME	UNITS	2F ±.03
213T	IN	5.50
	MM	140
215T	IN	7.00
	MM	179

1. DIMENSIONS MAY VARY .25" DUE TO CASTING AND/OR FABRICATION VARIATIONS
2. LARGEST MOTOR WIDTH
3. STANDARD ASSEMBLY POSITION F-1 IS SHOWN. F-2 IS PROVIDED WHEN SPECIFIED. CONDUIT OPENING MAY BE LOCATED IN STEPS OF 90° REGARDLESS OF THE LOCATION
4. TOLERANCES ARE SHOWN IN INCHES ONLY

08-1019/-

Nidec Motor Corporation
St. Louis, Missouri

INFORMATION DISCLOSED ON THIS DOCUMENT IS CONSIDERED PROPRIETARY AND SHALL NOT BE REPRODUCED OR DISCLOSED WITHOUT WRITTEN CONSENT OF NIDEC MOTOR CORPORATION



ISSUED BY
R. TIMMERMANN
APPROVED BY
M. CULLEN

IHP_DP_NMCA (MAR-2011) SOLIDEDGE