

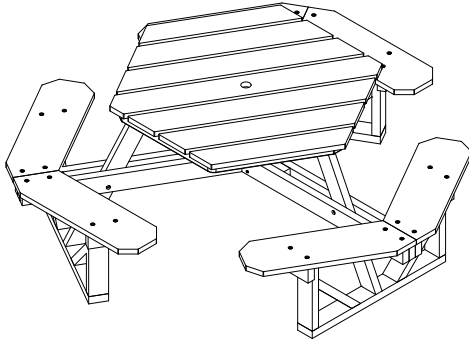



Assembly Instructions

Customer Service
 US: 1-800-645-2986

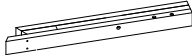
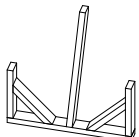
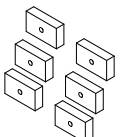
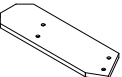

CONTENTS					
Ref.	Qty.	Description	Ref.	Qty.	Description
1	1	Pre-Assembled Top 	4	3	Support Arms 
2	3	Base Supports 	5	6	Anchor Blocks 
3	3	Left Seats  Right Seats 	H1	1	Hardware Pack* 

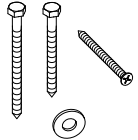
*Contains: (6) 2 1/2" Hex Lag Screws
 (30) 3 1/2" Hex Lag Screws
 (36) Flat Washers
 (9) 3" Deck Screws

Before you begin: Check components to verify all are included. Assembly requires two people and must be performed on a flat and even surface. Do not overtighten hardware as damage can occur.

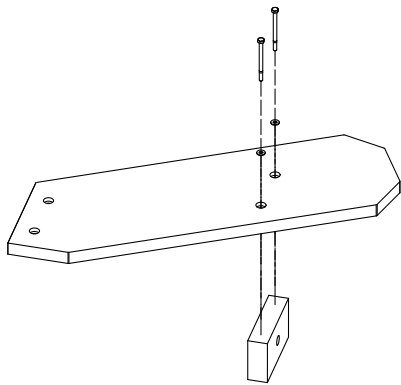

Step 1

Secure anchor blocks to the bottom of each seat using 3 1/2" hex lag screws and flat washers. The pre-drilled hole in the block will face the seat side with three edges. Each seat will have one (1) anchor block.

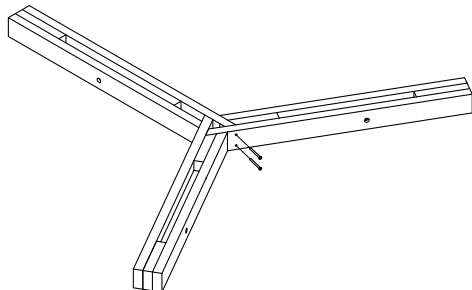

Step 2

Place the three (3) support arms on a flat surface. Fasten the support arms together with 3" deck screws, two (2) per side. Do not overtighten.

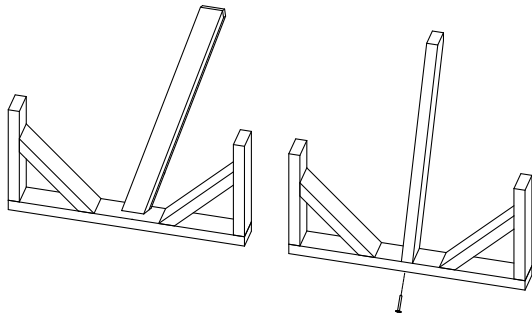

Step 3

The three (3) base support legs are rotated for shipping purposes. A single deck screw is pre-installed, rotate the leg 90 degrees and align the pre-drilled holes. Secure the leg with a supplied deck screw. Repeat for all three (3) legs.

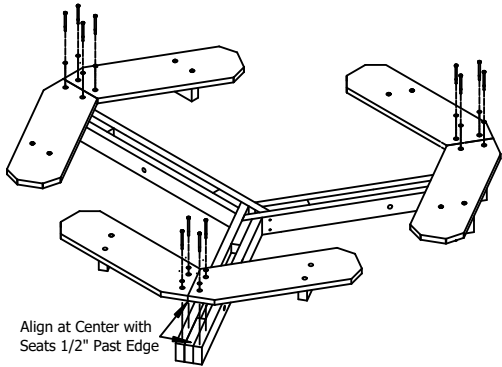

Step 4

With the assembled support arms on a flat surface, position a LH and RH seat with the flat edges aligned at the center point of the middle board of the arm assembly. The back edge of the seats should extend approximately 1/2" from the back edge of the arm support. See Illustration. Drill a small starter hole in the support arms at each pre-drilled hole of the seats. Attach using 3-1/2" hex lag screws and flat washers. Repeat for remaining seats.

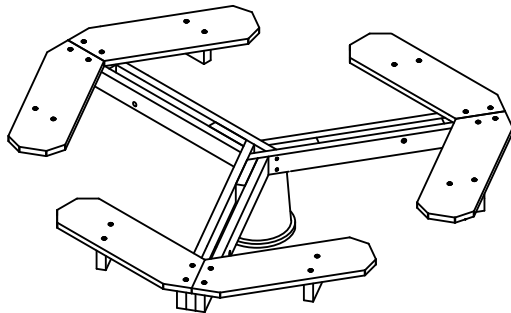

Step 5

Using two people, raise the arms and seats up to rest on an object strong enough to support the assembly at the mid point approximately 12" above the mounting surface. A five gallon bucket can be used in this step.

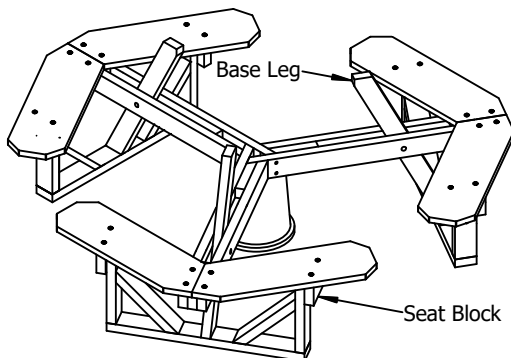

IMPORTANT NOTE FOR THE NEXT STEPS: DO NOT OVERTIGHTEN LAG BOLTS. DO NOT LEAN ON TABLE TOP OR SEATS WHEN ASSEMBLING.

Step 6

Insert a base leg inside an arm support with the pre-drilled hole in arm aligned on the base leg. The seat blocks previously attached in step 1 should rest against the outer side of the base seat supports.

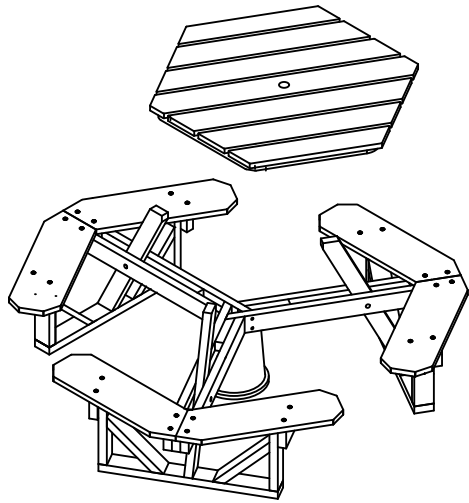

Step 7

With two people, carefully lift the table top and position the slots in the top underside frame with the three (3) base legs, slide the top down on the legs. Ensure each base leg is fully engaged in the slot and the top is resting even and level.

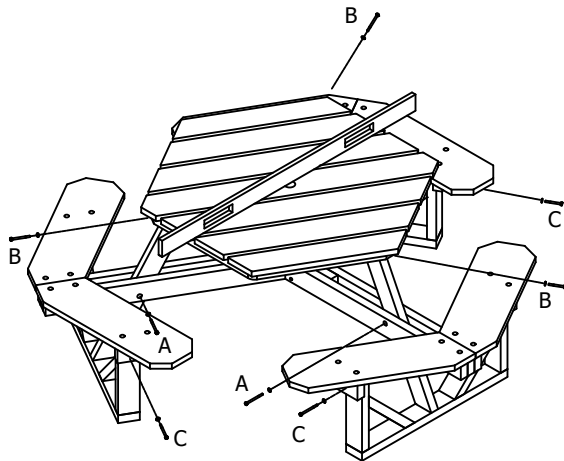

Step 8

Remove the item used to support the arm assembly to allow for proper positioning. Ensure the bases are resting flat on the mounting surface, position the horizontal arm with the pre-drilled hole in line with the base leg. The distance between the bottom side of each support arm and the mounting surface should be the same. Attach each arm to a base leg using a 3 1/2" hex lag screw and flat washer (A).

Verify the top is level, attach top to the vertical supports with 3 1/2" hex lag screws and flat washers (B).

Attach the seat blocks to each base seat support using 2 1/2" hex lag screws and flat washers (C). See Illustration 'H'.

Cleaning Tips:

Clean using a mild dish soap and warm water. Apply the soapy mixture to a clean cloth and scrub away the dirt. Rinse with clean water. If you have stubborn dirt inside the grooves and divots, mix 1 part bleach to 2 parts water, and wipe using a clean cloth. If needed, scrub with a soft bristle brush and then rinse.