

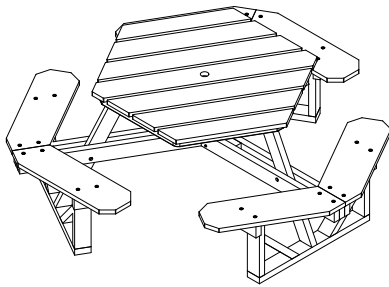



Assembly Instructions

Customer Service  
US: 1-800-645-2986

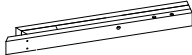
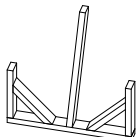
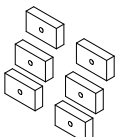
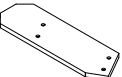

CONTENTS					
Ref.	Qty.	Description	Ref.	Qty.	Description
1	1	Pre-Assembled Top 	4	3	Support Arms 
2	3	Base Supports 	5	6	Anchor Blocks 
3	3	Left Seats  Right Seats 	H1	1	Hardware Pack* 

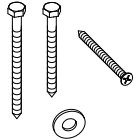
\*Contains: (6) 2 1/2" Hex Lag Screws  
(30) 3 1/2" Hex Lag Screws  
(36) Flat Washers  
(9) 3" Deck Screws

Before you begin: Check components to verify all are included. Assembly requires two people and must be performed on a flat and even surface. Do not overtighten hardware as damage can occur.

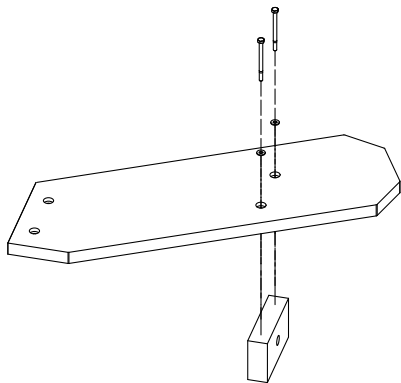

Step 1

Secure anchor blocks to the bottom of each seat using 3 1/2" hex lag screws and flat washers. The pre-drilled hole in the block will face the seat side with three edges. Each seat will have one (1) anchor block.

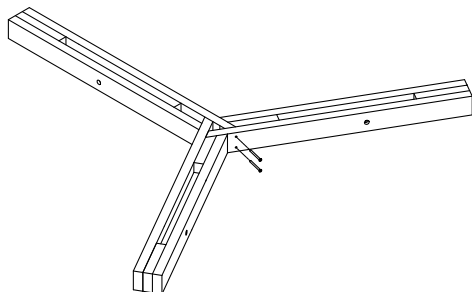

Step 2

Place the three (3) support arms on a flat surface. Fasten the support arms together with 3" deck screws, two (2) per side. Do not overtighten.

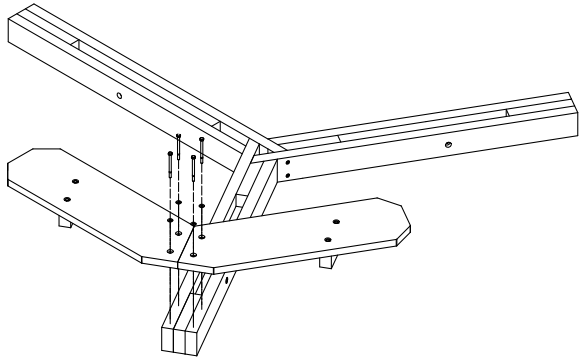

**Step 3**

Align the pre-drilled holes in the seats and support arms, attach using 3 1/2" hex lag screws and flat washers.  
Installation Tip: Seats may fit tightly side by side, tilt the seats up slightly as you tighten lag screws to pull them down flush against the support arms.

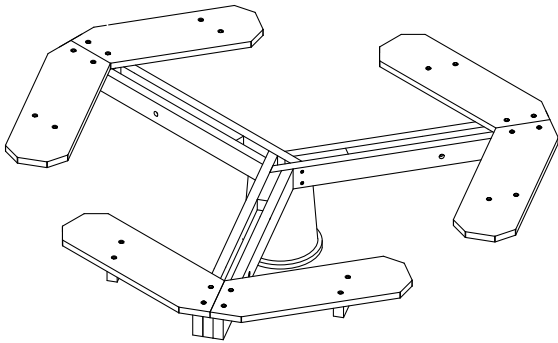

**Step 4**

Position the assembled seats and support arms assembly approximately 10" to 15" above the floor. Tip: A five gallon bucket under the center point of the assembly works well.

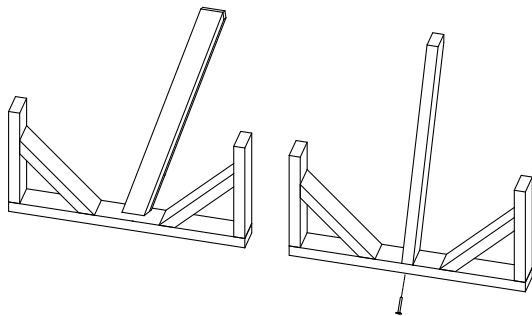

**Step 5**

The three (3) base support legs are rotated for shipping purposes. A single deck screw is pre-installed, rotate the leg 90 degrees and align the pre-drilled holes. Secure the leg with a supplied deck screw. Repeat for all three (3) legs.

**IMPORTANT NOTE FOR THE NEXT STEPS: DO NOT OVERTIGHTEN LAG BOLTS. DO NOT LEAN ON TABLE TOP OR SEATS WHEN ASSEMBLING.**

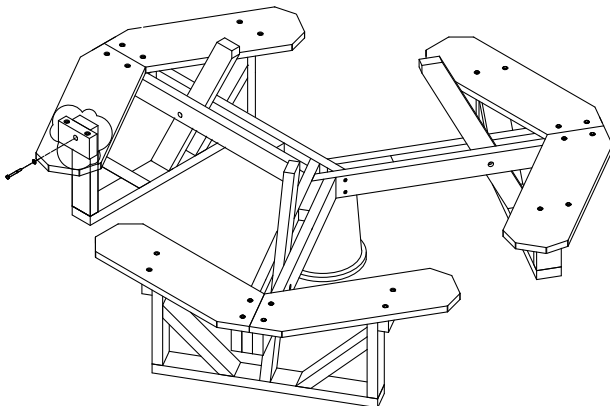

**Step 6**

Insert a base support in the open space of each of the three (3) support arms, centering each leg on the pre-drilled countersunk holes of the support arms. Attach the base support uprights to the seat blocks with 2 1/2" hex lag screws and flat washers. Ensure the seats are centered with the support arms.

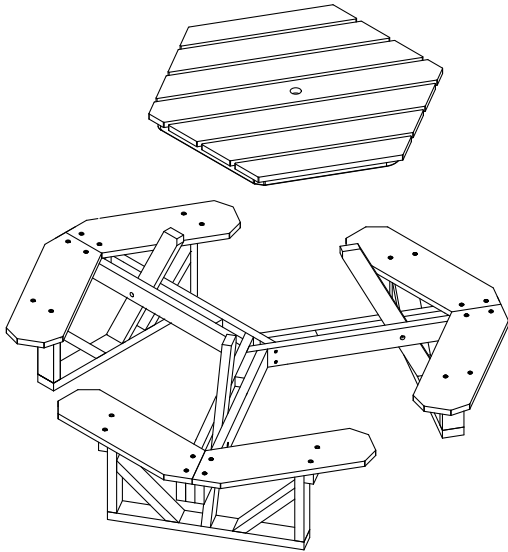

Step 7

With two people, carefully lift the table top and position the slots in the top underside frame with the three (3) uprights. Slide the top down onto the uprights. Ensure each upright is fully engaged in the slot and the top is resting even and level.

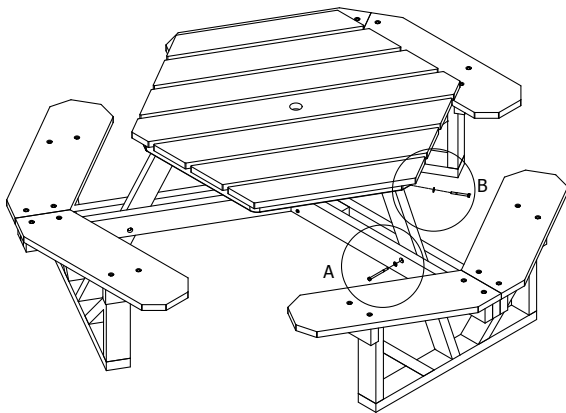

Step 8

Attach each upright to the table top using a 3 1/2" hex lag screw and flat washer, tighten fully. Hex head should be within the countersunk hole. Attach all three (3) support arms to the base uprights at the pre-drilled holes using a 3 1/2" hex lag screw and flat washer.

