



Model # G3415 1/4" Right Angle Die Grinder

Operating Instructions, Parts List, Warranty, & Warranty Repair Center

IMPORTANT! Read carefully before operating this tool. Failure to operate any power tool properly can result in personal injury and/or property damage!

Free Speed (RPM)	18,000	Collet Size	1/4"
Air pressure (PSI)90	Avg. Air Consump.(cfm).....	4
Hose Size (ID)	3/8"	Overall Length	6-1/8"
Air Inlet (NPT)	1/4"	Weight (Lbs)	1

Safety

1. Make sure the RPM rating of the grinding stones corresponds with the manufacturer's recommended speed of the tool.
2. Always wear approved eye protection.
3. Have throttle in "off" position when connecting to air supply.
4. Disconnect tool before performing service, changing accessories, or when not in use.
5. Always be in a safe working distance from others when using tools.
6. Keep tools clean and oiled for best and safest performance.
7. Follow instructions for lubricating and changing accessories.
8. Do not wear loose fitting clothing and remove watches and rings.
9. Always use proper hose and fittings. Never use quick change couplings attached at tool.
10. Keep proper footing and balance at all times.
11. Never carry tools by the hose. Keep hoses from heat, oil, and sharp edges. Check hoses for weak or worn condition before each use, making certain that all connections are secure.

Lubrication

Lubricate the tool daily with a good grade of air tool oil. The oil can be applied directly into the air inlet of the tool and then run the tool. A rust inhibitor oil is acceptable for air tools.

Air Supply

Tools of this class operate on a wide range of air pressure. It is recommended that air pressure of these tools measure 90 PSI at the tool while running free. Higher pressure and unclean air will shorten the tool's life and may create a hazardous condition.

Water in the airline will cause damage to the tool. Ensure that the air tank is drained daily. Clean the air inlet filter screen on at least a weekly basis. The recommended hookup procedure can be viewed in the illustration below.

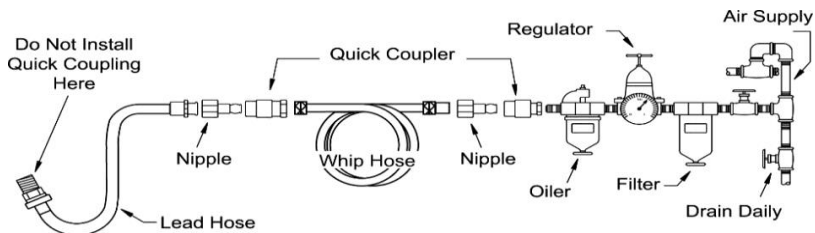

The air inlet, used for connecting air supply, has standard 1/4" NPT American Thread.

Line pressure should be increased to compensate for unusually long air hoses (over 25 feet). Minimum hose diameter should be 1/4" I.D. and fittings should have the same inside dimensions.

Operating Instructions

The air regulator can be used as an air throttle for setting positive speed control. Turn the air regulator lever up for maximum speed.

The air inlet used for connecting air supply has standard 1/4" NPT thread. Have throttle in "off" position when connecting to air supply. Disconnect tool before performing service, changing accessories and when not in use. Always use tool at a safe distance from other people in the work area.

WARNING: Make sure the RPM rating of the grinding discs correspond with the manufacturer's recommended speed of the tool.

Maintenance

Other factors outside the tool may cause loss of power or erratic action. Reduced Compressor output, excessive drain on the air line, moisture or restriction in air lines or the use of hose connections of improper size or poor condition may reduce air supply. Dirt or gum deposits in the tool may cut power. This may be corrected by cleaning the air strainer and flushing out the tool with gum solvent oil. If outside conditions are in order and tool is out-of-warranty, clean, reassemble, and re-lubricate, or take tool to any air tool service center. For tools in warranty period, send tool direct to Warranty Center.

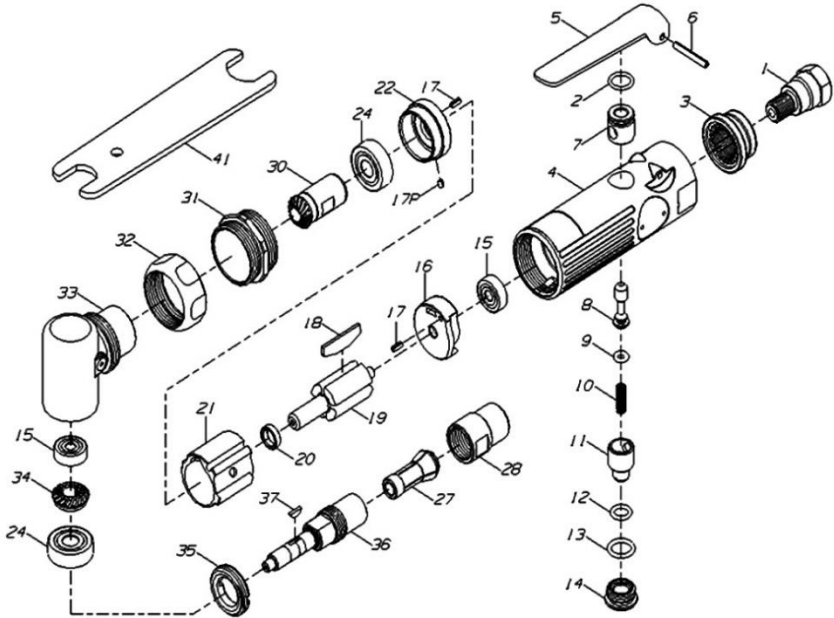

No.	Part No.	Description	No.	Part No.	Description
1	103401	Inlet Bushing	17P	P-0025-030	Pin
2	O-0950-150	O-Ring	18	103418	Rotor Blades (4)
3	103403	Exhaust Sleeve	19	103419	Rotor
	103403-B	Exhaust Washer	20	103420	Bearing Spacer
4	103404	Motor Housing	21	103421	Cylinder
5	103127-3	Safety Lever	22	103422	Front End Plate
6	P-0030-220	Throttle Lever Pin	24	0608-ZZ0A	Ball Bearing (2)
7	103407	Valve Bushing	27	103104	Collet(1/4", 1/8", 6mm, 3mm)
8	103408	Throttle Valve	28	103428	Collet Nut
9	O-0380-190	O-Ring	30	103630	Bevel Gear
10	103410	Spring	31	103631	Cap Lock
11	103411	Air Regulator	32	103632	Threaded Cap
12	O-0700-180	O-Ring	33	103633	Angle Housing
13	O-0980-190	O-Ring	34	103634	Bevel Gear
14	103414	Valve screw	35	103635	Clamp Nut
15	0625-ZZ0A	Ball Bearing	36	103636	Spindle
16	103416	Rear End Plate	37	103637	Key
17	P-0025-060	Pin (2)	41	103441	Double Ended Spanner (2)

PLEASE READ FOLLOWINGS CAREFULLY BEFORE OPERATING:

- 1) Always wear Safety Goggles to guard against eye injuries caused by flying particles.
- 2) Light density, non-detergent lubricant oil (i.e.#60) recommended.
- 3) Use air working pressure of 0-90 PSIG, regular speed: 18,000 RPM.

Notice

90% of all Air Tool problems are caused by moisture in air lines

This problem can be avoided by using Air Tool Lubricant (See “Lubrication” & “Air Supply” section of this manual)

FAILURE TO OIL can void your warranty

Warning: Dust created by power sanding, sawing, grinding, drilling, and other activities contains particles and chemicals known to cause cancer, birth defects or reproductive harm. Some examples of these chemicals are:

- Lead from lead-based paints
- Crystalline silica from bricks, cement and other masonry products
- Arsenic and chromium from chemically treated lumber

To reduce your exposure to these chemicals, work in well ventilated areas with approved safety equipment specially designed to filter out microscopic particles.

One Year Limited Warranty

GLOBAL Industrial air tools carry a 1 year warranty to be free from defects in material and workmanship for one year from date of purchase. We will repair or replace at our discretion any defective part or unit which proves to be defective in material or workmanship during this 1 year period. The foregoing obligation is GLOBAL sole liability under this or any implied warranty, and under no circumstances shall it be liable for any incidental or consequential damages.

Repairs required by abuse, misuse, damage, or repair attempts (other than GLOBAL Industrial) are not covered by this warranty.

For warranty claims and returns, please contact GLOBAL Industrial at 1-800-645-2986 or speak to your local sales representative. Be certain to include your name, address, and purchase date, and description of the suspected defect.



11 Harbor Park Drive, Port Washington, NY 11050

Phone: 1-800-645-2986