



## Model # G3999 2" Miniature Rotary Action Sander

### Operating Instructions, Parts List, Warranty, & Warranty Repair Center

**IMPORTANT!** Read carefully before operating this tool. Failure to operate any power tool properly can result in personal injury and/or property damage!

Free Speed (RPM) .....	15,000	Disc Size .....	2"
Air pressure (PSI) .....	.90	Avg. Air Consump.(cfm).....	3
Hose Size (ID) .....	3/8"	Overall Length .....	3.7"
Air Inlet (NPT) .....	1/4"	Weight (Lbs) .....	1.5

### Safety

1. Always use impact type sockets that are designed for impact wrenches.
2. Always wear approved eye protection.
3. Have throttle in "off" position when connecting to air supply.
4. Disconnect tool before performing service, changing accessories, or when not in use.
5. Always be in a safe working distance from others when using tools.
6. Keep tools clean and oiled for best and safest performance.
7. Follow instructions for lubricating and changing accessories.
8. Do not wear loose fitting clothing and remove watches and rings.
9. Use proper hose and fitting. Never use quick change couplings attached at tool.
10. Keep proper footing and balance at all times.
11. Never carry too by the hose. Keep hoses from heat, oil, and sharp edges. Check hoses for weak or worn condition before each use, making certain that all connections are secure.

### Lubrication

Lubricate the tool daily with a good grade of air tool oil. The oil can be applied directly into the air inlet of the tool and then run the tool. A rust inhibitor oil is acceptable for air tools.

### Air Supply

Tools of this class operate on a wide range of air pressure. It is recommended that air pressure of these tools measure 90 PSI at the tool while running free. Higher pressure and unclean air will shorten the tool's life and may create a hazardous condition.

Water in the airline will cause damage to the tool. Ensure that the air tank is drained daily. Clean the air inlet filter screen on at least a weekly basis. The recommended hookup procedure can be viewed in the illustration below.

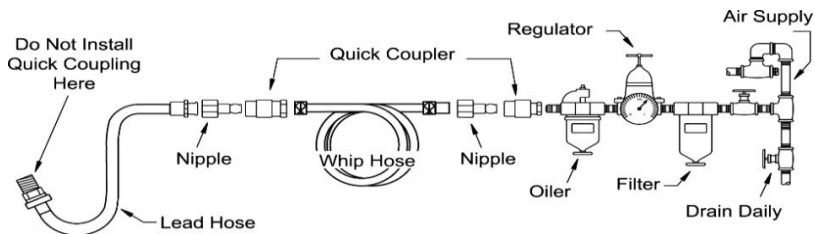

The air inlet, used for connecting air supply, has standard 1/4" NPT American Thread.

Line pressure should be increased to compensate for unusually long air hoses (over 25 feet). Minimum hose diameter should be 1/4" I.D. and fittings should have the same inside dimensions.

## Maintenance

Other factors outside the tool may cause loss of power or erratic action. Reduced Compressor output, excessive drain on the air line, moisture or restriction in air pipes or the use of hose connections of improper size or poor condition may reduce air supply. Grit or gum deposits in the tool may cut power and may be corrected by cleaning the air strainer and flushing out the tool with gum solvent oil or an equal mixture of SAF#10 oil and kerosene. If outside conditions are in order and tool is out-of-warranty, clean, reassemble, and re-lubricate, or take tool to any air tool service center. For tools in warranty period, send tool direct to Warranty Center.

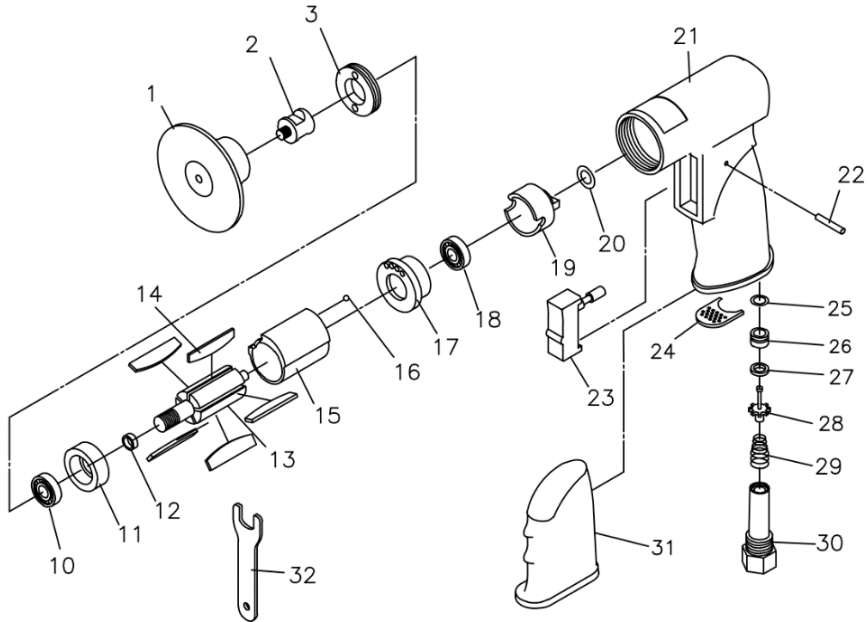

No.	Part No.	Description	No.	Part No.	Description
1	TSAG006R3V	2" Rolok Disc Holder	20	TS70610	O-Ring
2	TS93102	Spindle	21	TS93121W	Housing
3	TS93103	Clamp Nut	22	TS93122A	Pin
10	TS70624	Ball Bearing	23	TS93123A	Trigger
11	TS93111	Front End Plate	24	TS93124	Exhaust Deflector
12	TS70623	Spacer	25	TS12025	O-Ring
13	TS93113	Rotor	26	TS93126	Bushing
14	TS70520	Rotor Blade (5)	27	TS93127	Throttle Seat
15	TS93115	Cylinder	28	TS93128	Throttle Valve
16	TS70521	Steel Ball	29	TS93129	Throttle Spring
17	TS93117	Rear End Plate	30	TS93130	Air Inlet
18	TS70517	Ball Bearing	31	TS93131W	Comfort Grip
19	TS93119	Regulator	32	TS93132	Wrench 12mm

**PLEASE READ FOLLOWINGS CAREFULLY BEFORE OPERATING:**

- 1) Always wear Safety Goggles to guard against eye injuries caused by flying particles.
- 2) Light density, non-detergent lubricant oil (i.e.#60) recommended.
- 3) Use air working pressure of 0-90 PSIG, regular speed: 15,000 RPM.

## Notice

**90% of all Air Tool problems are caused by moisture in air lines**

**This problem can be avoided by using Air Tool Lubricant (See “Lubrication” & “Air Supply” section of this manual)**

**FAILURE TO OIL can void your warranty**

**Warning:** Dust created by power sanding, sawing, grinding, drilling, and other activities contains particles and chemicals known to cause cancer, birth defects or reproductive harm. Some examples of these chemicals are:

- Lead from lead-based paints
- Crystalline silica from bricks, cement and other masonry products
- Arsenic and chromium from chemically treated lumber

To reduce your exposure to these chemicals, work in well ventilated areas with approved safety equipment specially designed to filter out microscopic particles.

## One Year Limited Warranty

GLOBAL Industrial air tools carry a limited 1 year warranty to be free from defects in material and workmanship for one year from date of purchase. We will repair or replace at our discretion any defective part or unit which proves to be defective in material or workmanship during this 1 year period. The foregoing obligation is GLOBAL sole liability under this or any implied warranty, and under no circumstances shall it be liable for any incidental or consequential damages.

Repairs required by abuse, misuse, damage, or repair attempts (other than GLOBAL Industrial) are not covered by this warranty.

**For warranty claims and returns, please contact GLOBAL Industrial at 1-800-645-2986 or speak to your local sales representative. Be certain to include your name, address, and purchase date, and description of the suspected defect.**



11 Harbor Park Drive, Port Washington, NY 11050

Phone: 1-800-645-2986