

User's manual

Manual del usuario

Manuel de l'utilisateur

Customer Service
US: 1-800-645-2986Servicio de atención al Cliente
US: 1-800-645-2986Service à la clientèle
Canada: 888-645-2986

Single Docking Station

Model: 812548

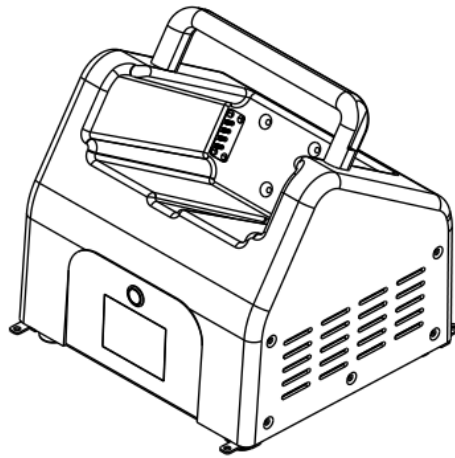

Read this manual thoroughly prior to installation, operation or maintenance. Keep these instructions in a safe location for future reference. For questions, visit globalindustrial.com or contact Customer Service at 1-800-645-1-800-645-2982.

WARNING

- Failure to follow installation instructions will void warranty.
- When plugging in or pulling out the battery, please be cautious about the operation to avoid pins damage;
- The product should be kept away from fire, high-temperature environments, and humid and rainy environments during use and storage, otherwise it may lead to dangerous situations.
- Non-professionals should not disassemble it by themselves.
- Do not discard the product at the end of its service life. Recycle the product according to local laws and regulations.
- This product should be protected from rain, water immersion, moisture, and violent vibration during transportation.
- It cannot be used at an altitude exceeding 2000m.
- Do not drop, squeeze, or collide with the product, so as not to subject the product to external pressure, which may cause a short circuit of the internal circuit of the product and damage to the battery.
- After use, please turn off the machine in time.
- Please charge by the supplied power cord.
- When the product accidentally drops into the water while using, please unplug the input socket and place it in a safe and open area. The product shall not be turned on.
- While using or delivering the product, its screen should be carefully protected from strike.
- When the product is on, it is forbidden to touch pins in the battery compartment with hands or metal devices.

Single Docking Station 812548

Technical parameters

Item	Parameter
Output Power	500W
Peak Power	1000W
Overload Protection	580W 30S
Output Voltage	110V 60Hz
Adaptive Battery	LiFePO4 8S 20/25AH
Other Function	When the battery level is $\leq 16\%$, the buzzer rings three times at 1-minute interval and the screen will flash along with the alarm; When the battery level is $\leq 6\%$, the buzzer rings constantly. When the battery level is $< 5\%$, the output will cut off. When the output load is $\geq 500WZ$, the screen will pop up the overload icon. 
Product Size	10.23 x 10.55 x 10.47 inch (L*W*H)
Product N.W.	9.19 lbs
Product G.W.	12.25 lbs
Working Environment	14-104°F Relative Humidity $\leq 80\%$ Altitude $\leq 2000M$
Transport and Storage Environment	Temperature: 5-131°F Relative Humidity $\leq 93\%$ (no condensation) Atmosphere Pressure: 70kPa ~ 106kPa

Package Contents:

- Single Docking Station * 1
- Product Instruction Manual * 1

Single Docking Station 812548

Application and Function Instruction:

The single docking station is with internal 500W pure sine wave inverter. Insert the battery into the plastic station and turn the power on. The inverter output is AC 110V 60Hz, being able to power products $\leq 500W$. The product is equipped with functions like overload protection, short circuit protection, low battery level prompt and low battery over-discharge protection. It has a 1.7-inch LCD screen, displaying the current battery level and overload icon.

Product Main Structure Composition

The docking station is mainly composed of a sheet-metal base, battery plastic base, inverter, control panel and LCD screen.

Front of Docking Station

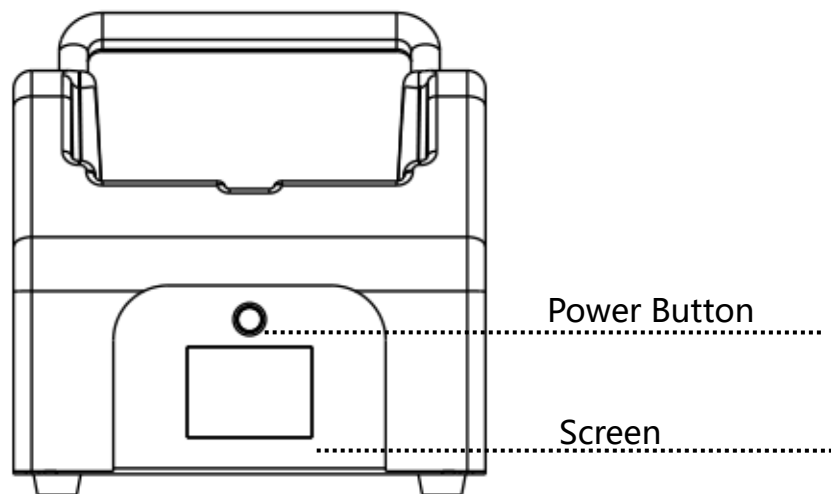

Rear of Docking Station

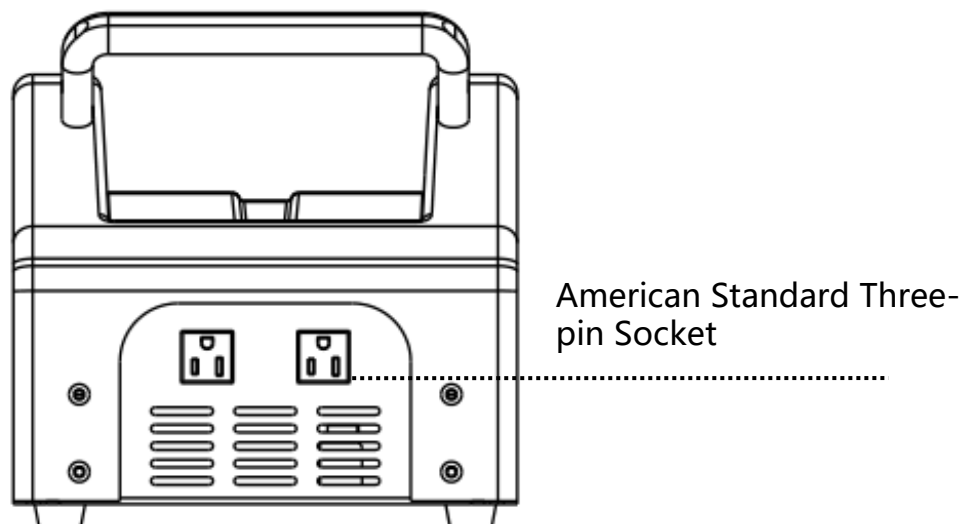

Single Docking Station 812548

Operation and Usage

1. Check whether there is any visible damage to the appearance of the product and whether the output socket or the battery pins are loose or damaged (If abnormal conditions occur, stop using).
2. Confirm that whether the power of loaded device is within the specified range of the dual docking station. Then plug the device into the AC socket on the back of the product.
3. Plug the battery into the plastic battery compartment in the product.
4. Turn on the power switch. Then the device starts and the internal inverter works. The load should work normally. When the screen works normally, it shows that the corresponding battery is working.
5. When the product alarms a low-battery prompt, it should be turned off immediately and the battery needs to be replaced by a new one.

Product Maintenance

1. Socket contacts in the battery compartment are fragile so they should be inspected regularly. The deformed or cracked one should be replaced. Otherwise, it may cause charging failure.
2. Regularly remove dust and dirt from the heat dissipation window.
3. Regularly check whether the external screws and lifting rings of the chassis are fully tightened;

Troubleshooting

Issue: No Response When Power on

Suggested Action:

- Confirm whether the battery is completely inserted into the battery compartment and the sockets in the bottom of the battery should be completely connected to the battery station pins.
- Check whether the battery station pins are deformed or falling off.
- Make sure whether the battery is fully charged.