



BY  **IRONWOOD**

## LIBRARY SHELVING UNIT

**LS42DB LS48DB  
LS60DB LS72DB  
LS84DB**

### DOUBLE BASE UNIT

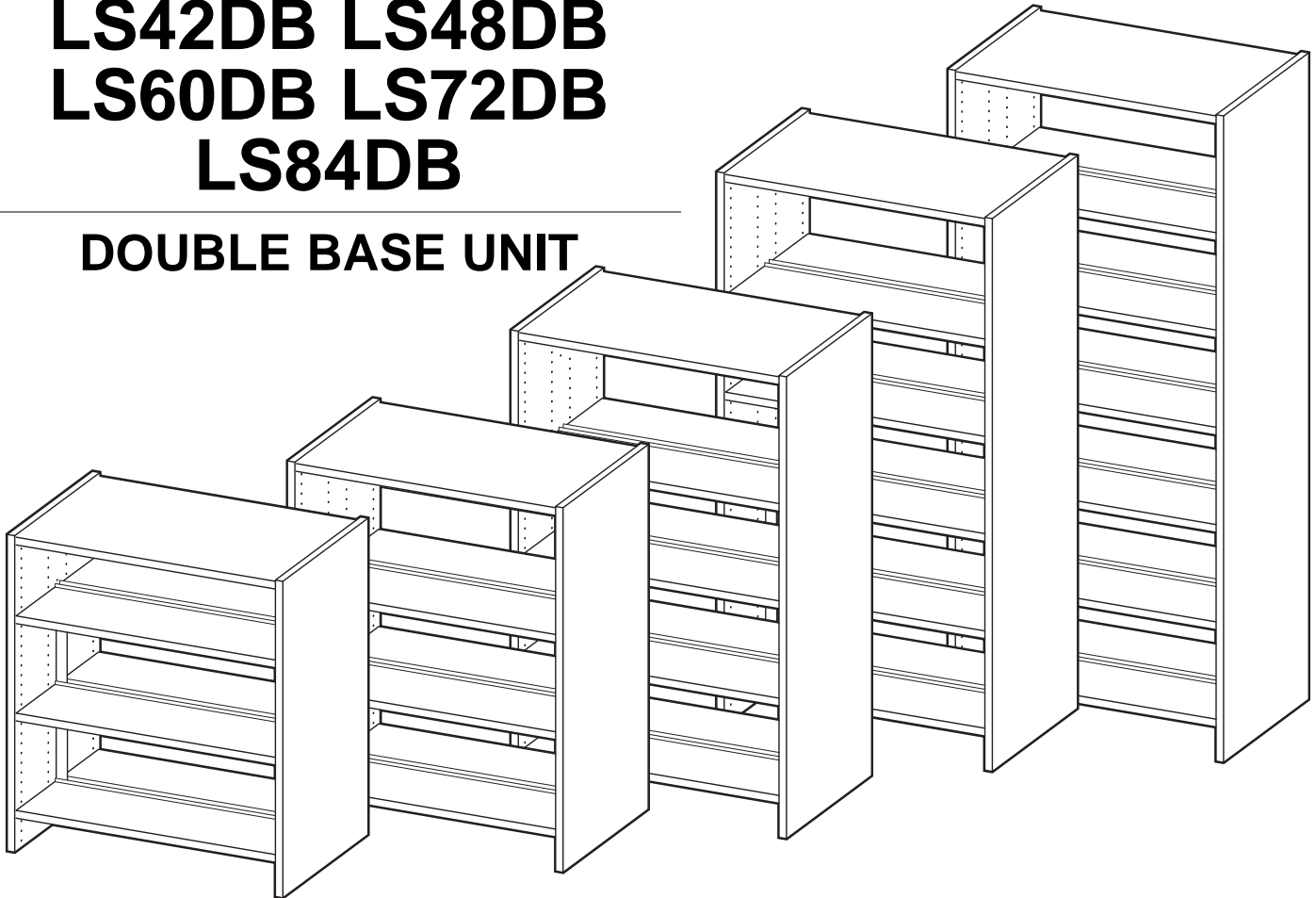

### IMPORTANT!

**Assembly may require the assistance of another person.**

**Before you begin assembly:**

**READ THE DIRECTIONS** all the way through one time. This will speed up the process and help you understand the sequence of steps.

**COUNT THE PARTS AND HARDWARE** before assembly. This ensures you have received all necessary parts before you begin.

**TOOLS:** You may need a Phillips head screwdriver, a medium slotted screwdriver or a plastic mallet. To protect your new furniture from damage during assembly, it is recommended to work on a carpeted surface.

In the event any parts are missing from this package, send your name, address, telephone number, and a description of the missing part(s) to: **PARTS, Box 1420, Missoula, MT 59806** or call: **1-800-769-5693** or FAX **1-800-445-5281**.

**CAUTION:** On assemblies requiring glue, make sure the unit is assembled correctly before gluing. Once this unit is assembled with glue, the manufacturer will not be responsible for damaged parts. Keep a damp cloth or sponge handy to wipe off excess glue.

To care for this furniture, simply wipe with a cloth dampened with glass cleaner containing ammonia-D.

## PARTS DIAGRAM

The diagram show one size for ease of viewing. Any differences will be indicated in each part's description.

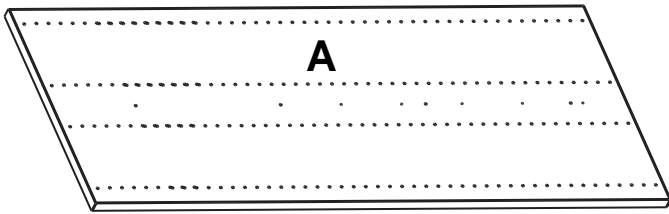

Side	LS42DB	01300141	2 ea.
	LS48DB	01300241	2 ea.
	LS60DB	01300341	2 ea.
	LS72DB	01300441	2 ea.
	LS84DB	01300541	2 ea.

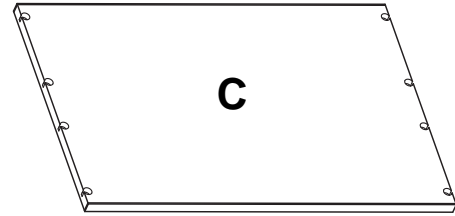

Top	01300101	1 ea.
-----	----------	-------

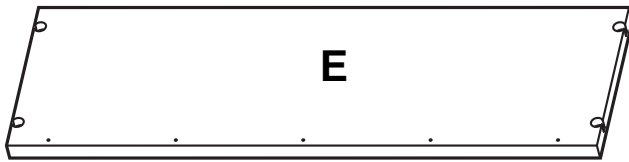

Fixed/ Adjustable Shelf	LS42DB	01200124	6 ea.
	LS48DB		6 ea.
	LS60DB		8 ea.
	LS72DB		10 ea.
	LS84DB		12 ea.

## HARDWARE



H1	Tab-V Plastic Housing	909930	LS42DB - 32 ea.
			LS48DB - 32 ea.
			LS60DB - 40 ea.
			LS72DB - 48 ea.
			LS84DB - 56 ea.

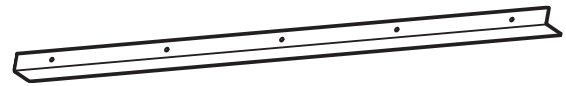

H2	Book Stop	412226	LS42DB - 6 ea.
			LS48DB - 6 ea.
			LS60DB - 8 ea.
			LS72DB - 10 ea.
			LS84DB - 12 ea.



H3	# 8 x 5/8" Panhead Screw	988056	LS42DB - 40 ea.
			LS48DB - 40 ea.
			LS60DB - 50 ea.
			LS72DB - 60 ea.
			LS84DB - 70 ea.

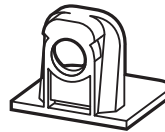

H4	Tab-V Metal Flange	909931	16 ea.
----	-----------------------	--------	--------



H5	Varianta Screw	988060	16 ea.
----	----------------	--------	--------

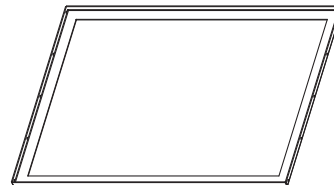

H6	Metal Frame	412026	1 ea.
----	-------------	--------	-------

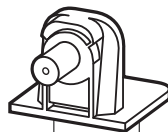

H7	Tab-V Metal Shelf Clip	909932	LS42DB - 16 ea.
			LS48DB - 16 ea.
			LS60DB - 24 ea.
			LS72DB - 32 ea.
			LS84DB - 40 ea.

If you have purchased an Adder unit  
to be assembled in conjunction with this Base unit,

it is important to read all the way through the Adder instructions  
(enclosed in the Adder carton) before beginning. It will be necessary  
to substitute a Divider (J) for a Right Side (B) during assembly.

If you have purchased the Back option or the Toe Space option  
to be assembled in conjunction with this Base unit,

it is important to read through the Back option  
and/or Toe Space option directions before beginning.

**NOTE:**

**The diagrams show one size for ease of viewing.  
Any differences will be indicated in each step's text.**

## USING THE TAB-V SYSTEM:

Using a plastic mallet, tap in the plastic housings with the flat edge facing outwards until flush with the surface.

**IMPORTANT!** The flat edge of the plastic housing must be aligned with the shelf edge. Plastic Housings cannot be repositioned once installed.

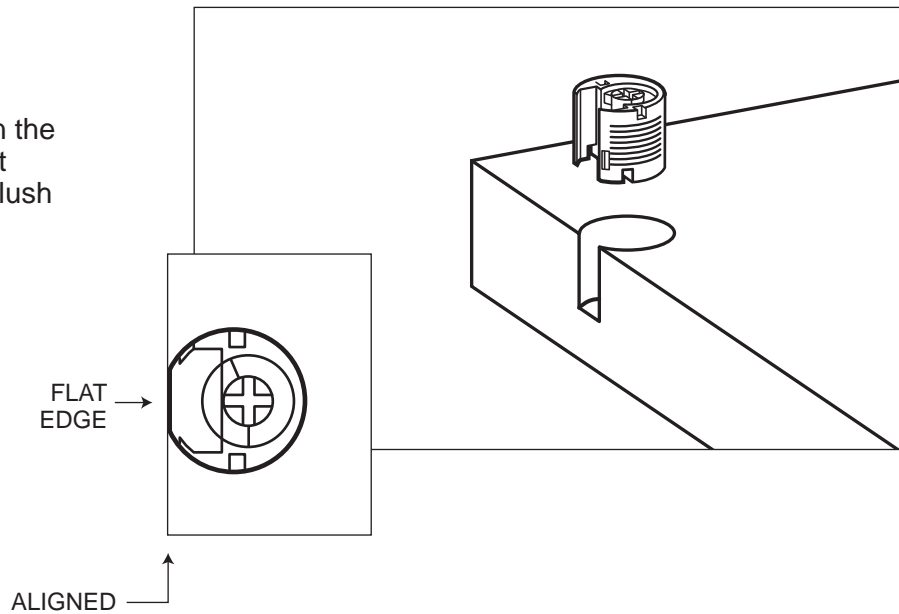

For a Fixed Shelf or Top, install the metal flange using a System (Varianta) Screw as shown. **DO NOT** over tighten!

For an Adjustable Shelf, use the Metal Shelf Clip.

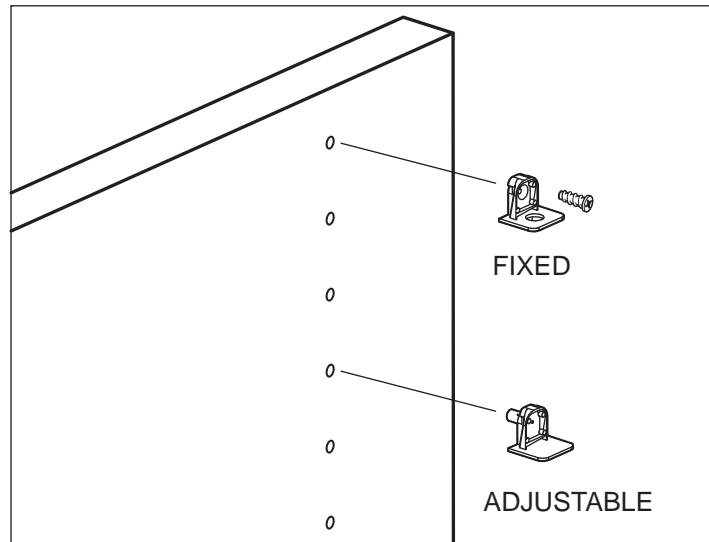

Slide the shelf into place over the Metal Flanges and push down until fully seated.

Turn the rotating portion (Cam) 1/2 turn to lock in place.

To remove, simply turn the Cam counter clockwise 1/2 turn and lift the shelf off of the Metal Flanges.

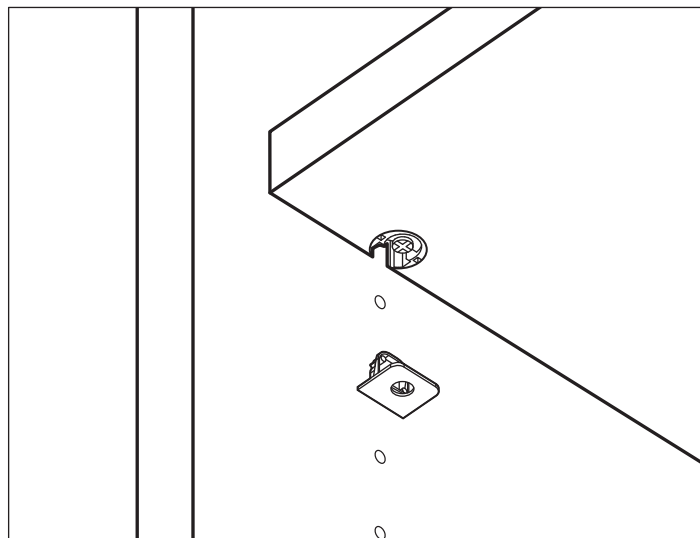

### Using the Minifix System:

Insert the Minifix Cams into the appropriate holes with the arrow facing outwards as shown.

When screwing post into hole, **Do Not** over tighten. Screw post down until bottom face of post flange just touches board surface.

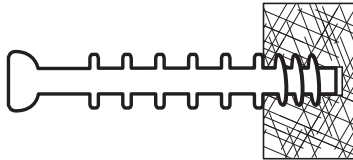

Using the #2 Phillips screwdriver, rotate the Cam Devices a half turn clockwise until snug.

To disassemble, turn the Cam Devices counter-clockwise and remove panels.

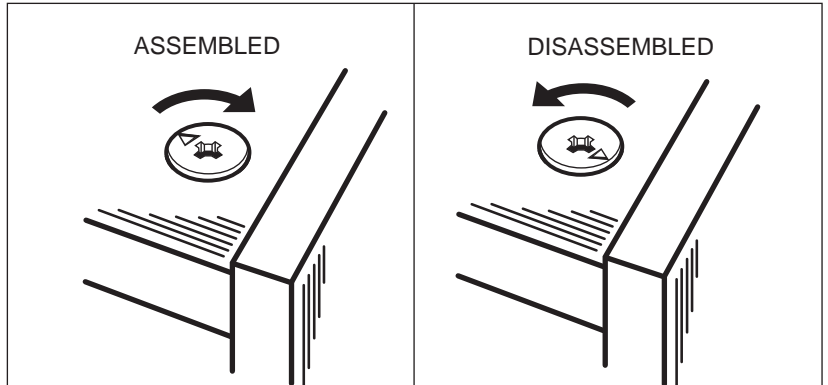
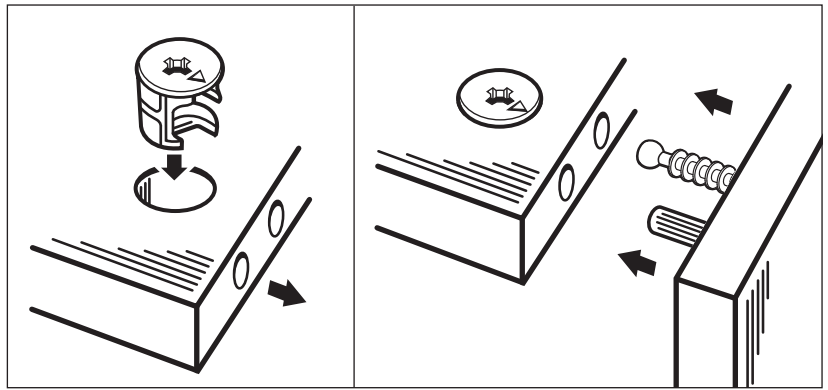

## #1

Install four Plastic Housings (H1) into each shelf. Attach a Book Stop (H2) to each Fixed/Adjustable Shelf (E) using five Panhead Screws (H3) in the pre-drilled holes.

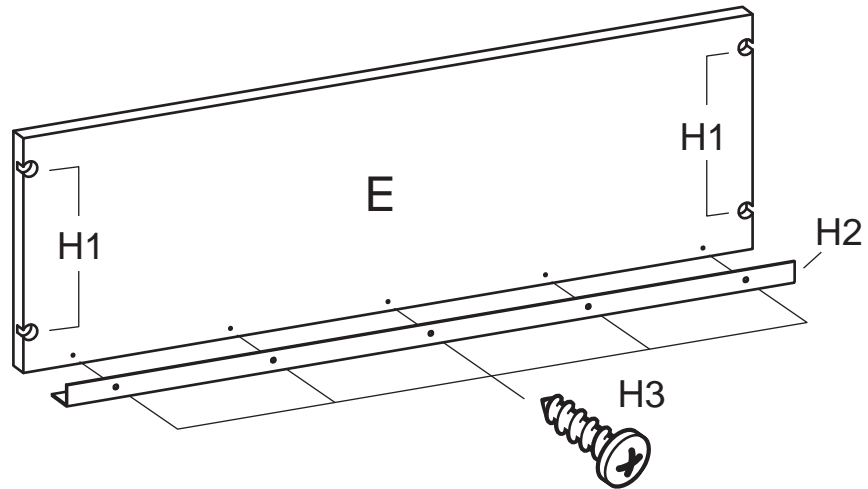

## #2

Install eight Plastic Housings (H1) into the Top Panel (C) as shown.

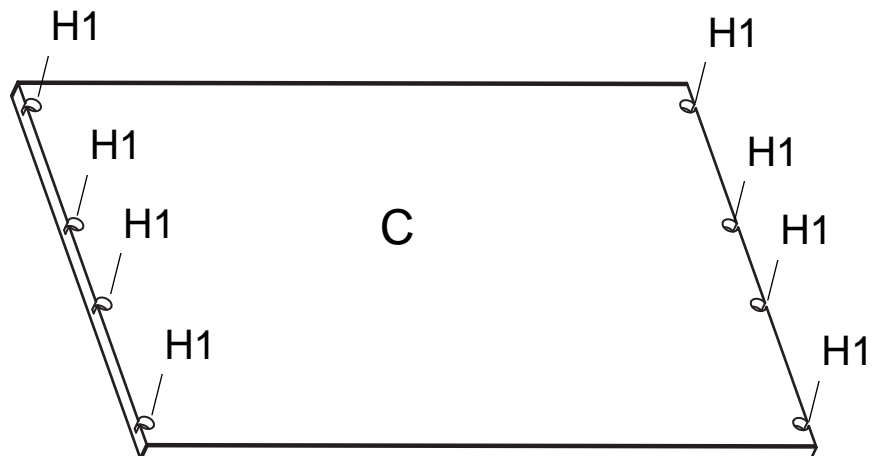

**#3**

Place both Side (A)'s on a clean, carpeted surface as shown. Install Metal Flanges (H4) using Varianta Screws (H5) in each Side Panel into the selected pre-drilled holes as indicated.

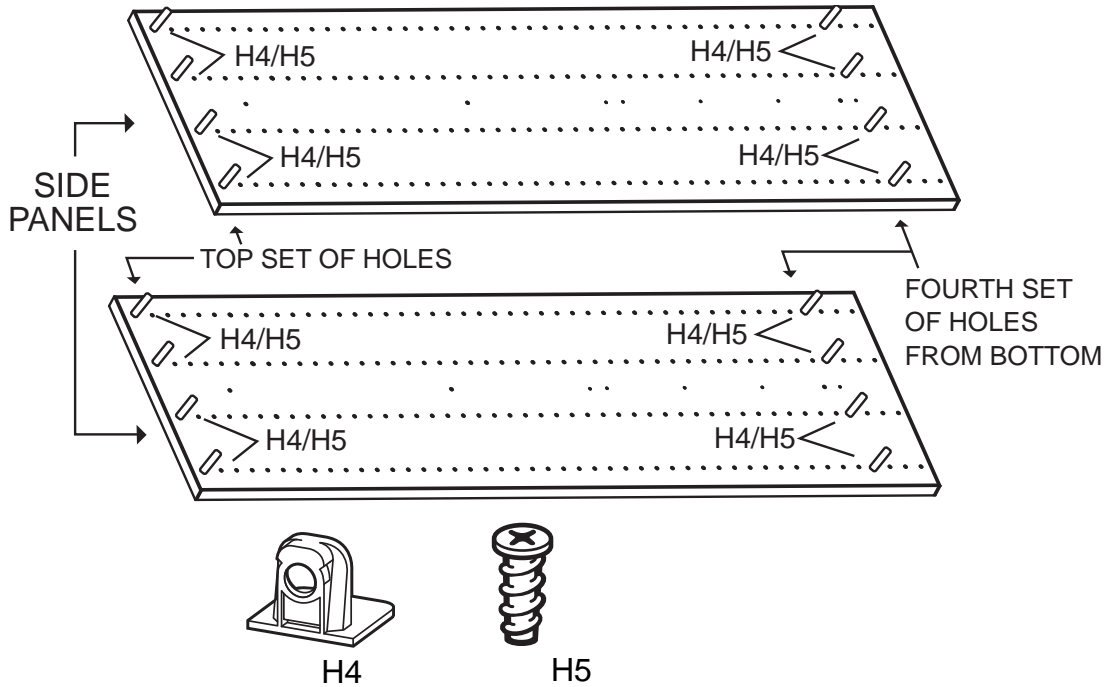

**#4**

For a Metal Frame, attach the Frame (H6) as shown using five #8 x 5/8" Panhead Screws.

For a 3/4" Back, follow the directions for a Back Panel. Attach the Back Panel (D) to the Side (A) as shown. Tighten the Rafix Cams (H8) 1/2 turn.

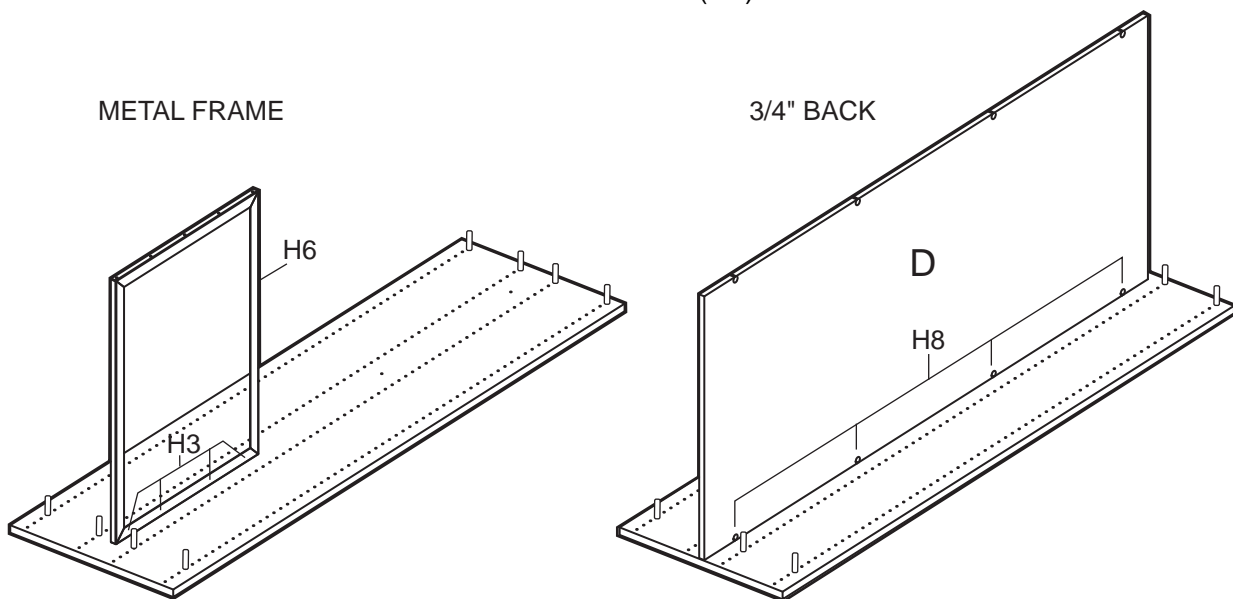

**NOTE:** If you are installing an Adder, follow the instructions for an Adder unit at this time.

#5

With the assistance of another person, stand the assembly upright and attach the other Side Panel.

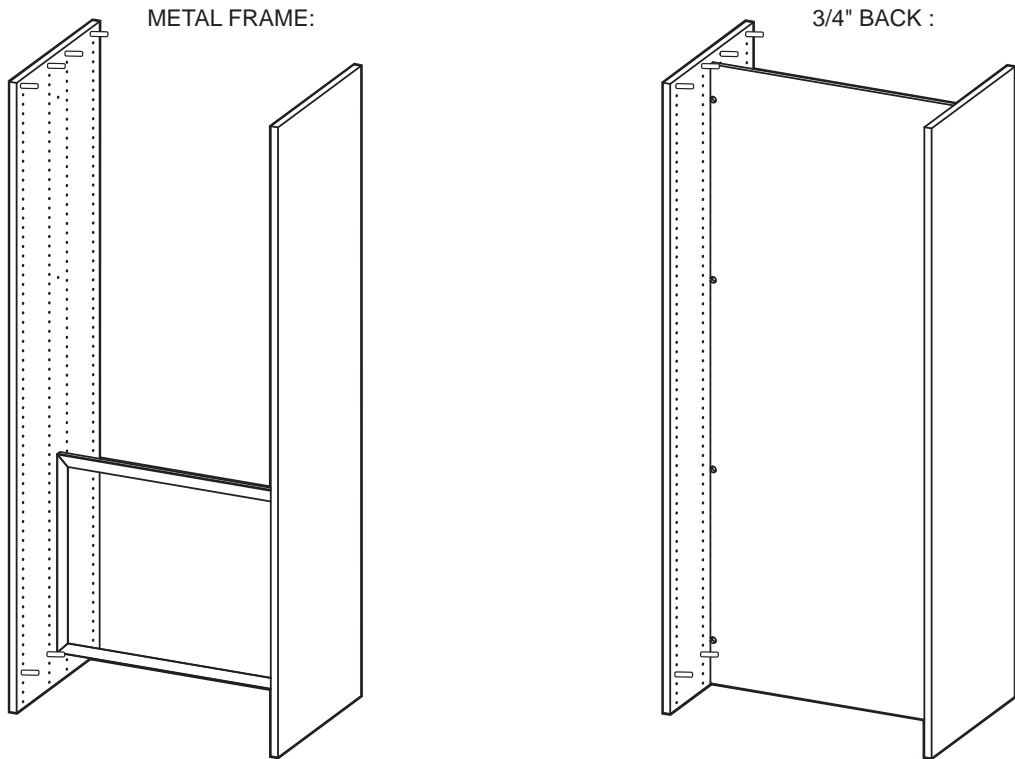

**NOTE: If you are installing the Toe Space option, it is recommended to install the Toe Space at this time. Follow the directions included with the Toe Space option.**

#6

Attach the Top Panel (C) using the Tab-V System. Turn the eight Tab-V Cams (H1) 1/2 turn clockwise to secure.

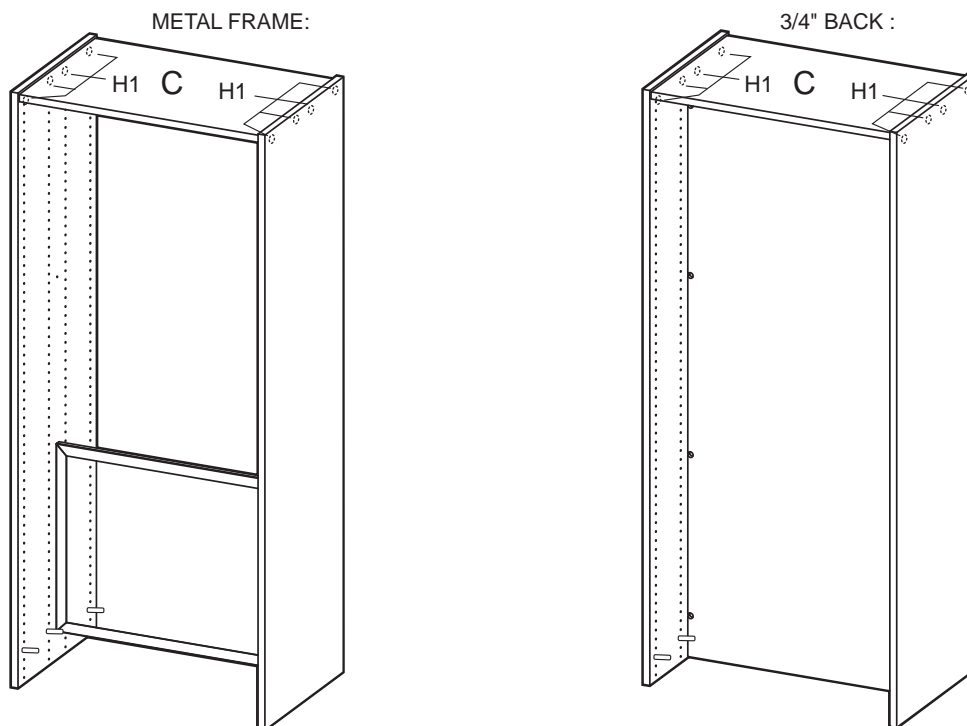

#7

Attach two Fixed Shelves (E) in the same manner.

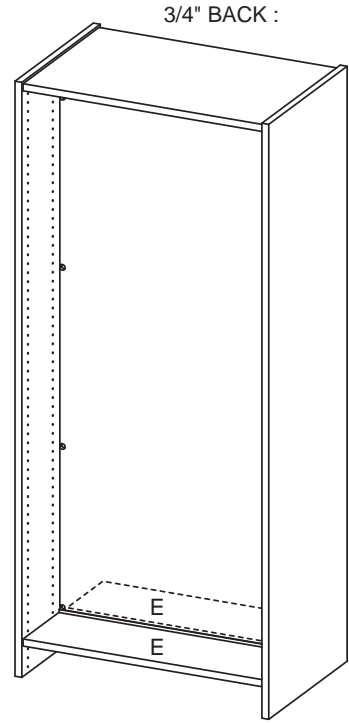
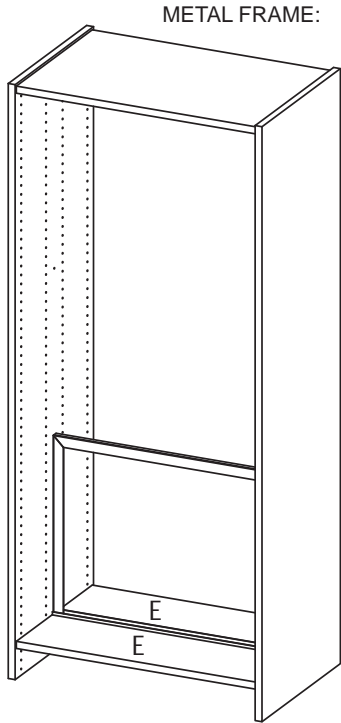

#8

Placement of the Adjustable Shelves is optional. The diagram below shows a recommended placement for the spacing of the shelves.

**NOTE:** The diagram shows the LS84DB. The shorter bookcases will use the appropriate sets of placements.

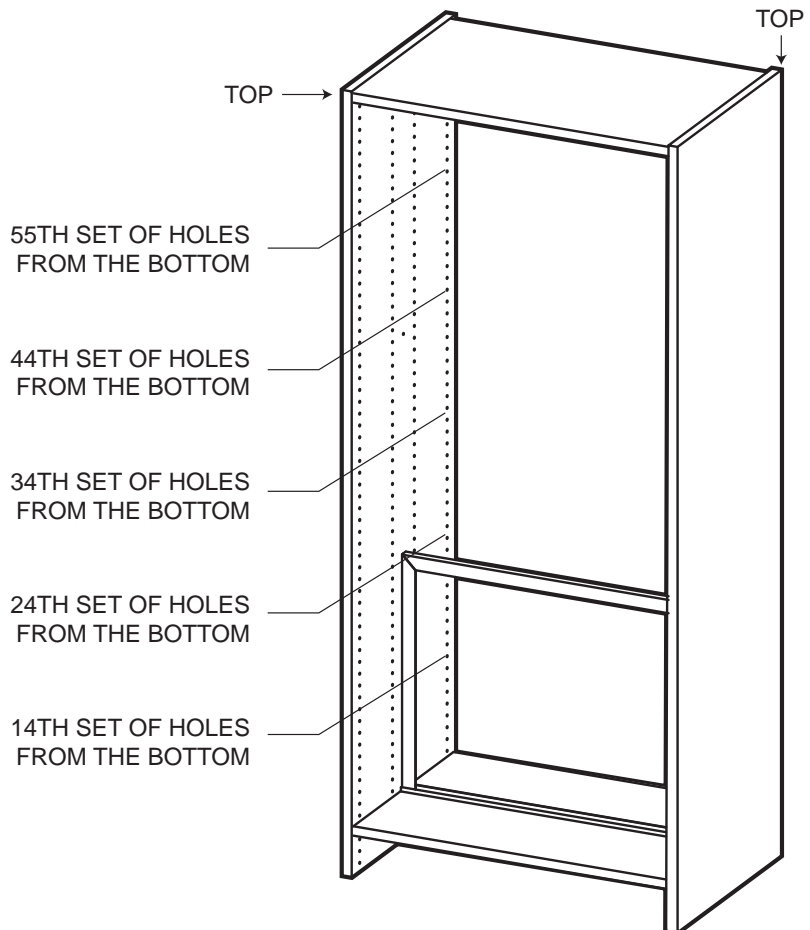



#9

Insert Metal Shelf Pins (H7) into both Sides at the preferred heights for the Adjustable Shelves.

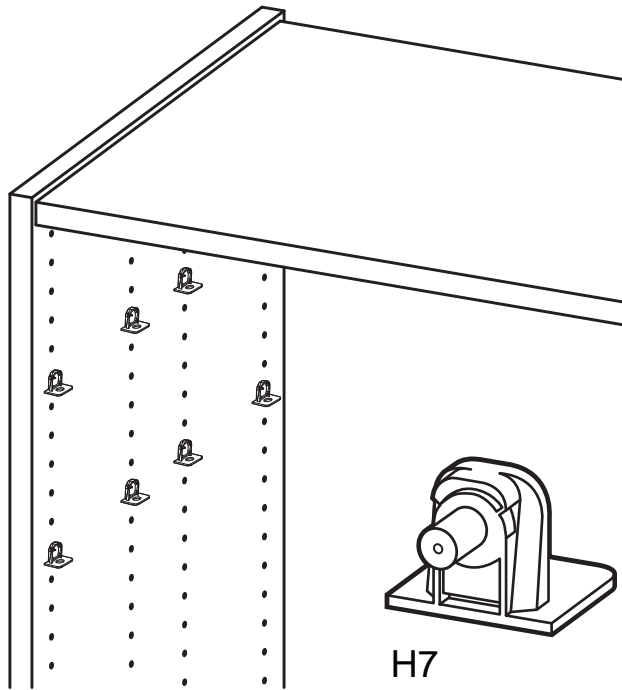

#10

Place the Adjustable Shelves (E) into each side of the unit, and lock the Tab-V cams to secure.

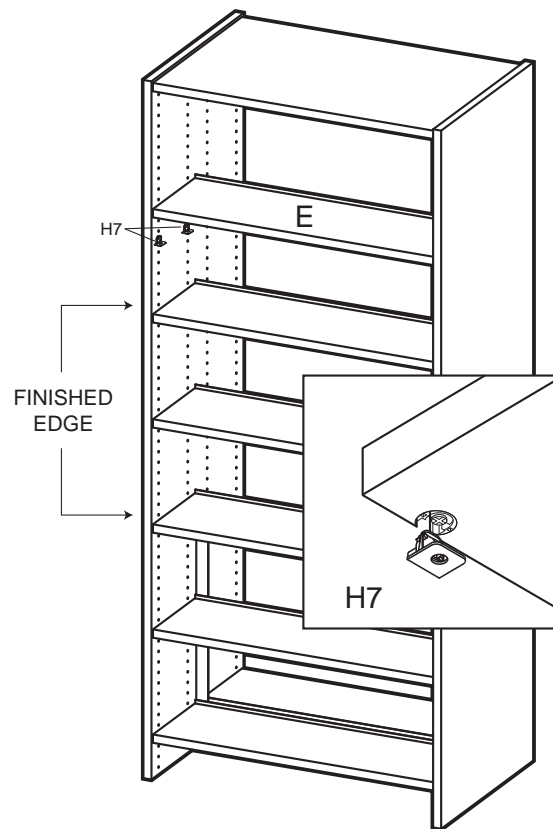

**#11**

**Your Glacier Library Shelving unit is now assembled and ready for use.**

