

CDTD-39

Two Drawer Unit

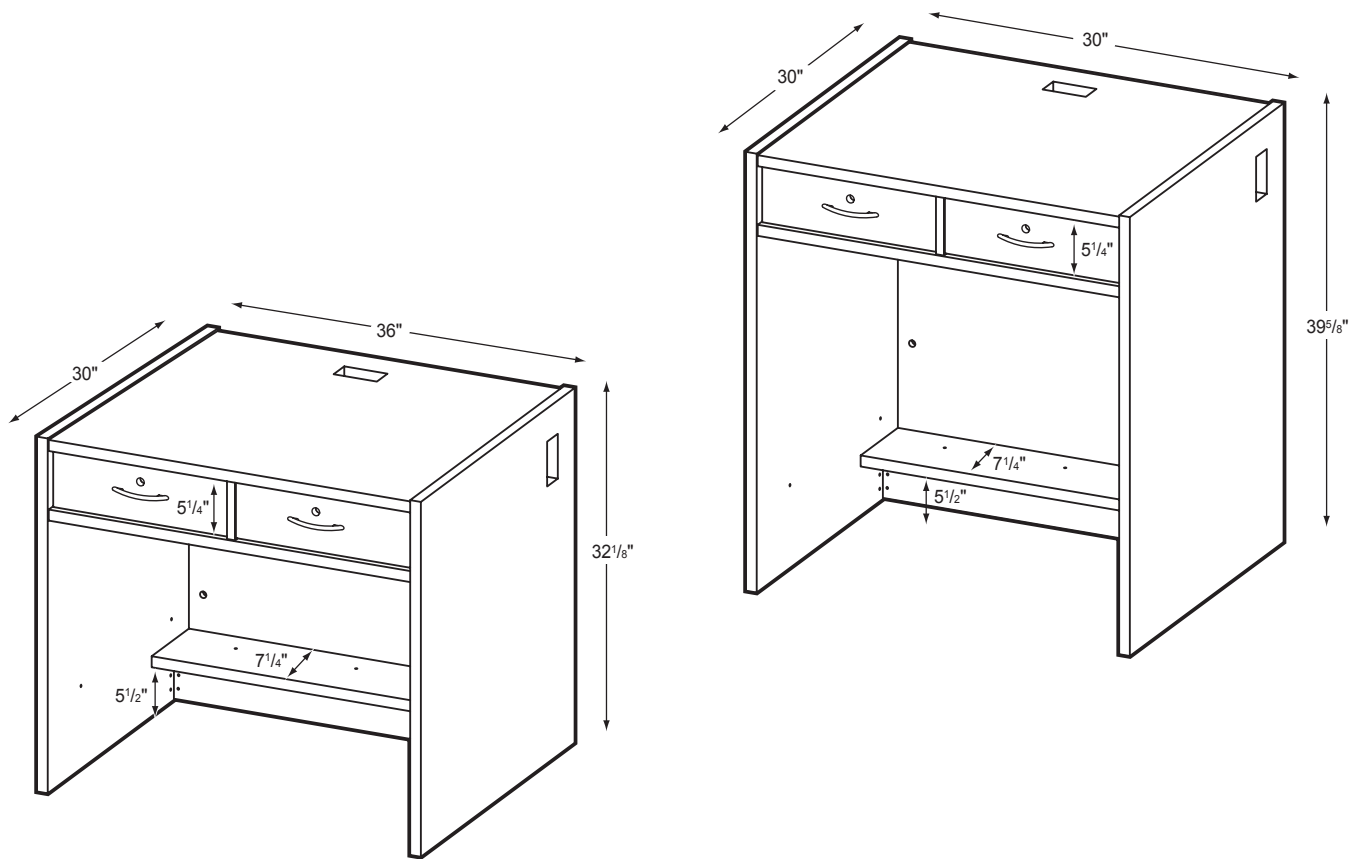

Product Specs

- 1" thermal fused laminate sides and top
- 3/4" thermal fused laminate modesty, shelf and kick
- Cam and post construction
- Matched edge banding
- Fixed storage shelf
- Locking drawers on 2/3 extension steel slide
- Three - 2"x 4" grommets with covers
- Wire management tray
- Adjustable leveling glides