

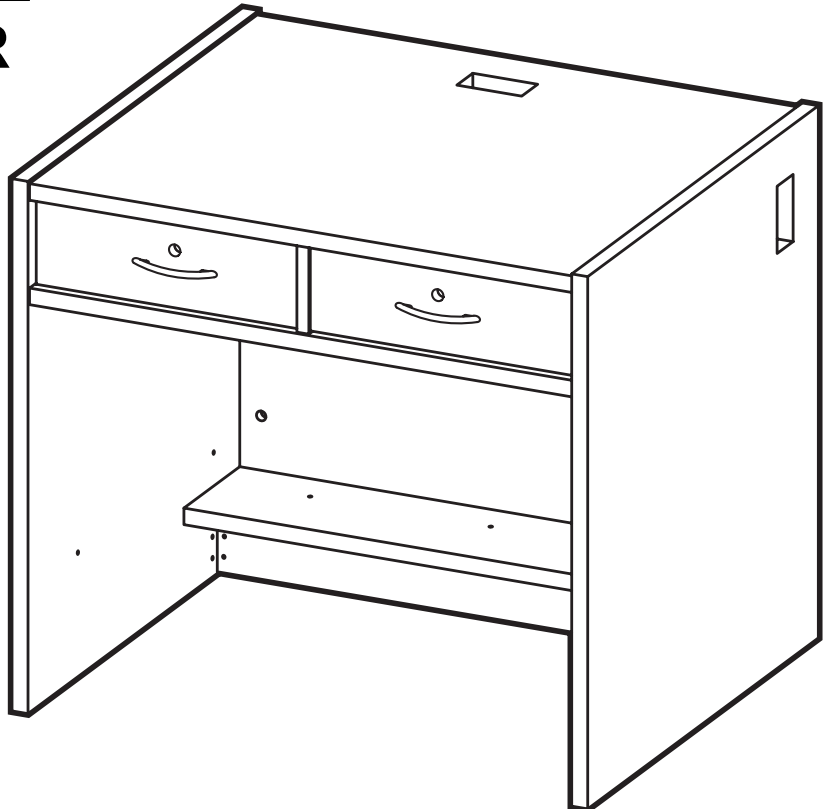

BY  **IRONWOOD**

CDTD CDTD39

TWO DRAWER UNIT



IMPORTANT!

Assembly may require the assistance of another person.

Before you begin assembly:

READ THE DIRECTIONS all the way through one time. This will speed up the process and help you understand the sequence of steps.

COUNT THE PARTS AND HARDWARE before assembly. This ensures you have received all necessary parts before you begin.

TOOLS: You may need a Phillips head screwdriver, a medium slotted screwdriver or a plastic mallet. To protect your new furniture from damage during assembly, it is recommended to work on a carpeted surface.

In the event any parts are missing from this package, send your name, address, telephone number, and a description of the missing part(s) to: **PARTS, Box 1420, Missoula, MT 59806** or call: **1-800-769-5693** or **FAX 1-800-445-5281**.

CAUTION: On assemblies requiring glue, make sure the unit is assembled correctly before gluing. Once this unit is assembled with glue, the manufacturer will not be responsible for damaged parts. Keep a damp cloth or sponge handy to wipe off excess glue.

To care for this furniture, simply wipe with a cloth dampened with glass cleaner containing ammonia-D.

PARTS DIAGRAM

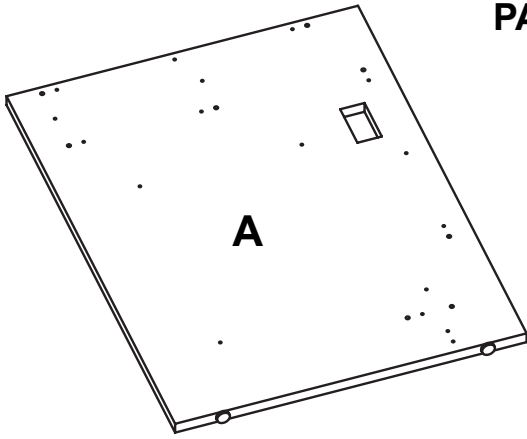

Left Side - CDTD	01010541	1 ea.
Left Side - CDTD39	0101641	1 ea.

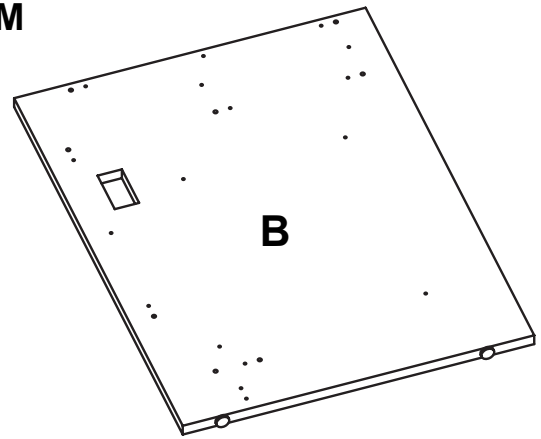

Right Side - CDTD	01010541	1 ea.
Right Side - CDTD39	01010641	1 ea.

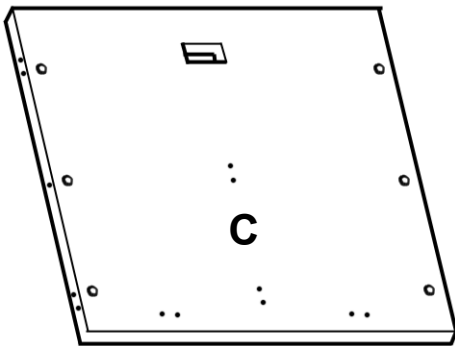

Top	01010501	1 ea.
-----	----------	-------

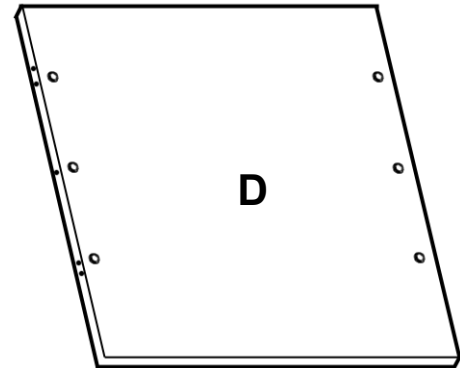

Back - CDTD	01010152	1 ea.
Back - CDTD39	01010252	1 ea.

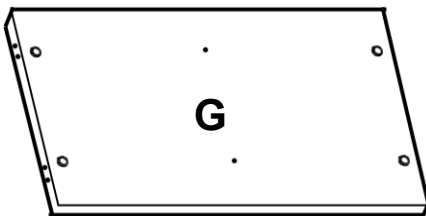

Top Shelf	01010502	1 ea.
-----------	----------	-------



Bottom	01010511	1 ea.
--------	----------	-------

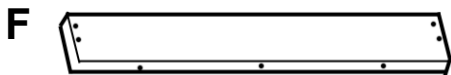

Toeboard	01010172	1 ea.
----------	----------	-------

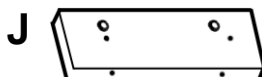

Divider	01010544	1 ea.
---------	----------	-------

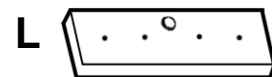

Drawer Front	01013063	2 ea.
--------------	----------	-------

D2

Drawer End	1069470	4 ea.
------------	---------	-------

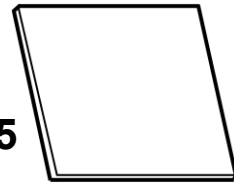
D5

Drawer Bottom	1191665	2 ea.
---------------	---------	-------

D1

Drawer Side	1069870	4 ea.
-------------	---------	-------

HARDWARE

H1	Leveler Insert	274650	4 ea.
----	----------------	--------	-------



H2	Leveler	300870	4 ea.
----	---------	--------	-------



H3	Minifix Bolt	909834	24 ea.
----	--------------	--------	--------



H4	Dowel	195000	18 ea.
----	-------	--------	--------



H5	Varianta Screw	988060	8 ea.
----	----------------	--------	-------



H6	Minifix Cam	909810	24 ea.
----	-------------	--------	--------

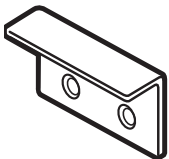

H7	Lock Stop	401230	2 ea.
----	-----------	--------	-------



H8	#6 x 5/8" Panhead Screw	901216	4 ea.
----	----------------------------	--------	-------

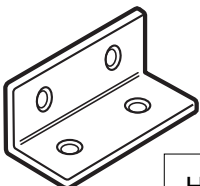

H9	Angle Bracket	401172	2 ea.
----	---------------	--------	-------



H10	#14 x 1/2" Panhead Screw	901233	8 ea.
-----	-----------------------------	--------	-------



H12	Washerhead Screw	920200	4 ea.
-----	---------------------	--------	-------



H11	Confirmat Screw	950100	21 ea.
-----	--------------------	--------	--------

LOCKSET 170-HP

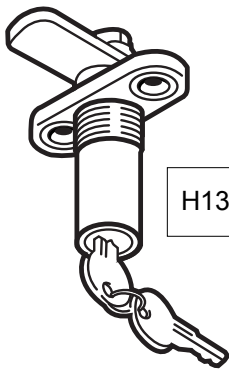

H13	Cam Lock	452310 452360	2 ea.
-----	----------	------------------	-------



H14	#6 x 5/8" Flathead Screw	901120	4 ea.
-----	-----------------------------	--------	-------



H15	Bezel	452350	2 ea.
-----	-------	--------	-------



H16	Drawer Handle	400870	2 ea.
-----	---------------	--------	-------

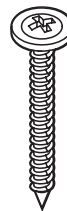

H17	1 1/2" Washerhead Screw	920202	4 ea.
-----	----------------------------	--------	-------



H18	#6 x 3/8" Panhead Screw	01115	12 ea.
-----	----------------------------	-------	--------



H19	Glue	295020	1 ea.
-----	------	--------	-------

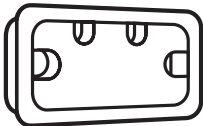

H20	Grommet	286580	3 ea.
-----	---------	--------	-------



H21	Connector Sleeve	950200	4 ea.
-----	---------------------	--------	-------



H22	Connector Screw	901350	4 ea.
-----	--------------------	--------	-------



H23	Hex Wrench	999995	1 ea.
-----	------------	--------	-------



S1	Full Extension Slide	490420	2 pr.
----	-------------------------	--------	-------

Using the Minifix System:

Insert the Minifix Cams into the appropriate holes with the arrow facing outwards as shown.

When screwing post into hole, **Do Not** over tighten. Screw post down until bottom face of post flange just touches board surface.

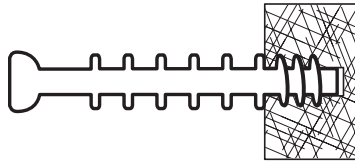

Using the #2 Phillips screwdriver, rotate the Cam Devices a half turn clockwise until snug.

To disassemble, turn the Cam Devices counter-clockwise and remove panels.

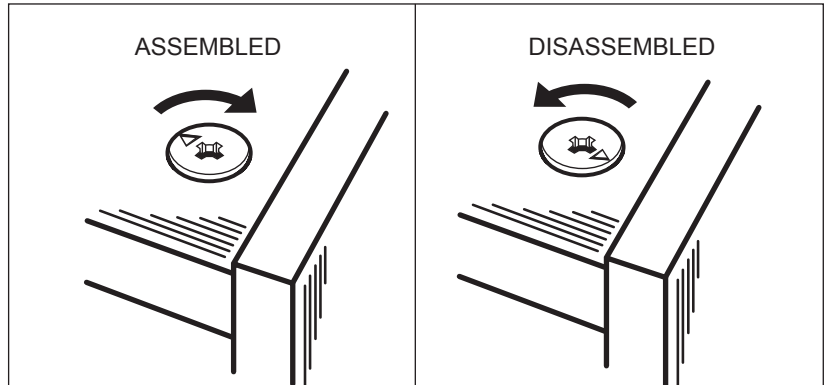
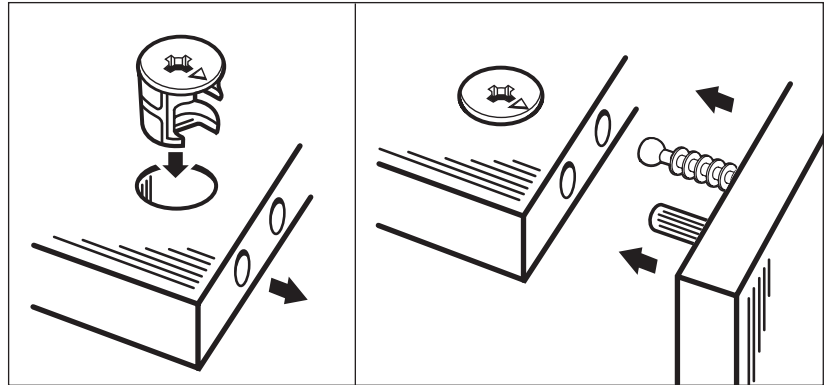

#1

Place the Left Side (A) and Right Side (B) on a clean carpeted surface with the pre-drilled holes facing up. Insert the Leveler Inserts (H1) into the holes in the bottom edges of each Side. Using a plastic mallet, tap until flush with the surface. Screw the Levelers (H2) into the Leveler Inserts.

Adjust Levelers when the assembled unit is in place.

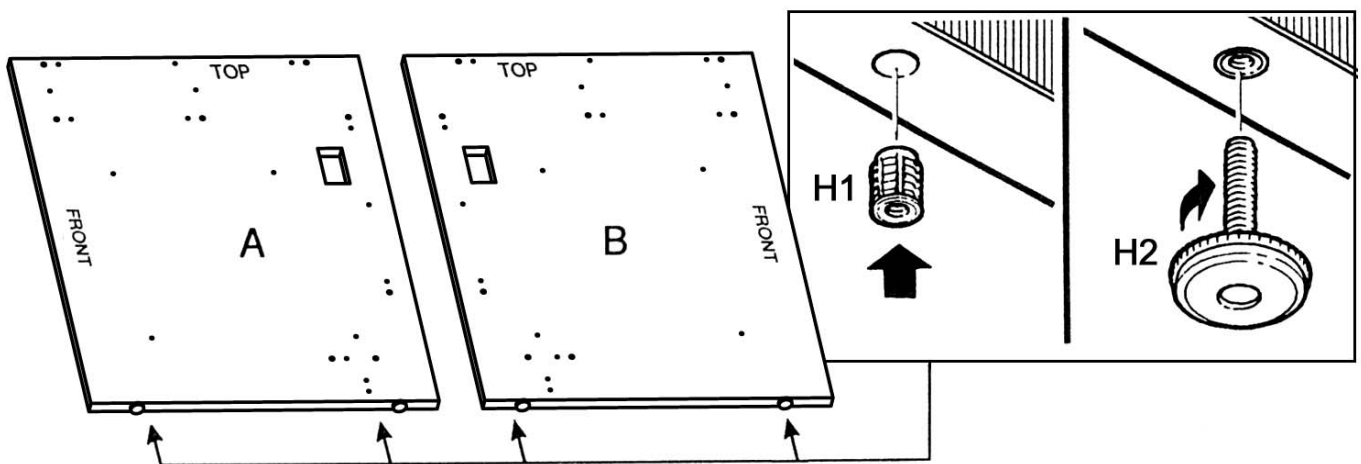

#2

Screw nine Minifix bolts (H3) and insert eight Dowels (H4) into the Left Side Panels (A & B) where indicated.

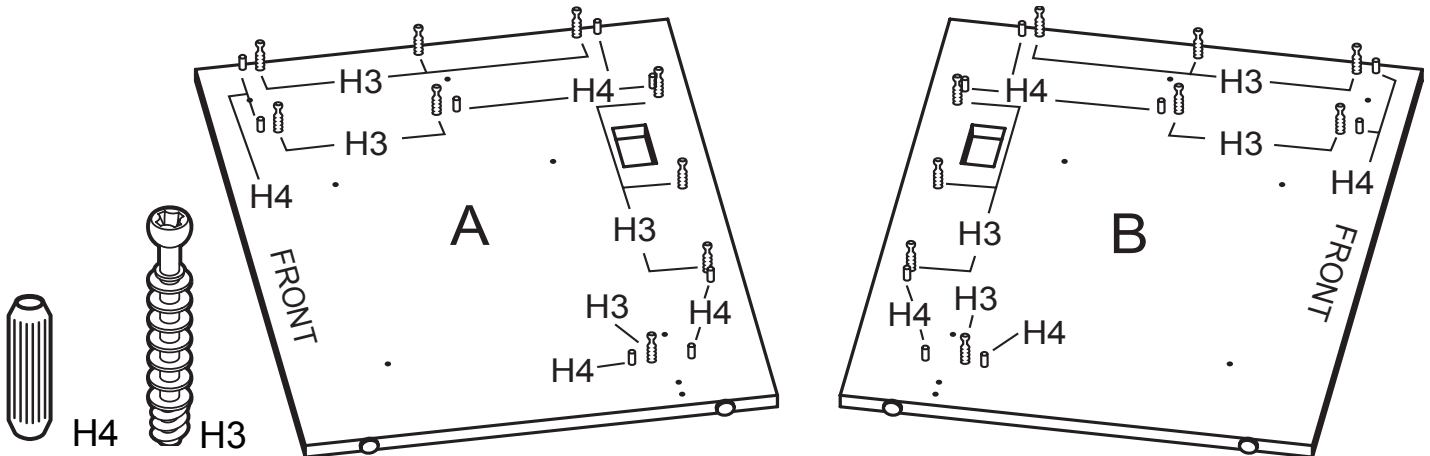
**#3**

Attach a Full Extension Slide (S1) to Left Side (A) using two Varianta Screws (H5) as shown.

Note: It will be necessary to slide the sliding portion forward to access the 1st hole.

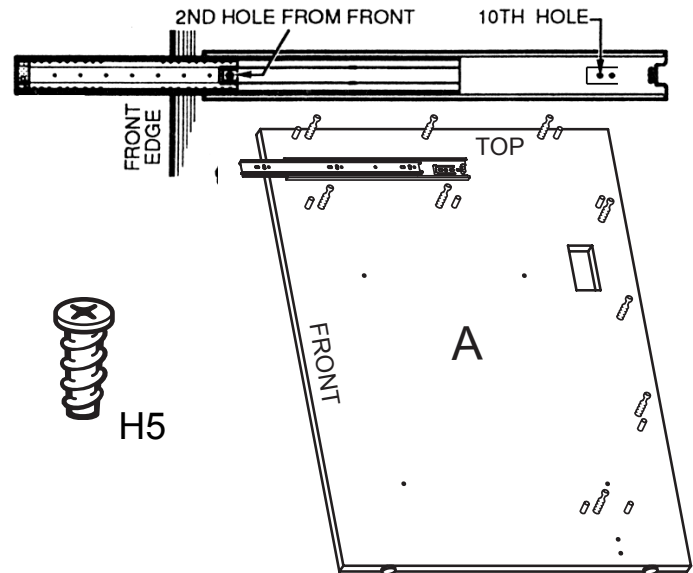
**#4**

Attach a Full Extension Slide (S1) to the Right Side (B) using two Varianta Screws (H5) as shown.

Note: It will be necessary to slide the sliding portion forward to access the 1st hole.

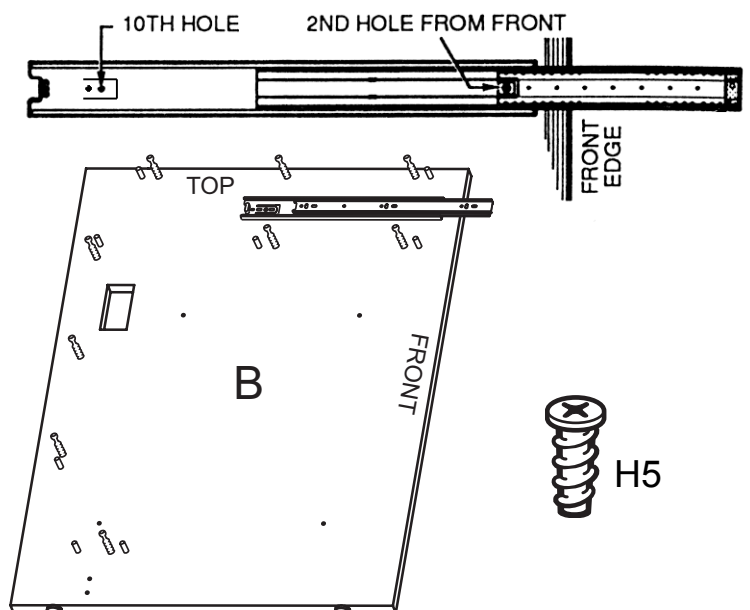

#5

Attach a Full Extension Slide (S1) to the right side of the Divider (J) using two Varianta Screws (H5) as shown.

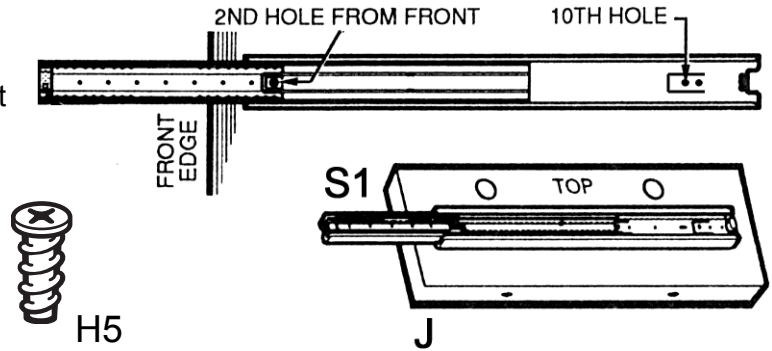

#6

Attach a Full Extension Slide (S1) to the left side of the Divider (J) using two Varianta Screws (H5) as shown.

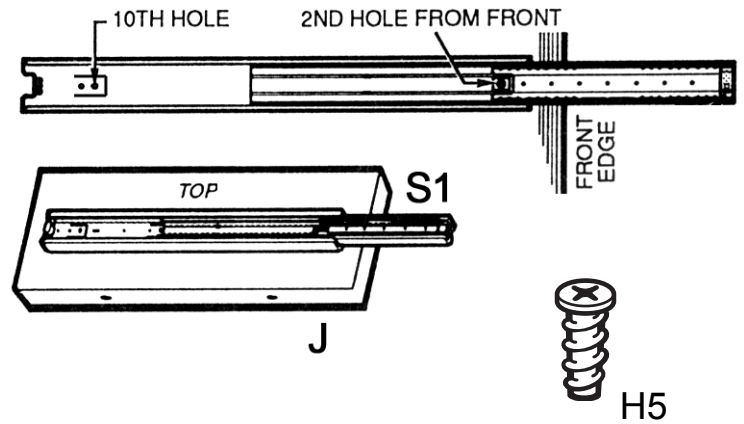

#7

Insert six Minifix Cams (H6) into the Top (C) with the arrows of the cams facing out.

Attach two Lock Stops (H7) to the Top using #6x5/8" Panhead Screws (H8) as shown.

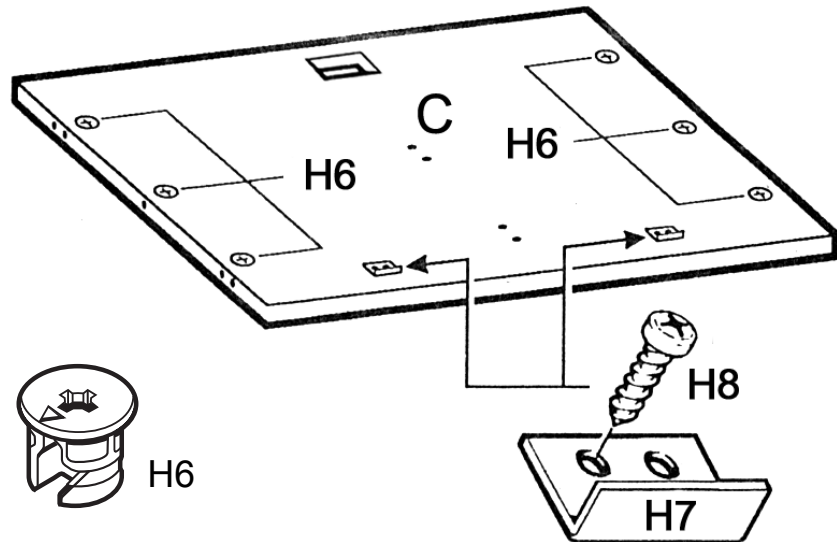

#8

Screw two Minifix Bolts (H3) and insert two Dowels (H4) into the Top (C) where indicated.

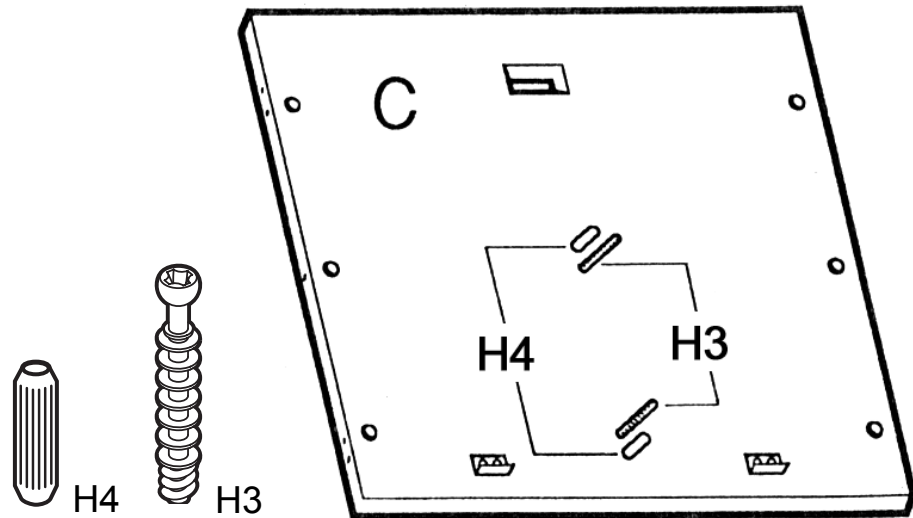

#9

Insert Minifix Cams (H6) into the Divider (J) with the arrows of the cams facing out.

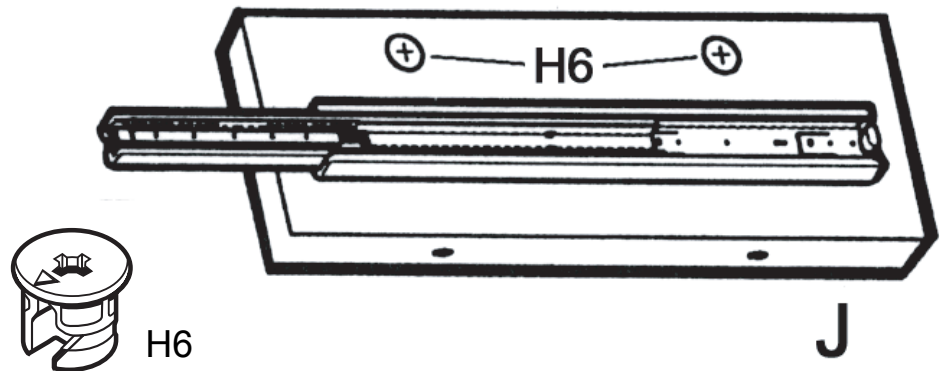

#10

Position the Divider (J) onto the Top (C) and turn the cams clockwise to secure.

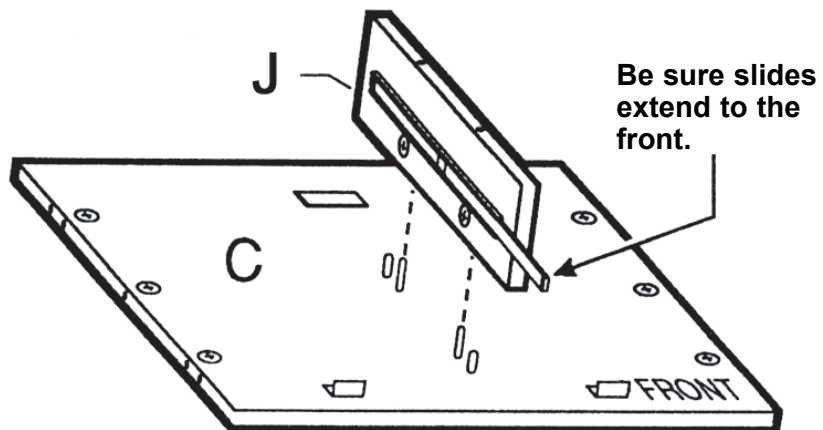

#11

Insert Minifix Cams (H6) where indicated into the Back (D) and the Shelf (G) with the arrows of the cams facing out.

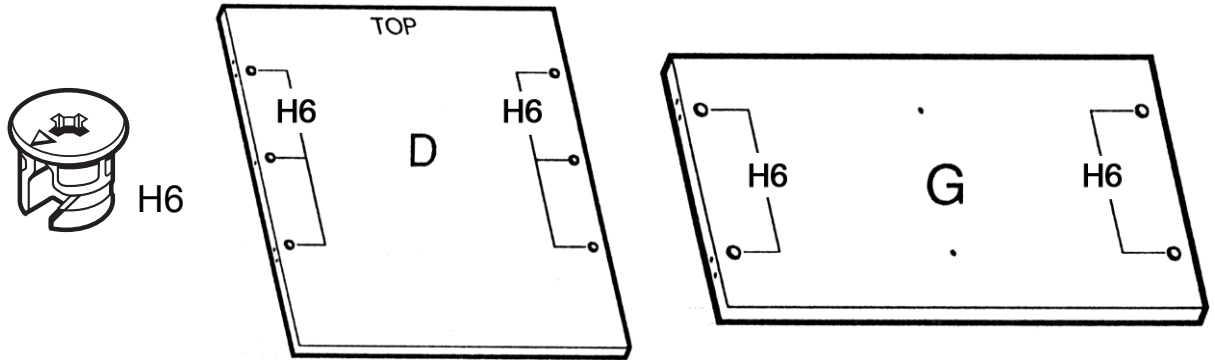

#12

Secure an Angle Bracket (H9) to each end of the Toeboard (F) using the Panhead Screws (H10).

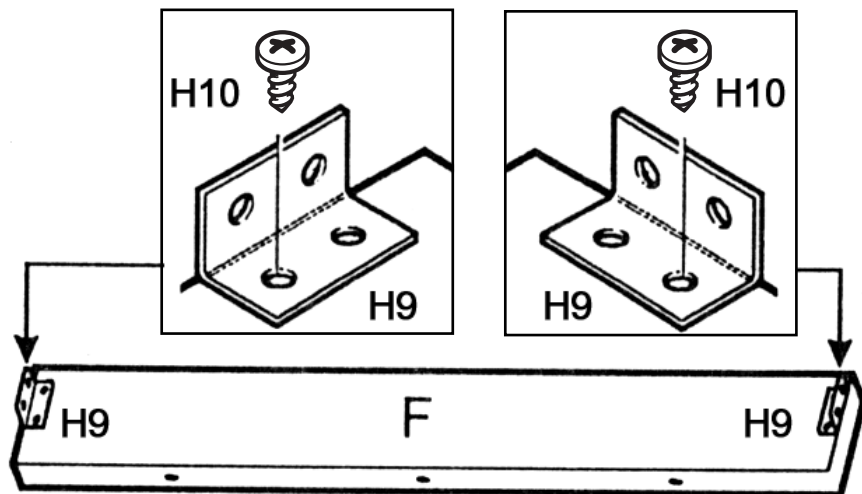

#13

Insert two Minifix Cams (H6) into the Bottom (E) with the arrows facing out.



#14

Attach the Toeboard (F) to the Bottom (E) using three Confirmat Screws (H11) through the pre-drilled holes as shown.

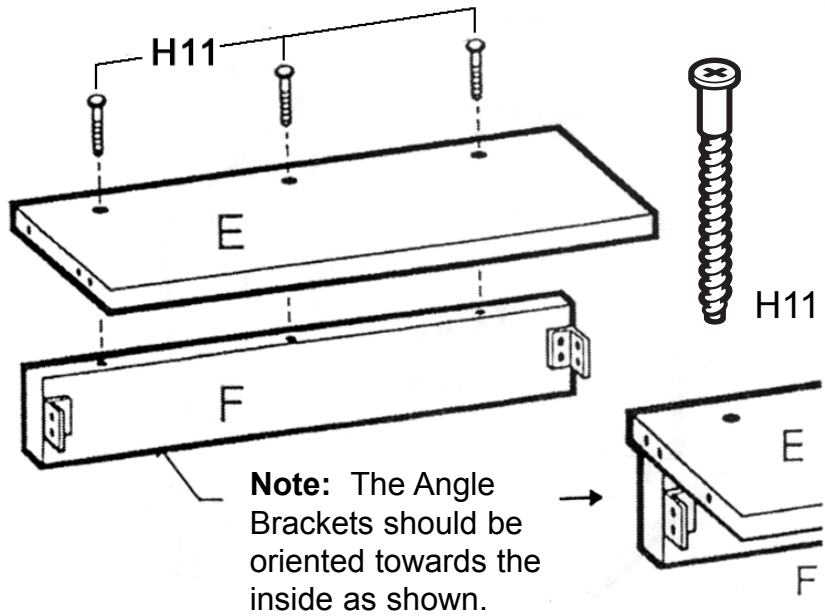

#15

Position the Top (C) and Divider (J) assembly onto the Left Side (A). Turn the cams (H6) clockwise to secure.

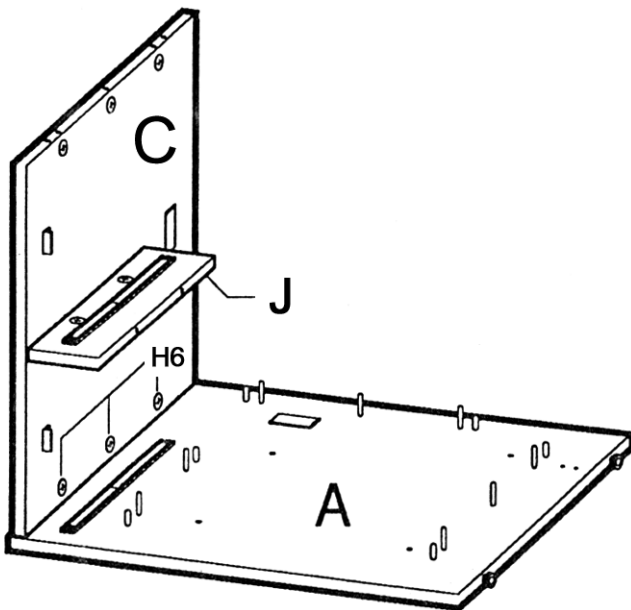

#16

Position the Back (D) onto the Left Side (A) and turn cams (H6) clockwise to secure.

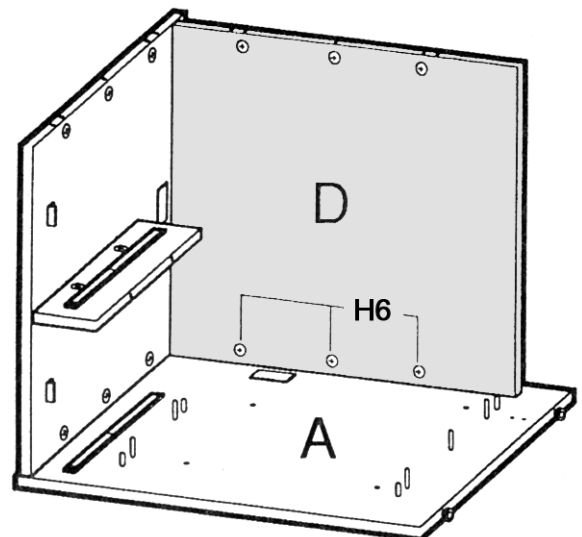

#17

Position the Top Shelf (G) onto the Left Side (A) and turn cams (H6) clockwise to secure.

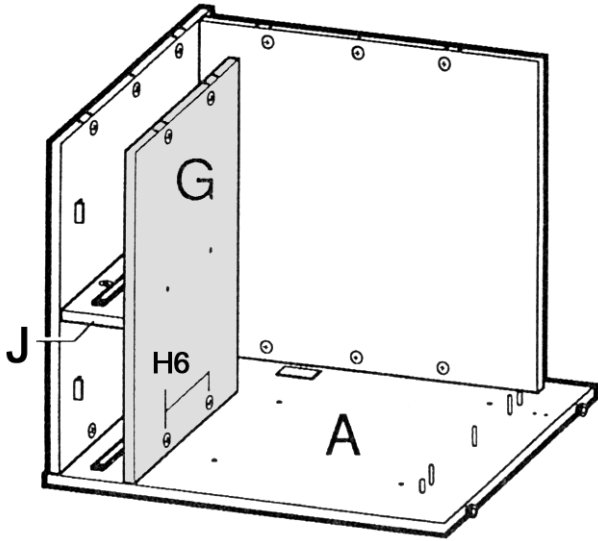
**#18**

Attach the Top Shelf (G) to Divider (J) using two Confirmat Screws (H11) through the pre-drilled holes.

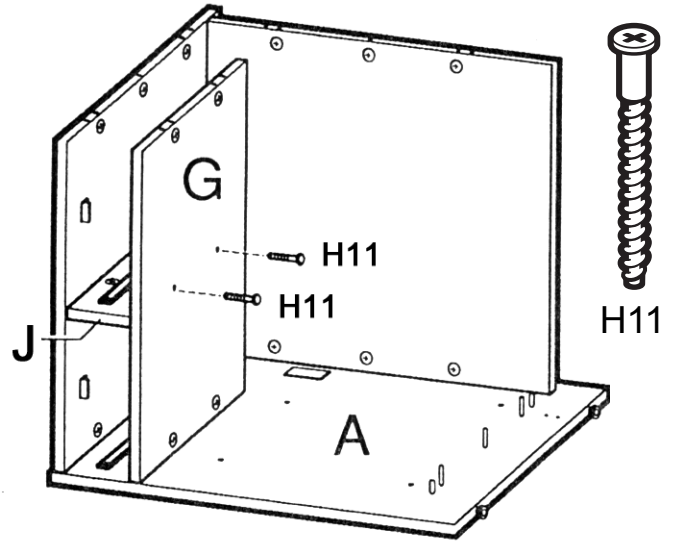
**#19**

Position the Toeboard and Bottom assembly (F & E) onto the Left Side (A) and turn the cam (H6) to secure.

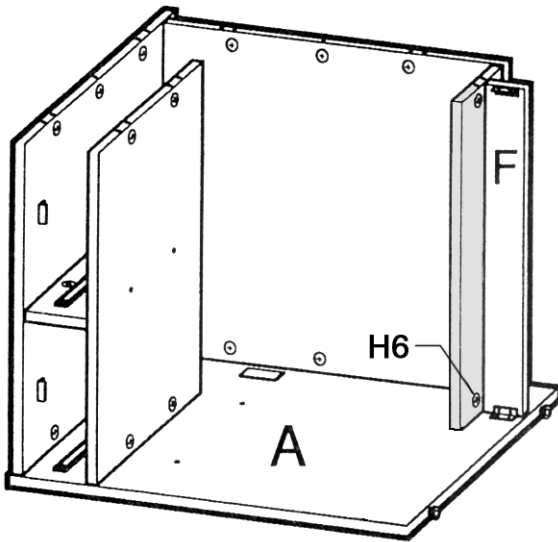
**#20**

Position the bolts and dowels of the Right Side (B) onto the unit and turn cams (H) clockwise to lock in place.

You can use the Hex Wrench (H23) to tighten the cams on the Top Panel (C).

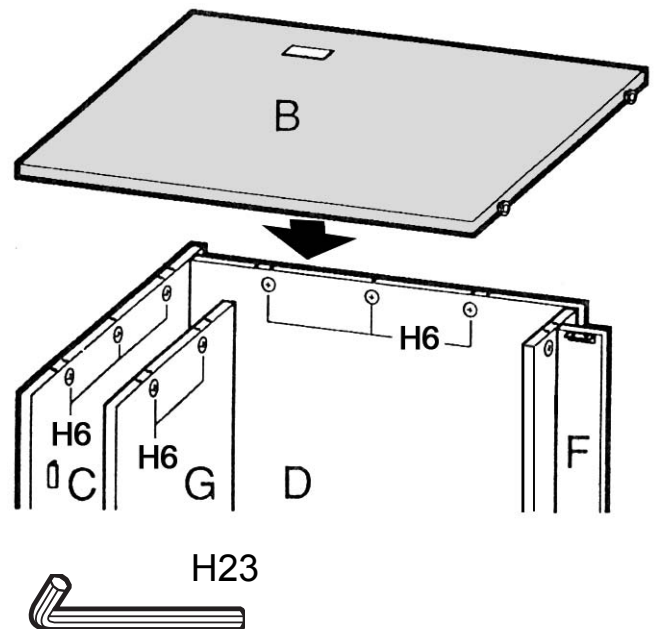

#21

Secure the Angle Brackets (H9) of the Toeboard (F) to the Left Side (A) and Right Side (B) using #14x1/2" Panhead Screws (H10).

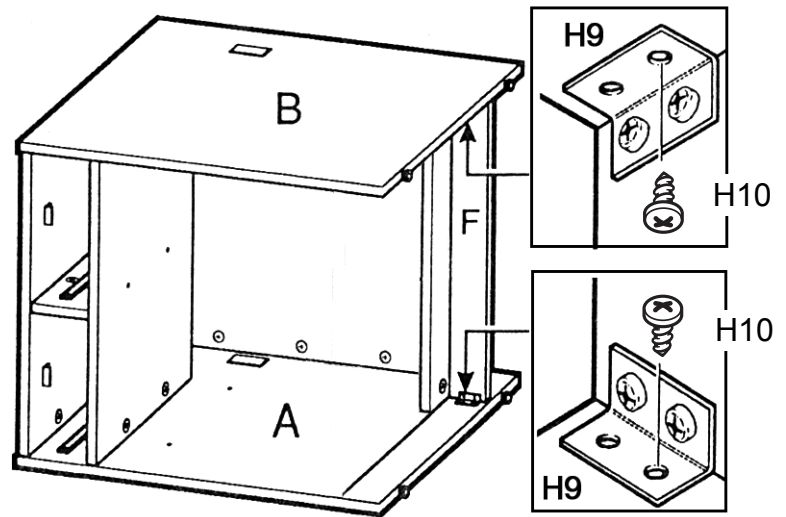

#22

Apply glue (H19) to the edges of the Drawer Ends as shown. Use four Confirmat Screws (H11) to attach Drawer Side (D1) to Drawer Ends (D2) with the grooves aligned on the inside as shown.

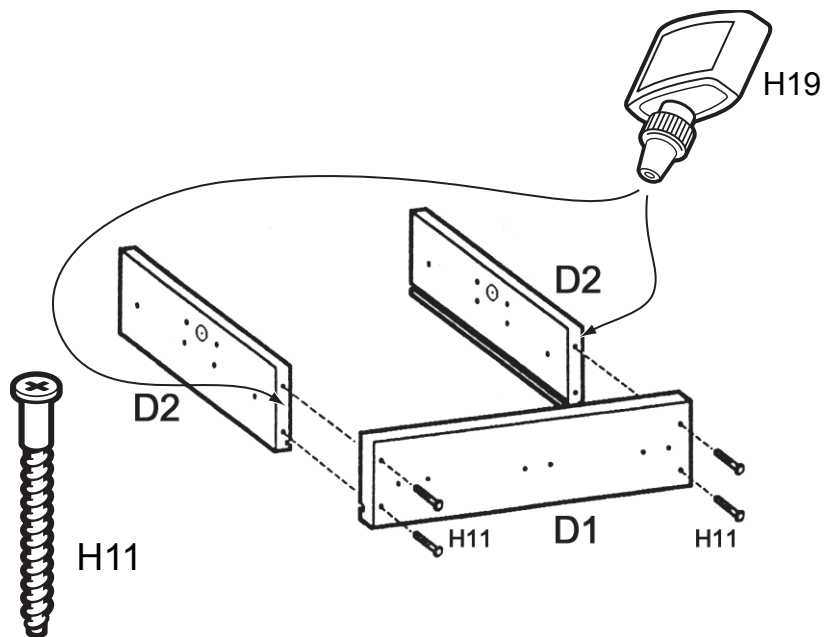

#23

Apply glue (H19) to three edges of the Drawer Bottom (D5) as shown. Slide the Drawer Bottom (D5) into the grooves of the Drawer Ends (D2) until seated in the Drawer Side (D1) groove.

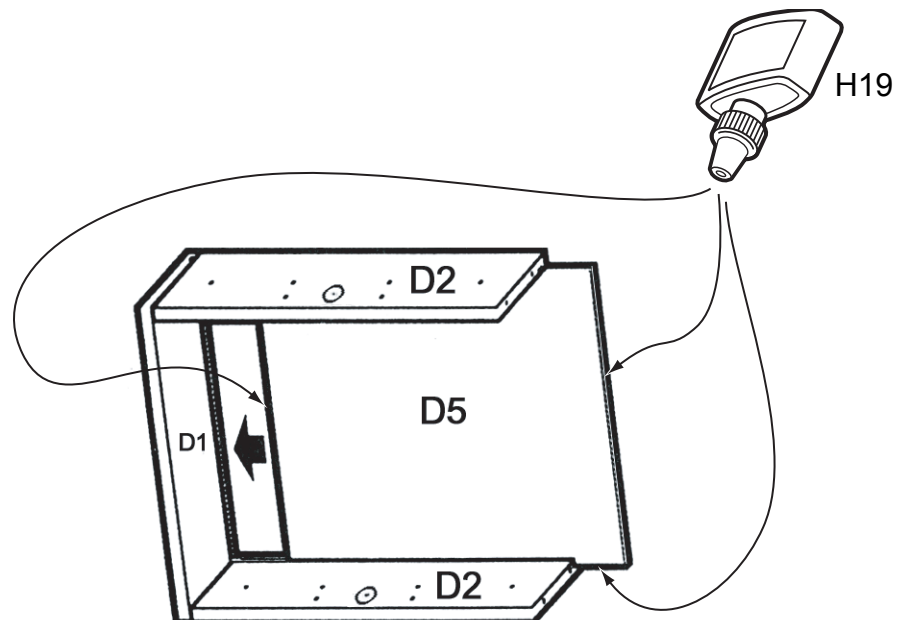

#24

Apply glue (H19) to the exposed edge of the Drawer Bottom (D5) and the Drawer Ends (D2). Position the other Drawer Side (D1) onto unit with the groove aligned with the edge of the bottom.

Secure the Drawer Side to the Drawer Ends using four Confirmat Screws (H11).

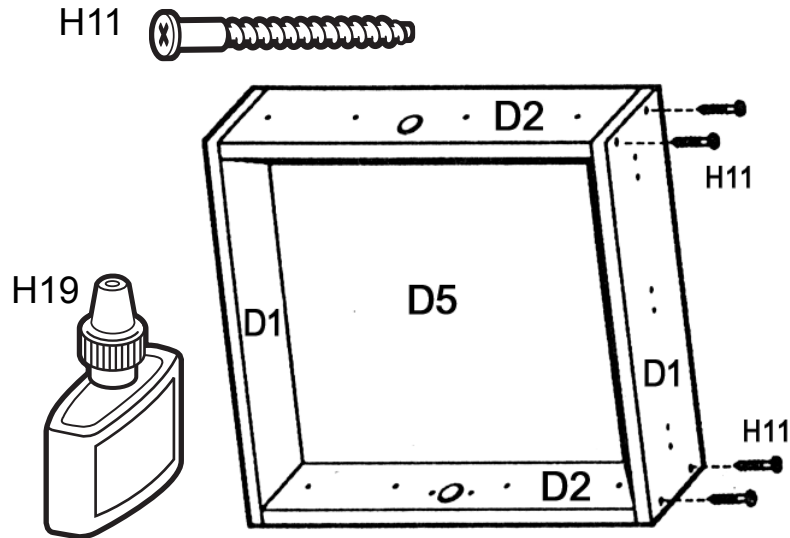

#25

Attach the Drawer Front (L) to the Drawer assembly using two Washerhead Screws (H12).

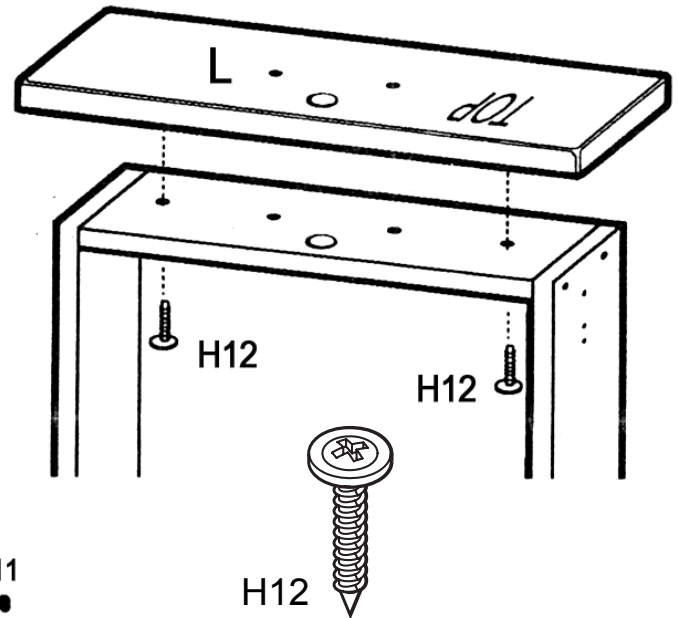

#26

Insert the Cam Lock (H13) through the holes in the Drawer End (D2) and Drawer Front (L) and secure in place using #6x5/8" Flathead Screws (H14) as shown.

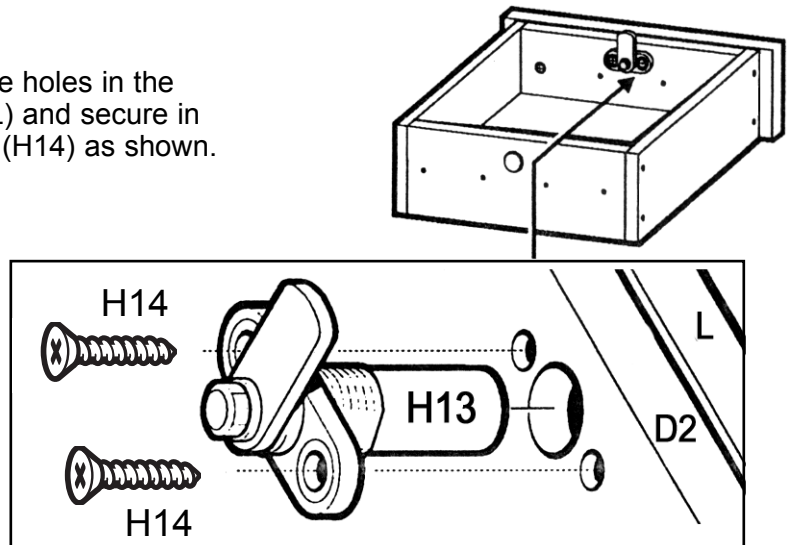

#27

Insert a Bezel (H15) into the front of the Drawer Front (L) and press into place over the Cam Lock (H13) as shown.

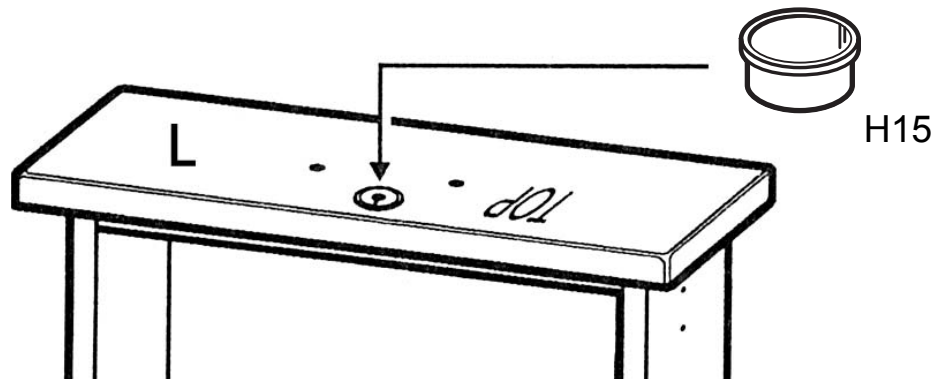

#28

Attach a Drawer Handle (H6) to the Drawer Front (L) as shown using two 1-1/2" Washerhead Screws (H17).

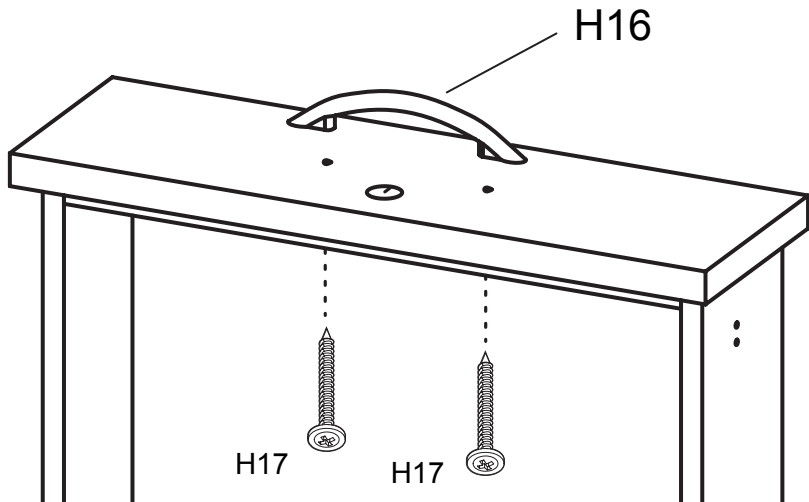
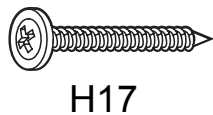

#29

You must disassemble the the Full Extension Slide before proceeding to the next step.

The Full Extension Slides (S1) consist of the main slide sections and the channel sections. The four slides were installed on Sides A and B and on both sides of the Divider (J). To disassemble the slides, extend the slide completely. Push the long arm of the locking clip up (or down) and pull the channel section forward until disconnected as shown.

Note: The long arm of the locking clip will either be on top or on the bottom of the channel, depending on which side it is installed.

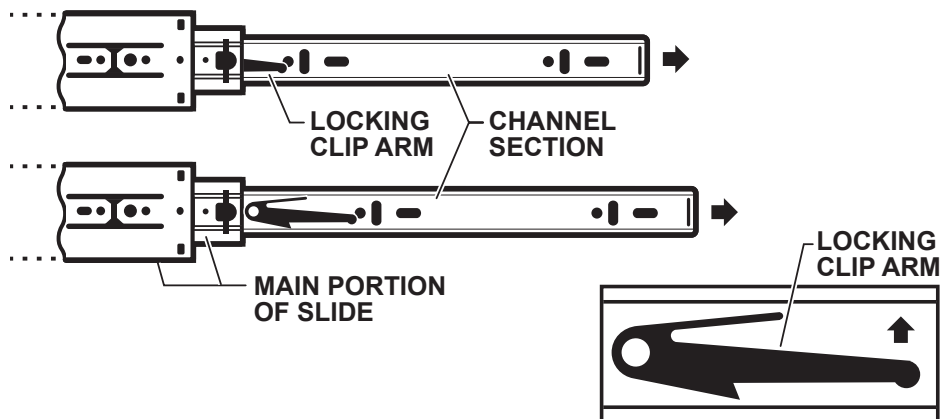

#30

Attach a channel portion of the Full Extension Slide (S1) to the left side of **both** drawer assemblies using #6 x 3/8" Panhead Screws (H18) as shown.

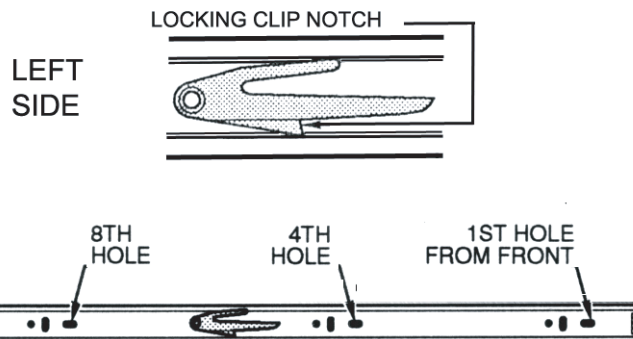
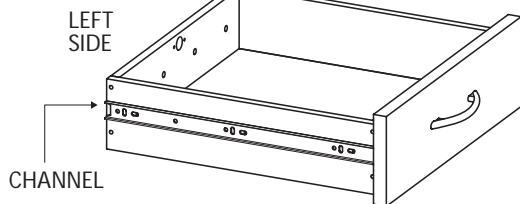

#31

Attach a channel portion of the Full Extension Slide (S1) to the right side of **both** drawer assemblies using #6x3/8" Panhead Screws (H18) as shown.

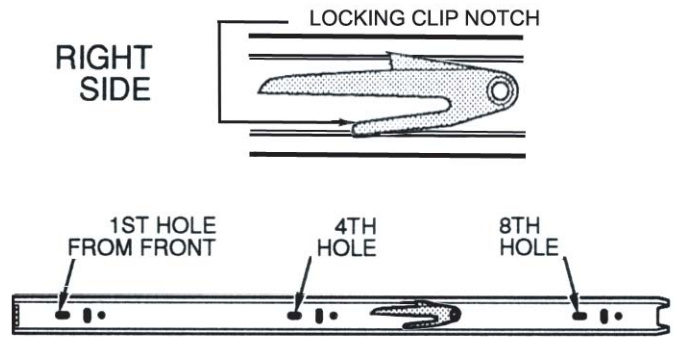
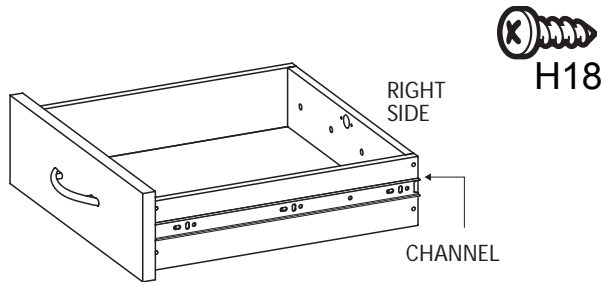

#32

Assemble the second Drawer unit in the same manner. Extend cabinet portions of the Full Extension slides completely out. Slide the channels of the drawer units onto the slides of the cabinet as shown until secured by the locking clips.

Check Drawer Fronts (L) for even spacing and alignment. If adjustment is necessary, loosen Washerhead Screws (H12) and Long Machine Screws (H17) slightly, reposition Drawer Fronts, and retighten screws.

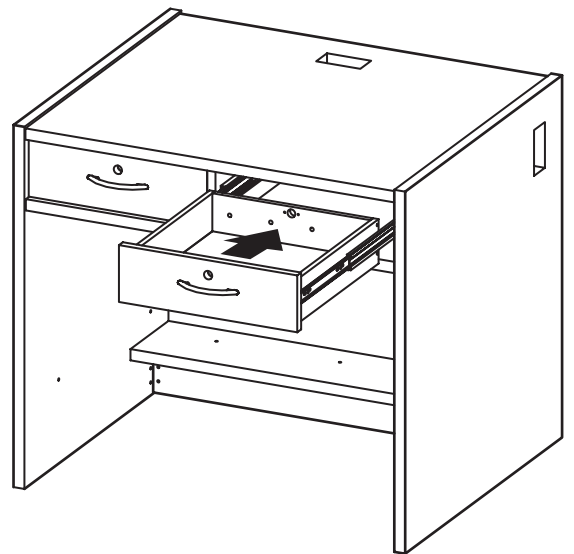

#33

Insert Grommets (H20) into the Left Side (A), Right Side (B), and Top (C).

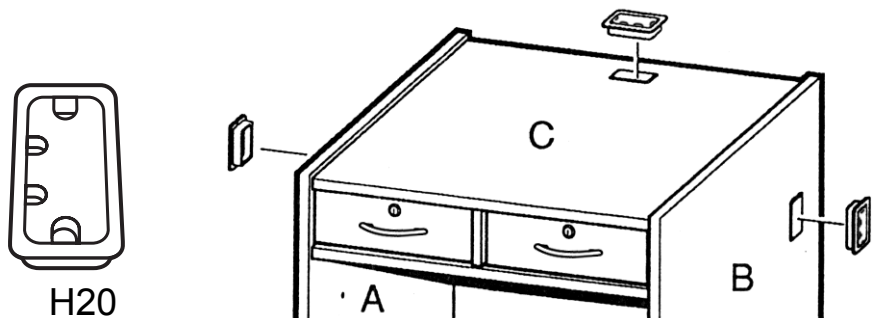

Your Glacier Two Drawer unit is now fully assembled and ready for use.

CONNECTING TO OTHER CIRCULATION DESK UNITS

Remove Grommets from the panels to be connected.

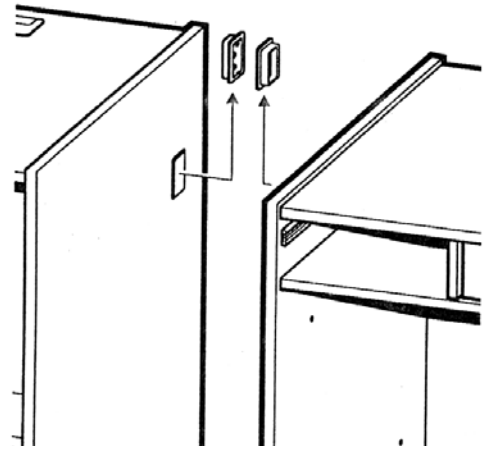

Using a 13/64" bit, drill through the four pilot holes on the inside of each side panel.

Align the side panels of the units to be connected. Tap four Connector Sleeves (H21) through the holes in one side panel and into the holes of the unit to be connected. From the other side, secure the units together using four Connector Screws (H22).

