



# Haws®

## AXION® MSR Corrosion Resistant Shower and Eye/Face Wash

# model 8336

### FEATURES & BENEFITS

#### CONSTRUCTION

2-1/2" green epoxy finished Schedule 80 PVC pipe stanchion offer an added protection in highly corrosive environments.

#### QUALITY CONTROL

Entire unit is pre-built and pressure tested to ensure a leak free installation.

#### VALVES

Type 316 Stainless Steel eyewash and shower ball valves are designed to make the flushing of fluid occur with the simple pull of a lever or push of a stainless steel flag, and come equipped with a stainless steel ball and stem to provide greater protection against corrosion and breakage.

#### SHOWER HEAD

AXION® MSR ABS plastic drench showerhead uses a hydrodynamic design to give equal distribution of water throughout the entire footprint of flow.

#### EYE/FACE WASH

AXION® MSR eye/face wash head (patent pending) uses an inverted directional laminar flow to sweep contaminants away from the vulnerable nasal cavity.

### OPTIONS

- ❑ Test Tag: SP170 is a green waterproof test card with space for date and initials of inspector. Used to record weekly testing of emergency equipment.
- ❑ Large Shower/Eyewash Sign: Model SP178LG large vertical universal combination emergency shower and eyewash sign. Size: 18" x 24" (45.7 x 61 cm).
- ❑ AXION® MSR Showerhead: Model SP829SS, AXION® MSR stainless steel drench showerhead with integral 20 gpm (75.7 L) flow control.
- ❑ Thermostatic Mixing Valve: Model 9201E AXION® Emergency Tempering Valve thermostatically mixes hot and cold water to provide a safe fluid supply for emergency showers and eyewash equipment, with a flow rate of 31 gpm (117.3 L).

For more information, visit [www.hawsc.com](http://www.hawsc.com) or call (888) 640-4297.



### SPECIFICATIONS

Model 8336 corrosion-resistant PVC plastic combination shower and eye/face wash shall include an AXION® MSR eye/face wash head shall feature inverted directional laminar flow which achieves Zero Vertical Velocity™ supplied by an integral 3.7 gpm flow control. Unit shall also include the AXION MSR hydrodynamic designed ABS plastic showerhead with 20 gpm flow control. The unit shall also include an ABS plastic 11" (27.9 cm) round bowl, stainless steel shower and eyewash ball valves equipped with stainless steel ball and stem, green epoxy finish, schedule 80 PVC 2 1/2" floor flange, schedule 80 PVC plastic vertical piping, universal sign, 1-1/4" IPS supply, and 1-1/2" slip waste.

### APPLICATIONS

Where the eyes, or body of any person may be exposed to injurious or corrosive materials, suitable facilities for quick drenching or flushing of the eyes and body shall be provided within the work area for immediate emergency use. Emergency eyewash facilities and deluge showers shall be in unobstructed and accessible locations that require no more than 10 seconds for the injured person to reach. Model 8336 is certified by CSA to meet the ANSI Z358.1 Standard for Emergency Eyewash and Shower Equipment.



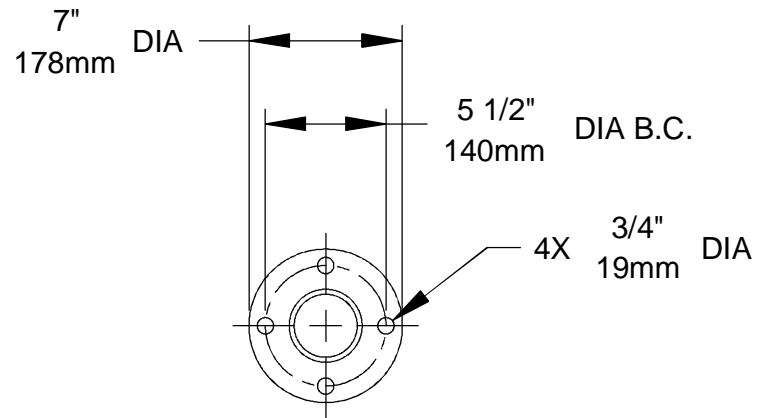
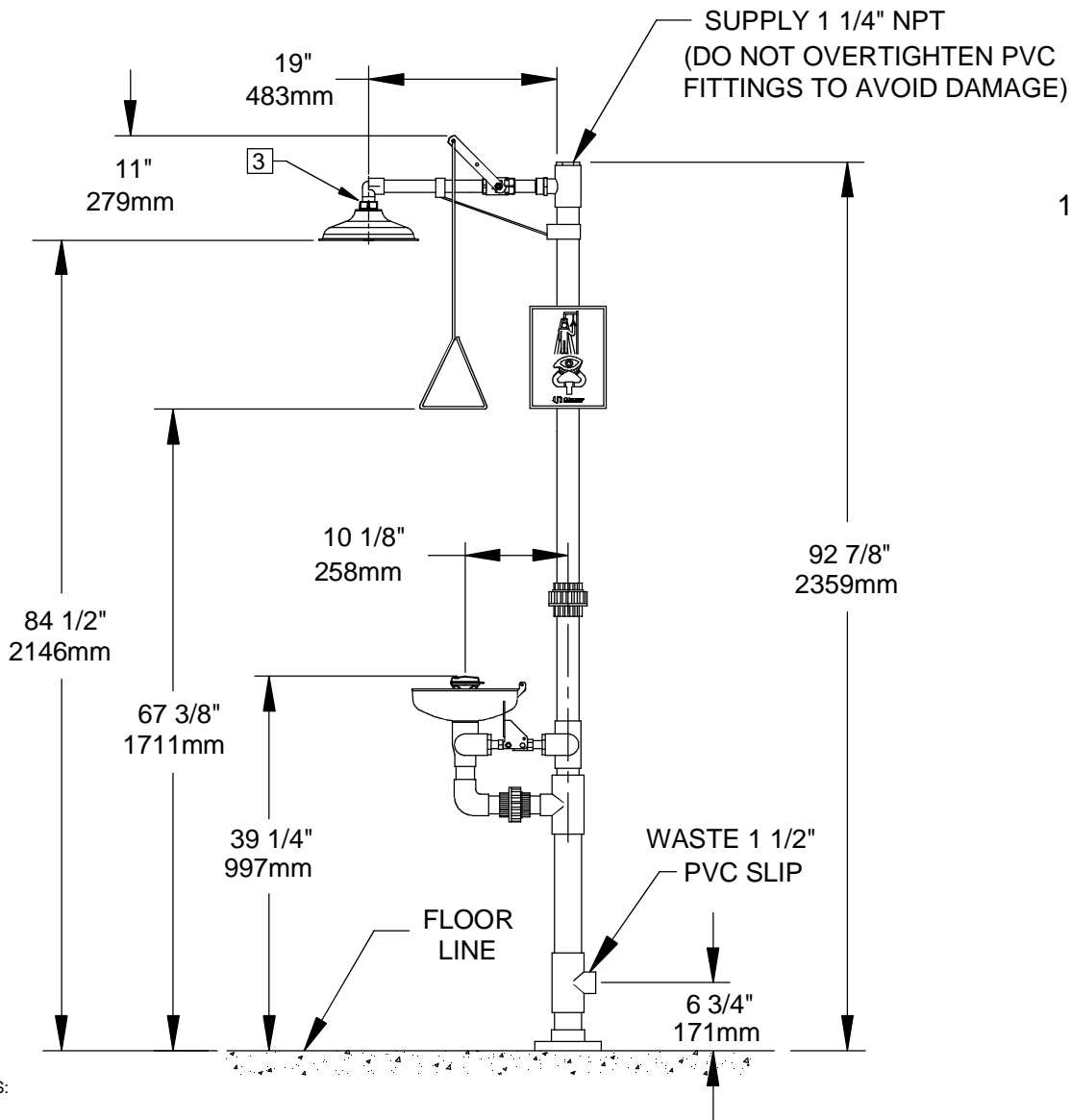

## MOUNTING PATTERN

**NOTES:**

1. DIMENSIONS MAY VARY BY  $\pm 1/2$  INCH [13mm].
2. TO COMPLY WITH ANSI Z358.1-2014 FOR EMERGENCY EYEWASH OR EYE/FACE WASH AND SHOWER EQUIPMENT:
  - UNIT SHALL BE INSTALLED IN ACCORDANCE WITH MANUFACTURER'S INSTRUCTIONS AND ACCEPTABLE PLUMBING PRACTICES.
  - EYEWASH OR EYE/FACE WASH SHALL BE POSITIONED WITH NOZZLES NOT LESS THAN 83.8 CM (33 IN.) AND NO GREATER THAN 114.3 CM (45 IN.) FROM SURFACE ON WHICH USER STANDS AND 15.3 CM (6 IN.) MINIMUM FROM WALL OR NEAREST OBSTRUCTION.
  - SHOWER SHALL BE POSITIONED SO THAT SHOWER HEAD IS NOT LESS THAN 208.3 CM (82 IN.) NOR MORE THAN 243.8 CM (96 IN.) FROM SURFACE ON WHICH USER STANDS.
  - SHOWER SPRAY PATTERN SHALL HAVE A MINIMUM DIAMETER OF 50.8 CM (20 IN.) AT 152.4 CM (60 IN.) ABOVE SURFACE ON WHICH USER STANDS, AND CENTER OF SPRAY PATTERN SHALL BE LOCATED AT LEAST 40.6 CM (16 IN.) FROM ANY OBSTRUCTION.

[3] DO NOT USE REGULAR PIPE SEALANT. IF NECESSARY USE DOW CORNING 832 SEALANT PLACING 5 SMALL BEADS ON THE MALE THREADS, JUST ABOVE THE FIRST THREAD.

		1455 KLEPPE LANE SPARKS, NEVADA 89431 (775) 359-4712 FAX (775) 359-7424 E-MAIL: HAWS@HAWS.CO.COM WEBSITE: WWW.HAWS.CO.COM	
		ECN NO. REVISED PER BY: HM ECN: 4976	MODEL(S) 8336 CORROSION RESISTANT COMBO UNIT
DRAWN: g. hayes APPROVED: FV	DATE: 01/01 DATE: 10/21/15	CHK'D.: VWC	SCALE: 1:18 DRAWING TYPE: INSTALLATION SIZE: A SHEET 1 OF 1