



# INSTALLATION, OPERATION & MAINTENANCE INSTRUCTIONS

1455 Kleppe Lane ♦ Sparks, NV 89431-

6467 ♦ (775) 359-4712 ♦ Fax (775) 359-7424

E-mail: [haws@hawsco.com](mailto:haws@hawsco.com) ♦ website: [www.hawsco.com](http://www.hawsco.com)

No. 0510001018 (2)

## Model 8315CTFP (120V) & 8315CTFP.220V

**NOTE TO INSTALLER: Please leave this information with the Maintenance Department.**

### LIMITED WARRANTY

HAWS warrants that this specific product is guaranteed against defective material or poor workmanship for a period of **one year from date of shipment**. HAWS liability under this warranty shall be discharged by furnishing without charge F.O.B. HAWS Factory any goods, or part thereof, which shall appear to the Company upon inspection to be of defective material or not of first class workmanship, provided that claim is made in writing to Haws within a reasonable period after receipt of the product. Where claims for defects are made, the defective part or parts shall be delivered to the Company, prepaid, for inspection. HAWS will not be liable for the cost of repairs, alterations or replacements, or for any expense connected therewith made by the owner or his agents, except upon written authority from HAWS, Sparks, Nevada. HAWS will not be liable for any damages caused by defective materials or poor workmanship, except for replacements, as provided above. Buyer agrees that Haws has made no other warranties either expressed or implied in addition to those above stated, except that of title with respect to any of the products or equipment sold hereunder and that HAWS shall not be liable for general, special, or consequential damages claimed to arise under the contract of sale.

The emergency equipment manufactured by HAWS is warranted to function if installation and maintenance instructions provided are adhered to. The units also must be used for the purpose for which they were intended. This product is intended to supplement first-aid treatment. Due to widely varying conditions, Haws cannot guarantee that the use of this emergency equipment will prevent serious injury or the aggravation of existing or prior injuries.

**NO OTHER WARRANTIES EXPRESSED OR IMPLIED ARE AUTHORIZED, PROVIDED OR GIVEN BY HAWS.**

**SHOULD YOU EXPERIENCE DIFFICULTY WITH THE INSTALLATION OF THIS MODEL PLEASE CALL:**

**TECHNICAL SUPPORT: 1-800-766-5612**

**FOR CUSTOMER SERVICE: 1-888-640-4297**

**RECOMMENDED TOOLS & SUPPLIES:**

- Pipe wrenches (both with teeth and smooth jaws)
- Power drill with #2 Phillips bit (preferred), or #2 Phillips screwdriver (preferably ratcheting)
- Adjustable wrench (or a standard wrench set up 7/8")
- 7/32" hex key
- Level
- Three (3) rust-resistant anchors (3/8" diameter)
- Pipe joint sealant (Loctite PST #567 recommended)
- Silicone caulking (Dow Corning 832 recommended)
- Stepladder

**LOCATION OF UNIT:**

- The Model 8315CTFP (120V) & 8315CTFP.220V Emergency Shower Eye/Face Wash should be installed in close proximity to potential accident areas. It should be clearly identified, free from obstructions, and easy to access.
- Suitable for use in Class 1, Division 2 Group B,C,& D areas.
- Temperature rating T6 (85°C).

**ELECTRICAL SUPPLY: During potentially freezing periods, ensure that unit is connected to a continuous power supply.**

- **MODEL 8315CTFP:** Electrical power required for standard heat traced unit is 120 VAC. Average power consumption at 50°F (10°C) ambient temperature is 110 watts. Maximum without lighting is 130 watts. Connection at input junction box is 3/4" NPT.
- **MODEL 8315CTFP.220V:** Electrical power required for standard heat traced unit is 220 VAC. Average power consumption at 50°F (10°C) ambient temperature is 110 watts. Maximum without lighting is 130 watts. Connection at input junction box is 3/4" NPT.

**WATER SUPPLY: Water supply must be freeze protected.**

- The minimum recommended line is 1-1/4" IPS with 30-90 psi (2-6 ATM) flowing pressure.
- An inlet filter is recommended where sediment or mineral content is a problem.
- Main inlet connection is 1-1/4" IPS.
- Optional SP121 auxiliary outlet plumbing is 1-1/4" IPS.

**MAINTENANCE:**

- Allow eye/face wash piping to drain out completely before replacing eye/face wash dust cover.
- In freezing conditions, wipe eye/face wash head and dust cover dry after each use to prevent unwanted ice buildup.
- During regular testing, also verify these items:
  - Verify that both the eye/face wash and the shower are able to drain completely.
  - Verify that the dust cover is intact and firmly in place.
- Optional SP158.15 Freeze Protection Valve is a field serviceable item; refer to its manual for more information.

**WARNING: Fire and shock hazards – must use a ground fault electrical protection device (30mA GFEPD) for heat trace. Electrical fault currents may be insufficient to trip a conventional circuit breaker.**

# INSTALLATION PROCEDURE

Refer to the Installation Drawing for further details.

## STEP 1: Unboxing

The following components are included with this model. Note the locations within the packaging and the pertinent installation steps included for reference.

<p style="text-align: center;"><b><u>Top Tray</u></b></p> <p>6 plastic jacket components.....<i>Step 6</i></p>	<p style="text-align: center;"><b><u>Large Internal Carton</u></b></p> <p>Painted metal floor flange.....<i>Steps 2-3</i></p> <p>Plastic shower bell.....<i>Step 4</i></p> <p>6 lengths of seal trim.....<i>Step 6</i> <i>Note colored tape</i></p> <p>Universal shower sign.....<i>Step 9</i></p>
<p style="text-align: center;"><b><u>Small Internal Carton</u></b></p> <p>Piping connector.....<i>Step 3</i></p> <p>Piping union.....<i>Step 3</i></p> <p>6 large zip ties.....<i>Steps 3 &amp; 5</i></p> <p>2 piping elbows.....<i>Step 4</i></p> <p>Bag</p> <ul style="list-style-type: none"> <li>• Eye/face wash assembly.....<i>Step 7</i></li> </ul> <p>Bag</p> <ul style="list-style-type: none"> <li>• Metal shower lever.....<i>Step 7</i></li> <li>• Eyewash push flag.....<i>Step 7</i></li> <li>• Paper test tag.....<i>Step 9</i></li> </ul> <p>Bag</p> <ul style="list-style-type: none"> <li>• Plastic shower nozzle.....<i>Step 4</i></li> <li>• Plastic hole plug.....<i>Step 7</i></li> <li>• Plastic shower handle.....<i>Step 7</i></li> </ul> <p>Bag</p> <ul style="list-style-type: none"> <li>• Retaining ring.....<i>Step 4</i></li> <li>• Nut, shower lever.....<i>Step 7</i></li> <li>• Shower handle bolt.....<i>Step 7</i></li> <li>• Push flag nut.....<i>Step 7</i></li> <li>• 2 adhesive rubber covers.....<i>Step 7</i></li> <li>• 4 thread-forming screws.....<i>Step 9</i></li> <li>• Small zip tie.....<i>Step 9</i></li> </ul>	<p style="text-align: center;"><b><u>Central Area of Main Carton</u></b></p> <p>Factory-assembled section.....<i>Steps 3-9</i></p> <p>2 insulation tubing sections.....<i>Step 5</i></p>
	<p style="text-align: center;"><b><u>Bottom Area of Main Carton</u></b></p> <p>1-1/4" pipe nipple.....<i>Step 3</i></p> <p>2 1" pipe nipples.....<i>Step 4</i></p> <p>2 expanded foam support.....<i>Step 6</i> spacers for the horizontal shower piping</p> <p>Expanded foam support.....<i>Step 6</i> spacer for the vertical shower piping</p>

## STEP 2: Preparation

- a) Note the supply plumbing and electrical requirements.
  - Ensure that all above-ground supply or recirculation piping is protected with heat trace, insulation, and weather sealing (by others). If a flow switch is used, extend the heat trace and insulation 6" above the flow switch tee.
  - The small heat trace loop extending past the shower's supply plumbing should be secured to the piping as needed (zip ties by others) to provide good contact with the piping and to overlap the shower heat trace with the supply line heat trace.
- b) Prepare the foundation, locating three 3/8" anchors (not supplied) for the floor flange (see diagram). Locate these anchors so one is directly toward the front of the shower.

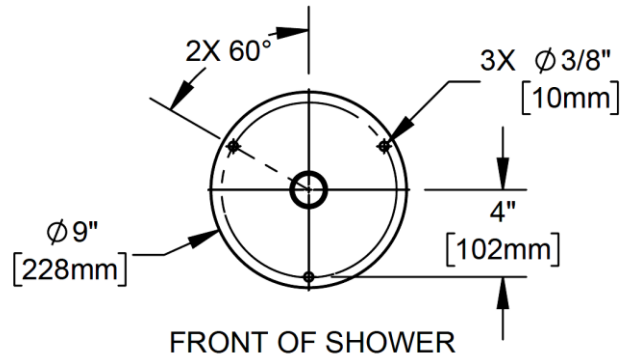

## STEP 3: Lower Support Stanchion

**Installation Tip:** The easiest way to build up this unit is likely to secure the floor flange to its anchors and assemble the piping from the ground up.

- a) Pull the right-side jacket from the factory-assembled section. There are two small pieces of seal trim holding the jacket on; these can be discarded.
- b) Assemble the dry lower support stanchion.
  - These threads must be tightened as normal, but do **NOT** need to be sealed.
  - Orient the floor flange so the hole in the upper half faces out the sides of the shower.
- c) Connect the shower supply to the supply water line.

**Important:** Flush supply lines to clear debris before connecting the shower.

**Important:** Do not allow any of the factory plumbing to rotate out of alignment during this step. If needed, hold the inlet piping (do not damage the heat trace) while installing piping to it.

- If helpful, use the optional union as shown.
  - If needed, apply one of the larger zip ties where the inlet plumbing exits the shower jacket, to create contact between piping and heat trace.
- d) Install any needed plumbed accessories. See those O&Ms and installation drawings.

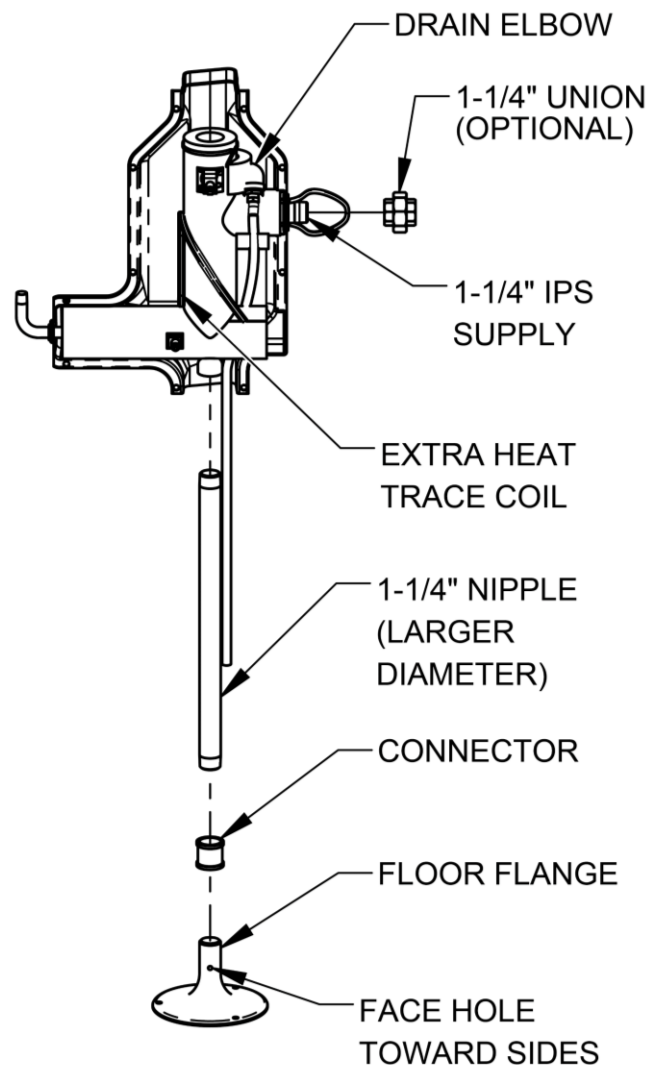

**Installation Tip:** For any plumbed accessories that require heat trace, this heat trace is secured to the front of the vertical piping above the eyewash.

#### STEP 4: Shower Piping

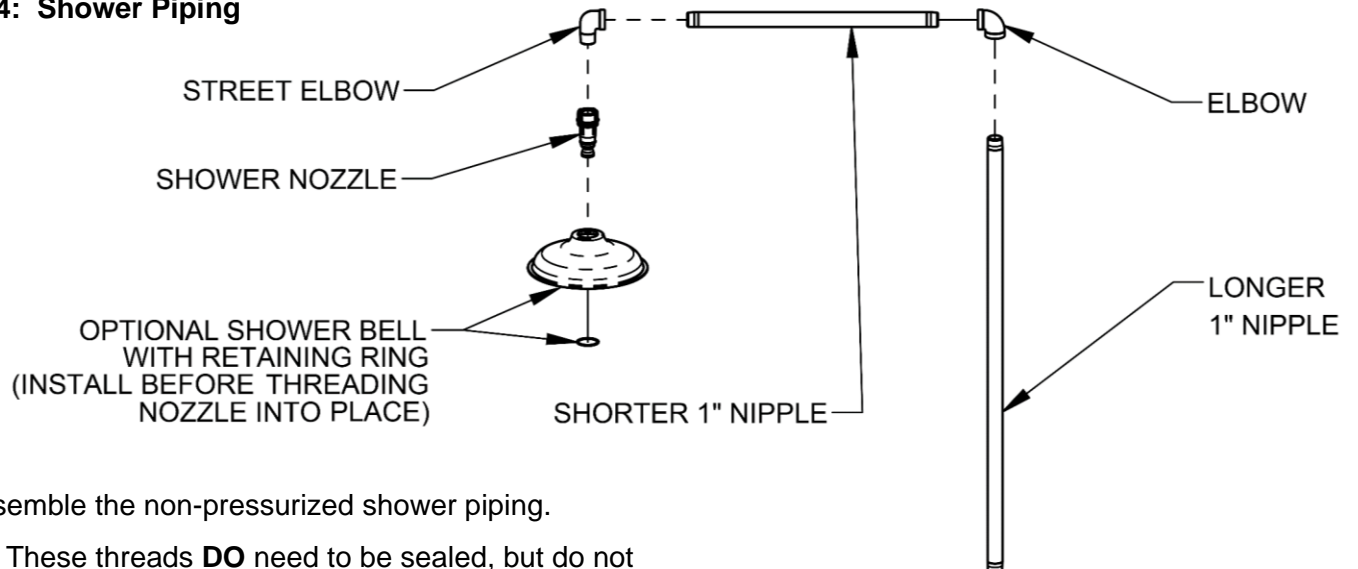

a) Assemble the non-pressurized shower piping.

- These threads **DO** need to be sealed, but do not overtighten.
- If needed, seal the shower nozzle connection with 5 small beads of Dow Corning 832 sealant on the male threads, just above the first thread.

**Important:** Do not allow any of the factory plumbing to rotate out of alignment during this step. If needed, hold the steel drain elbow at the back of the shower valve while installing piping to it.

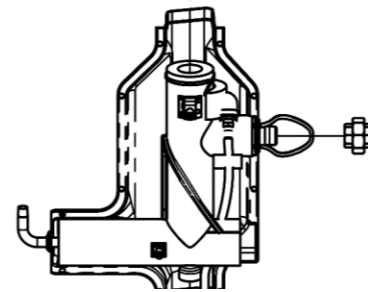

#### STEP 5: Insulation

a) Place the insulation tubing immediately above and below the factory insulation. Use **both** of the integral adhesive strips (one in the slit and one over the slit) to fully close each piece.

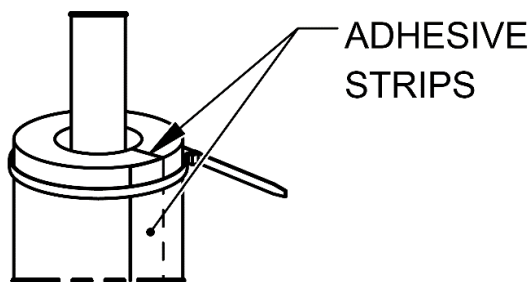

b) Use 5 larger zip ties to secure the insulation. Tighten each just enough to close the insulation around the pipe.

**Important:** Do not pinch the drain tubing with these.

**Installation Tip:** Locate each zip tie head to be in a back corner of the jacketing.

- Use 1 around each of the four ends of the new insulation pieces.
- Use 1 around the top of the factory insulation, above the shower valve.

c) Clip the white jacket supports onto the piping as shown.

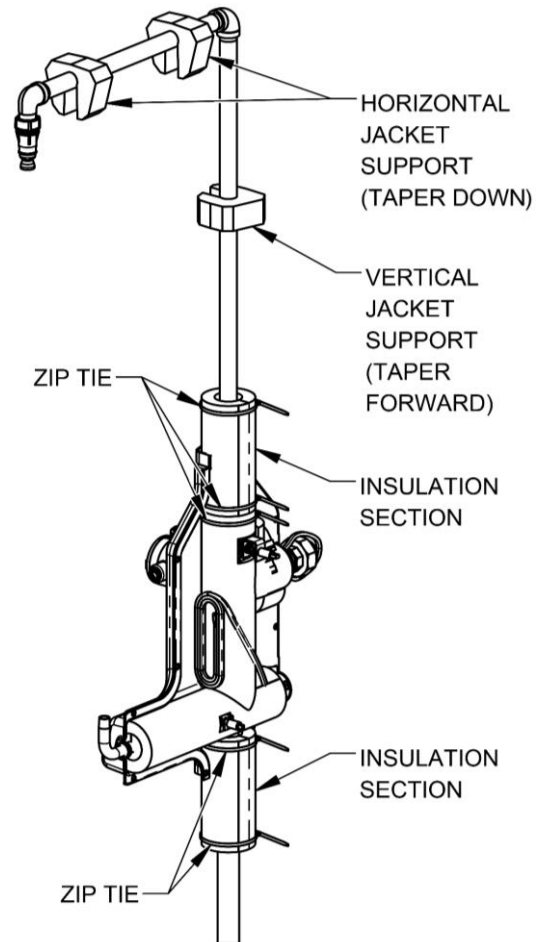

#### STEP 6: Jacketing

**WARNING:** Jacket edges may be sharp and could easily cut or puncture skin unless care is taken.

**Installation Tip:** Once a seal trim piece has been started on the jacket flanges, bend it sharply at a right angle and "roll" the seal trim onto the flanges. Ensure the seal trim is fully seated.

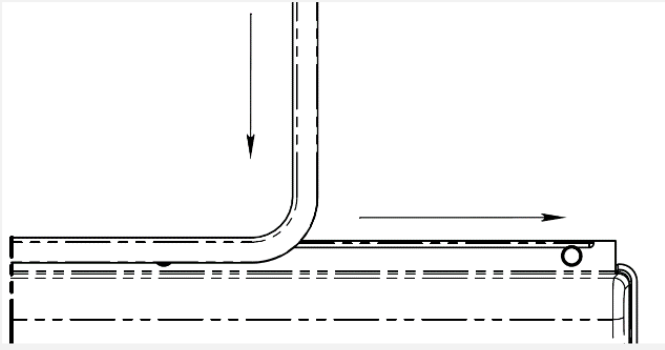

**Installation Tip:** Run the side of the seal trim with the single tooth on the side of the flanges with the holes.

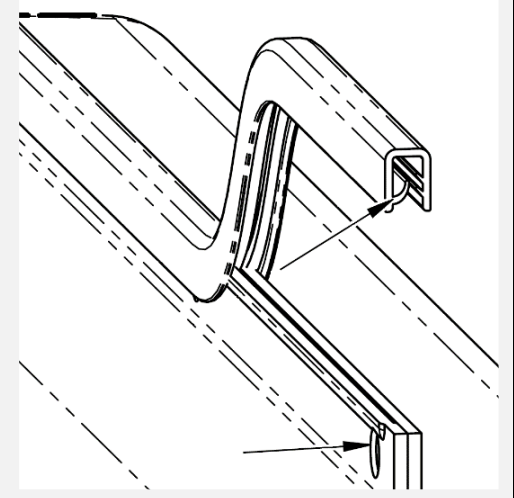

a) Factory-assembled jacket.

- Replace the right-side jacket, fitting it into all grommets and lining it up with all the mating flanges.

**Important:** Make sure the drain hole in the bottom of the plumbing beneath the eye/face wash is fully outside the jacketing.

- Press the short, unmarked seal trim piece onto the back flanges below the supply plumbing.

b) Lower jackets.

**Important:** Make sure the shower drain tubing does not kink, pinch, or let water to gather or pool. Make sure the tubing comes out the bottom of the jacketing.

- Slide the lower jackets fully into the opening in the factory jacketing above.
- Press the seal trim pieces marked with **red tape** and with **blue tape** into place where shown.

c) Upper vertical jackets.

- Slide the upper vertical jackets fully down onto the factory jacketing beneath. The white jacket support should help hold the jacketing in place.
- Press the seal trim marked with **white tape** onto the front flanges.

d) Top jackets.

- Overlap the top jackets onto the upper vertical jackets below. The white jacket supports should help hold the jacketing in place.

Press the seal trim pieces marked with **green tape** and with **yellow tape** into place where shown.

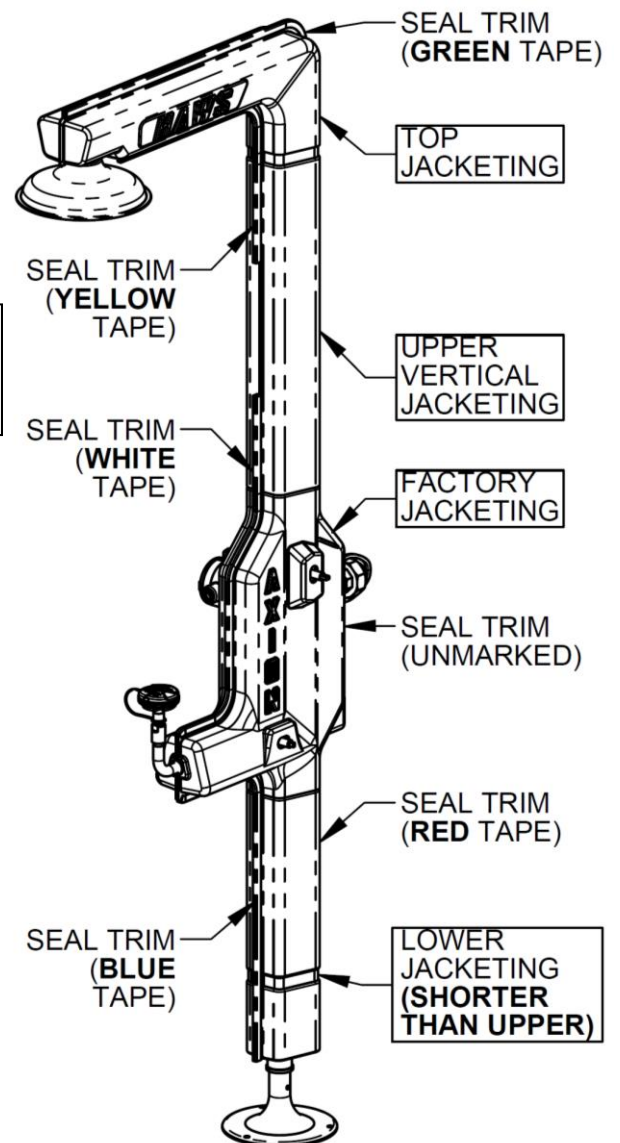

**STEP 7: User Controls**

- a) Shim the floor flange as needed to level the eye/face wash plumbing. If tilted backward, water could pool within and freeze, potentially reducing flow or impeding valve actuation.

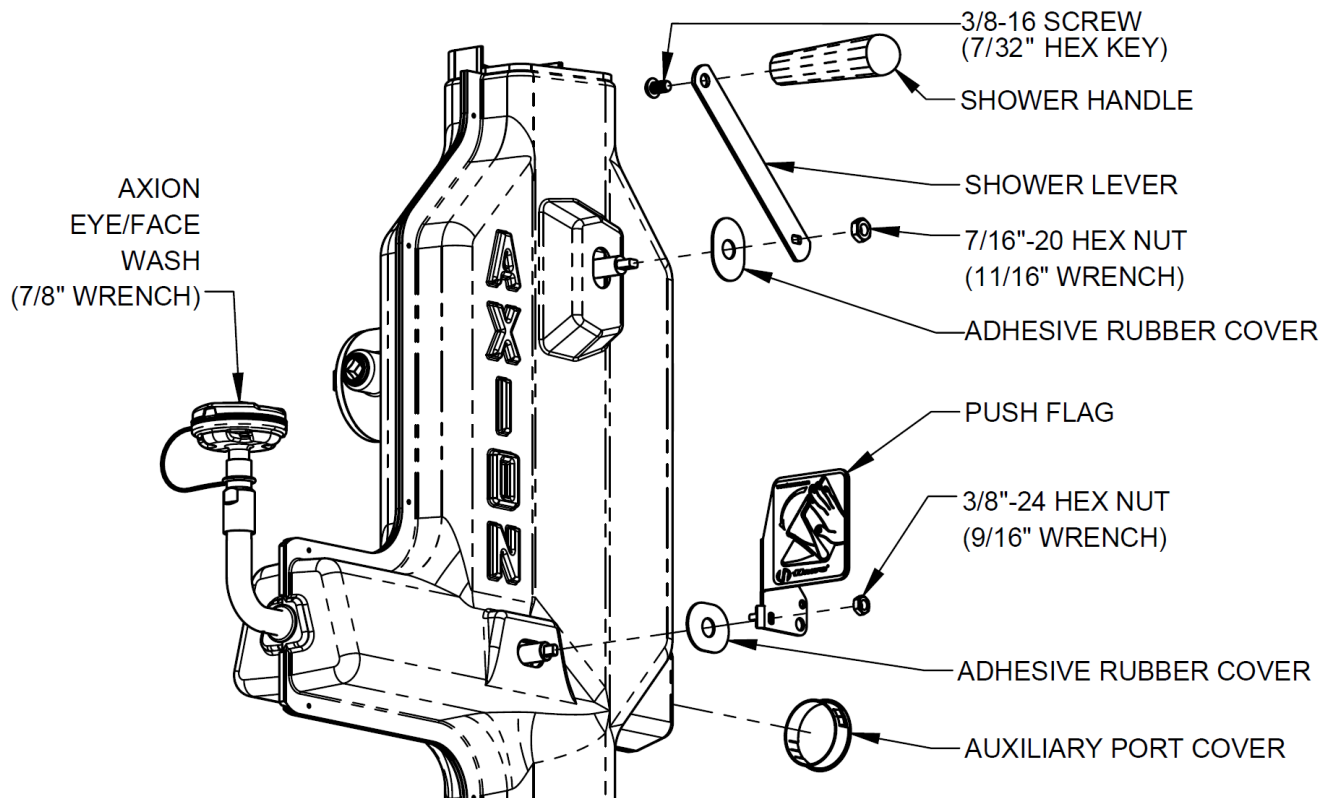

- b) Make sure the local jacket surfaces are clean, then install the 2 adhesive rubber covers over the valve stem openings.
- c) Install the Axion eye/face wash assembly as shown, so eyewash streams can wash both a user's eyes while standing in front of it. If needed, use pipe sealant on the threads.
- d) Assemble the push flag and the shower handle assembly as shown.
- e) Press the black hole plug into the auxiliary port, if unused.

### STEP 8: Electrical & Heat Trace

- a) Connect the electrical power supply conduit to the shower's junction box using a suitable conduit fitting into 3/4" NPT inlet.
- b) If needed, install the optional 8317IDLTE<sub>x</sub>P indicator light, per its O&M.
- c) Wire the electrical supply within the junction box and turn on power supply.

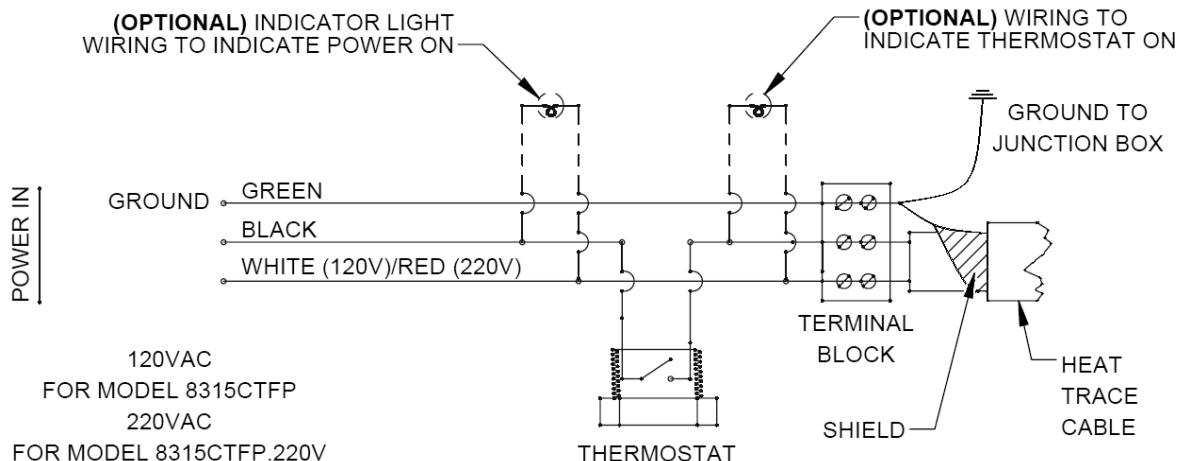

### STEP 9: Miscellaneous

- a) Use the 4 thread-forming screws to bolt the shower sign to the upper vertical jacketing, where the front flanges have been cut away.
- b) Use the small zip tie to hang the test tag at a convenient location – for instance, off of the eye/face wash push flag.
- c) If desired, install the optional shower bell on the shower nozzle by sliding it up onto the nozzle, then sliding the retaining ring up and into its groove on the shower nozzle.
- d) If needed, install an optional SP220 foot treadle, per its installation drawing.

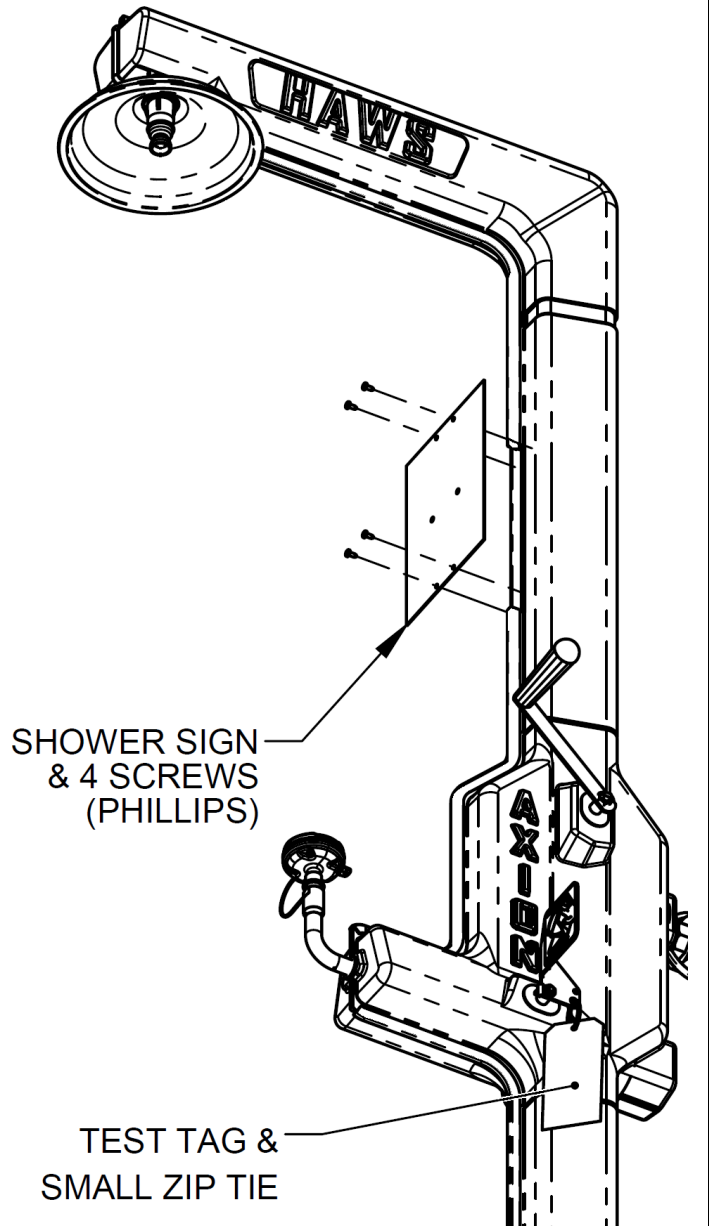



## OPERATING INSTRUCTIONS

The shower feature of the 8315CTFP and 8315CTFP.220V is activated by pulling down on a black handle approximately halfway up the unit. The eye/face wash feature is activated by means of a traditional push flag.

The basic models may be upgraded with a variety of add-on accessory models (bleed valves, indicator lights, foot treadles, etc.), to suit the needs of each individual installation. Please visit [www.hawesco.com](http://www.hawesco.com) for complete details.

These showers are designed such that the plumbing downstream of the eye/face wash and shower valves drains automatically after use. This is accomplished through a small weep hole in the eye/face wash plumbing, and a drainage port in the shower ball valve, respectively. Drain tubing conducts the shower piping water out the base of the unit, near the floor flange. **Make sure water does not continue to run after use (i.e. make sure that the valves are fully closed and that water does not continue to seep slowly out the drain).**

Power to the 8315CTFP and 8315CTFP.220V may be left on year-round. The non-adjustable thermostat will shut off heat cable when air temperature rises to 47° - 57°F (8.3° - 13.9°C). Heat cycle will repeat when air temperature drops to between 37° - 47°F (2.8° - 8.3°C). Periodic check of water temperature from shower or eye/face wash will confirm normal operating temperatures between 45° - 95°F (7.2° - 35.0°C).

This unit is heated by low-power heat trace cable, suitable for freeze protection but not suitable for providing a warm shower from a cold-water supply. Moments after activating the shower, the water temperature will drop to supply temperature.

ANSI recommends a comfortable shower temperature range of 60°F (15°C) to 100°F (38°C). For the protection of the user, Haws strongly recommends that some system be installed to provide tempered (warm) water to this shower and eye/face wash. Heat trace cable used on this shower heats slowly and may take 90 minutes or longer to complete a full heat cycle.

No drain connection at any of the optional bleed valves is normally required. Any such valves will remain closed except in the event of a power outage in cold weather (the optional freeze valve would open), high ambient temperatures (the optional scald protection valve would open) or a product malfunction (see associated Troubleshooting sections).

**NOTE: IF GROUNDWATER IS BELOW 38°F (3.3°C) SIMPLY TESTING THE SHOWER MIGHT CAUSE THE OPTIONAL FREEZE VALVE TO OPEN. ONCE THE VALVE IS OPENED, COLD GROUNDWATER WILL KEEP IT OPEN. SEE THE TROUBLESHOOTING GUIDE FOR THE PROCEDURE TO CLOSE A BLEED VALVE IN SUCH A CONDITION.**

Periodic function tests of the shower and eye/face wash should be performed and recorded on the inspection tag attached to the unit, or in a separate maintenance logbook (preferred).

If the shower's piping has difficulty staying above freezing at extreme temperatures due to strong winds or other natural phenomena, consider installing a failsafe, such as an SP158.15 freeze valve or a windbreak enclosure, such as the 9035 3-sided enclosure.

### IMPORTANT SAFETY NOTICE

THE NATIONAL ELECTRICAL CODE REQUIRES GROUND-FAULT EQUIPMENT PROTECTION ON EACH HEATING CABLE BRANCH CIRCUIT. TO REDUCE THE RISK OF FIRE CAUSED BY DAMAGE OR IMPROPER INSTALLATION, CIRCUIT BREAKERS SUCH AS SQUARE D QO-EPD AND QOB-EPD OR EQUIVALENT, WITH A 30mA TRIP LEVEL, SHOULD BE USED. PLEASE SUBSTITUTE THESE BREAKERS WHEREVER REFERENCE IS MADE TO CONVENTIONAL BREAKERS IN THIS DOCUMENT. ALTERNATIVE DESIGNS PROVIDING COMPARABLE LEVELS OF GROUND-FAULT PROTECTION MAY ALSO BE ACCEPTABLE.

<b><u>TROUBLESHOOTING</u></b>	
<b>PROBLEM</b>	<b>REPAIR CHECKLIST</b>
1. Shower ball valve is stuck.	1. Water is frozen against or within the ball valve. Check for electrical power. Check for clogged shower drain plumbing. Check thermostat as described in item 6.
2. Eye/face wash valve is stuck.	2. Water is frozen against or within the ball valve. Check for electrical power. Check for a fouled drainage weep hole. Check thermostat as described in item 6.
3. Shower or eye/face wash does not dispense.	3. - Verify available water supply. Check for blockage in lines. - Water is frozen within piping downstream of valve. Check for ice here. Check for electrical power. Check for clogged or fouled drainage. Check thermostat as described in item 6.
4. Shower does not drain.	4. Check for clogged shower drain plumbing. If ice is present here, make sure tubing is not kinked or pinched.
5. Eye/face wash does not drain.	5. Check for a fouled drainage weep hole.
6. Shower and eye/face wash water temperature below 40°F or above 100°F.	6. Shut off electrical power. All electrical connections are made inside external junction box. Thermostat is mounted in top port of junction box. Disconnect thermostat leads from terminal block and wire nut in junction box. Check thermostat continuity: open circuit above 57°F (14°C), closed below 37°F (3°C). Thermostat is not adjustable and should be replaced if either of the continuity checks are incorrect. If unit is subject to freezing temperatures, temporarily disconnect thermostat and reconnect wiring to bypass thermostat and protect shower from freezing until replacement thermostat can be installed. Self-regulating heat trace cable will not overheat shower while air temperature is below approximately 40°F (4°C).
7. Insufficient flow at shower AND eye/face wash.	7. Verify minimum 30 PSI (2 ATM), 28 gallon per minute (106 liters per minute) available supply. Check for blockage in lines.
8. Insufficient flow at eye/face wash ONLY.	8. - Probable clogging of flow control due to inadequate line flushing. Turn water supply off. Unscrew eye/face wash heads and adapter to access and clean flow control. - Check for ice buildup in eye/face wash plumbing downstream of activation valve.
9. Insufficient water flow at the showerhead ONLY.	9. - Probable clogging of flow control inside showerhead. Unscrew showerhead and clean rubber flow control. - Check for ice buildup in shower plumbing above activation valve.
10. Eye/face wash valve stem leaks.	10. Remove shower handle and eye/face wash push flag. Pull seal trim off of this area of jacketing and pull the right-side jacket off. Peel back or remove insulation to gain access to valve. Remove "U" bracket from valve stem and tighten valve stem hex packing nut to stop leak. Reassemble bracket, insulation, shower housing and valve arm.
11. Shower valve stem leaks.	11. Stem seal is a double o-ring seal and cannot be adjusted; replace valve. Disassemble as in item 10. Remove shower jacketing and piping to access shower. Any zip ties removed must be replaced exactly after the valve is replaced. Reverse above steps to reassemble.
12. Shower and eye/face wash valve leaks. (Does not shut off completely).	12. Disconnect power to unit. Disassemble as in item 10. Check valve stop tabs for damage. Repair or replace valve assembly. Heat trace is looped around valves and should be pulled away from valve. Any zip ties removed must be replaced exactly after the valve is replaced. Remove valve (removing shower valve will require the removal of shower jacketing and piping). Reverse above steps to reassemble.

THIS DOCUMENT IS TRUE AND CORRECT AT TIME OF PUBLICATION. CONTINUED PRODUCT IMPROVEMENTS MAKE SPECIFICATIONS AND MEASUREMENTS SUBJECT TO CHANGE WITHOUT NOTICE.

ITEM	DESCRIPTION	PART NO.
1	TEST TAG	SP170
2	EYE/FACE WASH ASSY (COVER INCLUDED)	SP65CTFP
3	EYE/FACE WASH COVER	9091
4	THERMOSTAT	SP156
5	SHOWER/EYEWASH SIGN	0510001012
6	SHOWER HEAD	SP829

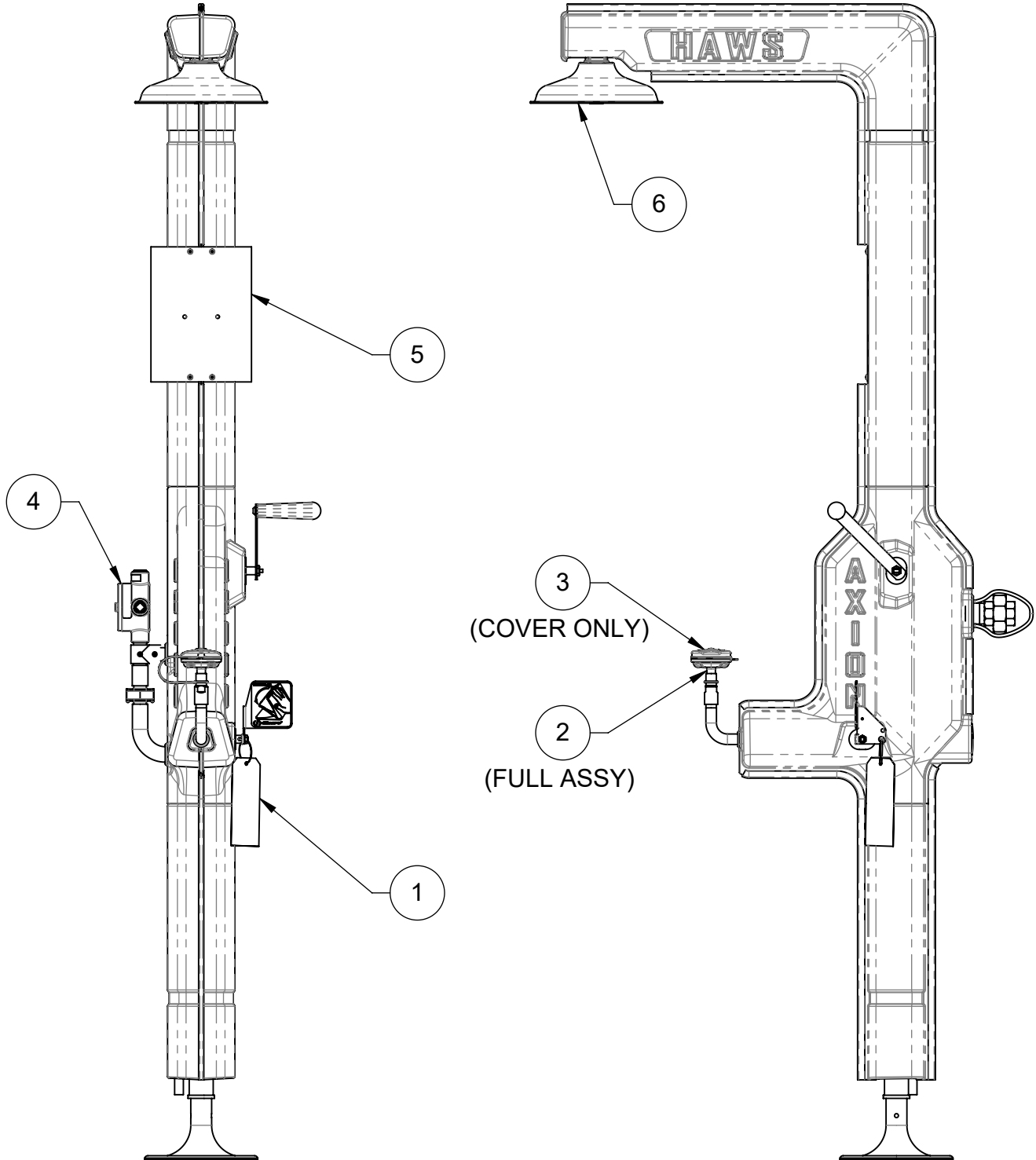

			1455 KLEPPE LANE SPARKS, NEVADA 89431 (775) 359-4712 FAX (775) 359-7424 E-MAIL: HAWS@HAWS.CO.COM WEBSITE: WWW.HAWS.CO.COM	
			ECN: 5566 REV. ECN: 5577 BY: JL DRAWN: JL DATE: 07/23/20 CHKD: DP APPROVED: FV DATE: 11/11/20	MODEL(S) 8315CTFP & 8315CTFP 220V - CABLE-TRACE COMBINATION SHOWER
WHEN ORDERING PARTS, PLEASE SPECIFY PART NUMBER			SCALE: 1:12   DRAWING TYPE: PARTS BREAKDOWN   SIZE: A   SHEET 1 OF 1	

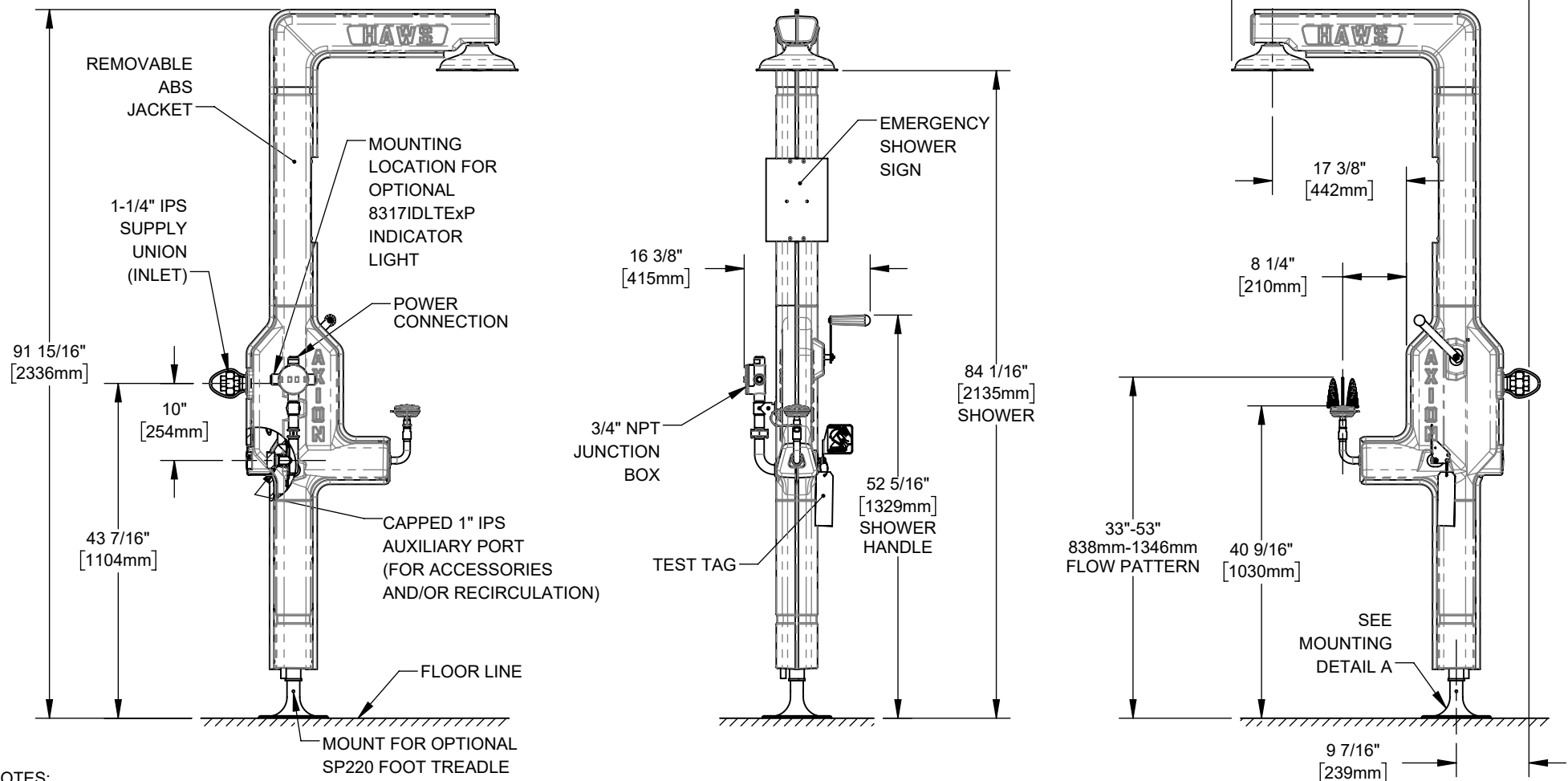

NOTES:

1. WHEN INSTALLING THIS UNIT, LOCAL, STATE, OR FEDERAL CODES SHOULD BE ADHERED TO FOR INSTALLATION DIMENSIONS (LOCATIONS) AND FOR WASTE AND SUPPLY DIMENSIONS OTHER THAN SHOWN.
2. TO COMPLY WITH ANSI Z358.1-2014 FOR EMERGENCY EYEWASH AND SHOWER EQUIPMENT:
  - UNIT SHALL BE INSTALLED IN ACCORDANCE WITH MANUFACTURER'S INSTRUCTIONS AND ACCEPTABLE PLUMBING PRACTICES.
  - EYEWASH STREAMS SHALL BE POSITIONED SUCH THAT STREAMS ARE 15.3 CM (6 IN.) MINIMUM FROM THE WALL OR NEAREST OBSTRUCTION AND, WHEN FLOWING AT 30-30.5 PSI, MEET ANSI GAUGE REQUIREMENTS BETWEEN 83.8 & 134.6 CM (33-53 IN) ABOVE FLOOR.
  - SHOWER SHALL BE POSITIONED SUCH THAT SHOWERHEAD IS BETWEEN 208.3 & 243.8 CM (82-96 IN.) FROM FLOOR.
  - SHOWER SPRAY PATTERN SHALL HAVE A MINIMUM DIAMETER OF 50.8 CM (20 IN.) AT 152.4 CM (60 IN.) ABOVE SURFACE ON WHICH USER STANDS, AND CENTER OF SPRAY PATTERN SHALL BE LOCATED AT LEAST 40.6 CM (16 IN.) FROM ANY OBSTRUCTION.
3. CERTAIN PRODUCT DIMENSIONS MAY VARY BY  $\pm 1/2"$  [133mm] OR MORE.
4. **WARNING:** EYEWASH PLUMBING MUST BE INSTALLED LEVEL SO ALL WATER DOWNSTREAM OF THE BALL VALVE CAN DRAIN AFTER USE. FAILURE TO ENSURE DRAINAGE CAN ALLOW WATER TO POOL AND FREEZE, POTENTIALLY RESTRICTING EYEWASH FLOW OR NOT ALLOWING THE EYEWASH VALVE TO ACTUATE.

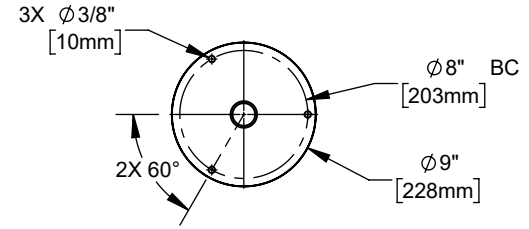

MOUNTING DETAIL A

		1455 KLEPPE LANE SPARKS, NEVADA 89431 (775) 359-4712 FAX (775) 359-7424 E-MAIL: HAWS@HAWSO.COM WEBSITE: WWW.HAWSO.COM	
		ECN: 5566 REV. EGN: 5577 DRAWN: JL APPROVED: FV	BY: JL DATE: 07/23/20 CHKD: DP DATE: 11/11/20
SCALE: 1:20		DRAWING TYPE: INSTALLATION	
SIZE: A		SHEET 1 OF 2	

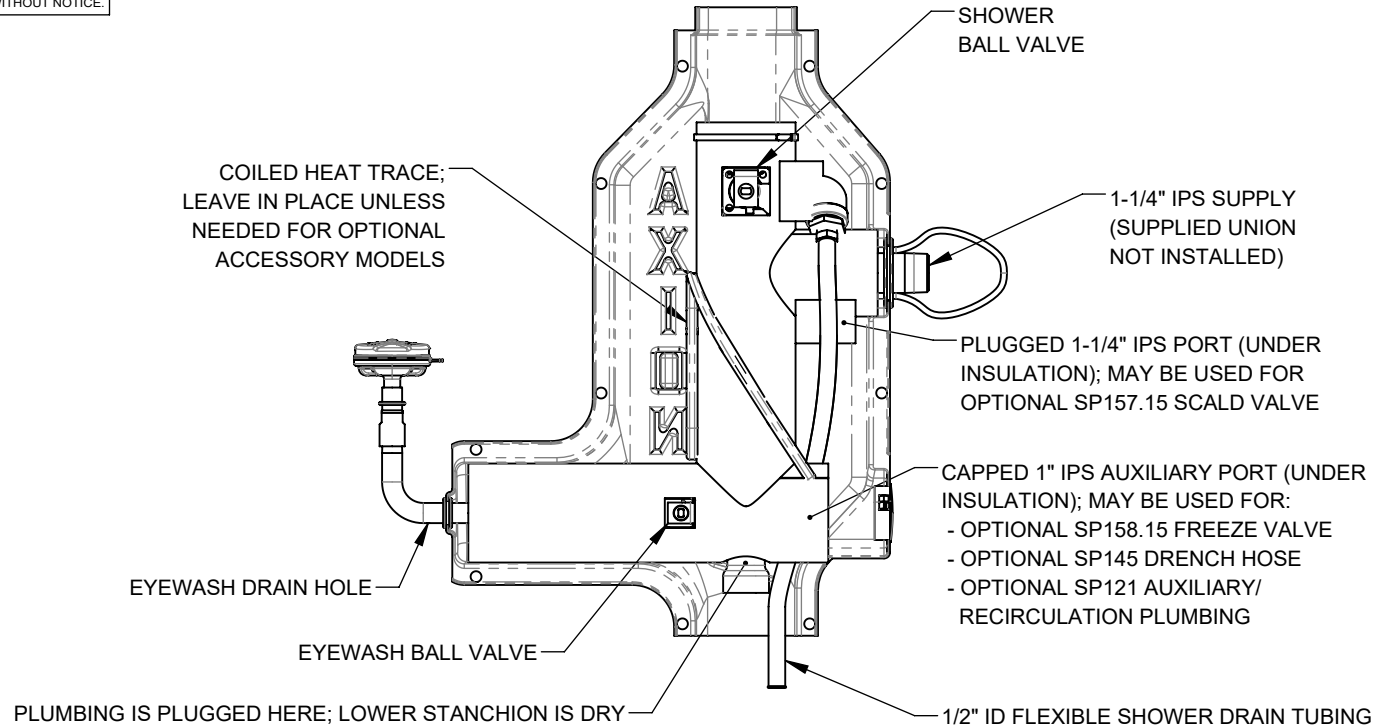

**FACTORY-ASSEMBLED SECTION**  
 (ZIP TIES HIDDEN FOR CLARITY)

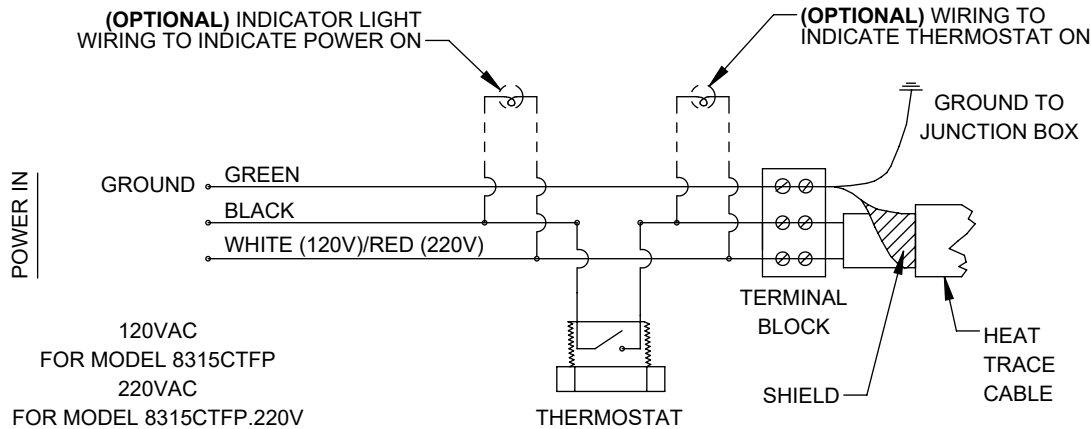

**ELECTRICAL SCHEMATIC**

		1455 KLEPPE LANE SPARKS, NEVADA 89431 (775) 359-4712 FAX (775) 359-7424 E-MAIL: HAWS@HAWS.CO.COM WEBSITE: WWW.HAWS.CO.COM	
		ECN: 5566 REV. ECN: 5577 DRAWN: JL APPROVED: FV	BY: JL CHK'D: DP DATE: 11/11/20
SCALE: N/A		DRAWING TYPE: INSTALLATION	
SIZE: A		SHEET 2 OF 2	