

PRODUCT SPECIFICATIONS

Elkay's self-contained, Touchless handwashing station. Includes touchless electronic faucet, touchless soap and touchless towel dispensers. On-demand water heater, 5 gallon fresh water tank and 6 gallon waste water tank conveniently contained within the mobile cabinet.

Faucet*:	Elkay Commercial Electronic Faucet Model LKB737C, Sensor Activated with auto shut off
Flow Rate:	0.5 GPM
Cabinet Dimensions:	24" x 24" x 62"
Hand Sink:	Stainless Steel 10" X 12" X 6" deep
Water Heater Electrical Rating:	120 VAC 1524 Watts 20A Dedicated Outlet
On Demand Hot Water:	65 to 145 Degrees F
Mixing Valve:	Manual mixing valve
Fresh Water Capacity:	5 Gallon Removable Plastic Tank
Wastewater Capacity:	6 Gallon Removable Plastic Tank
Soap Dispenser*:	Sensor activated, touchless operation, Battery operated. Accepts 1200mL bag refill cartridges
Towel Dispenser*:	Sensor activated, touchless operation, battery operated
Steel Type:	301 Stainless Steel Construction
Features:	Two locking and two non-locking 5 inch casters, handles for moving cabinet and hinged door with locking latch for internal access



Special Note: * To order towel and soap refills, register with Staples at <https://go.staples.com/ElkayRefills.html>.

Patent Pending

- **Sanitary:** All touchless. No need to make contact to activate soap, faucet or towels. Stainless steel cabinet is hygienic, easy to clean and sanitize.
- **Portable:** Can be positioned anywhere hand washing is needed.
- **Durable:** All welded stainless steel construction.
- **Certifications:** Conforms to NSF construction and designed to meet state and local hand washing codes.

AMERICAN PRIDE. A LIFETIME TRADITION.

Like your family, the Elkay family has values and traditions that endure. For almost a century, Elkay has been a family-owned and operated company, providing thousands of jobs that support our families and communities.



[Clean and Care Manual \(PDF\)](#)
[Installation Instructions \(PDF\)](#)
[Warranty \(PDF\)](#)



Internal Cabinet View

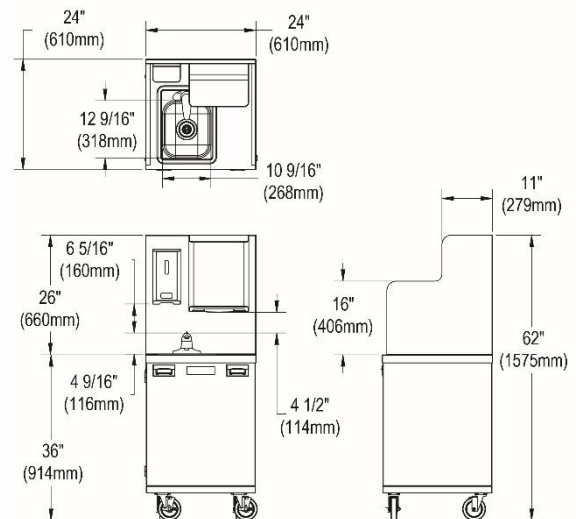

PART: _____ QTY: _____
 PROJECT: _____
 CONTACT: _____
 DATE: _____
 NOTES: _____
 APPROVAL: _____

In keeping with our policy of continuing product improvement, Elkay reserves the right to change product specifications without notice. Please visit elkay.com for the most current version of Elkay product specification sheets. This specification an Elkay product with design, quality, and functional benefits to the user. When making a comparison of other producers' offerings, be certain these features are not overlooked.