

P1 CONFIG.

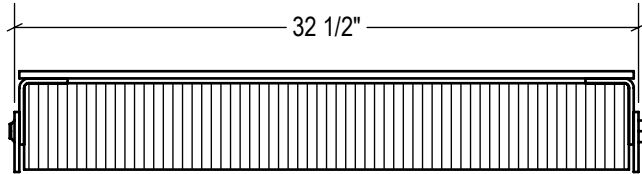

P2 CONFIG.

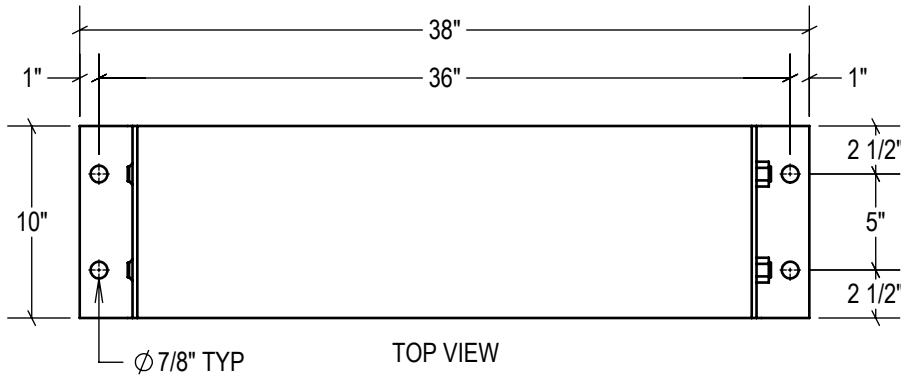

TOP VIEW

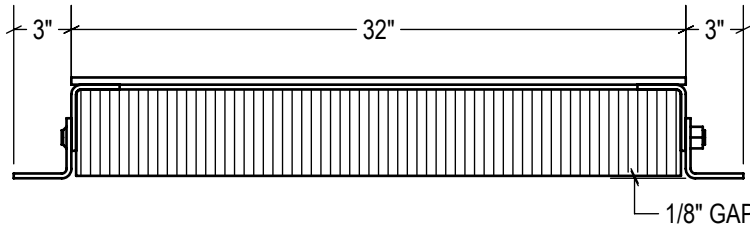

FRONT VIEW

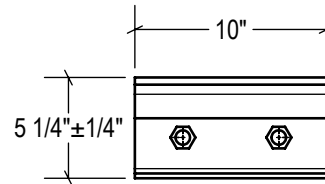

SIDE VIEW

STANDARD
model #: TB410-36SF
part #: 22-6009
Bolted (2) Sides

P1 CONFIG.
model #: TB410-36SF/P1
part #: 22-6010
Welded (1) Side

P2 CONFIG.
model #: TB410-36SF/P2
part #: 22-6011
Welded (2) Sides

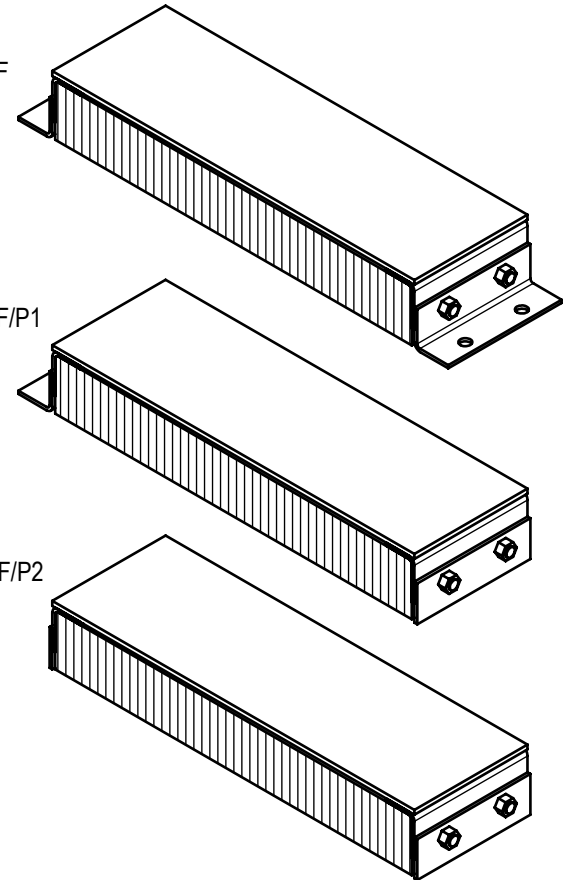

ESTIMATED GROSS SHIPPING WEIGHT = 115 LBS

SPECIFICATIONS:

FURNISH AND INSTALL STEEL-FACED LAMINATED RUBBER DOCK BUMPERS AS MANUFACTURED BY IDEAL WAREHOUSE INNOVATIONS, INC. LAMINATED PADS SHALL BE MADE FROM RECYCLED CONVEYOR BELTING AND TIRE RUBBER CUT TO 4.125" x 10" PUNCHED AND ASSEMBLED THROUGH 3/4" RODS BETWEEN 3" x 3" x 1/4" FORMED STEEL UNDER 1,500LBS OF PRESSURE. FINISH OF EXPOSED METAL SHALL BE PAINTED WITH WATER-BASED AND LEAD-FREE PAINT OR HOT-DIPPED GALVANIZED (OPTIONAL).

ALL DIMENSIONS ARE ± 1/8" UNLESS SPECIFIED OTHERWISE

DRAWN BY:

T.CHUNG

CHECKED BY:

DATE:

12/12/2018

DATE:

THE INFORMATION CONTAINED IN THIS DRAWING IS THE SOLE PROPERTY OF IDEAL WAREHOUSE INNOVATIONS INC. ANY REPRODUCTION IN PART OR AS A WHOLE IS PROHIBITED.



3rd Angle

SIZE:

A



IDEAL WAREHOUSE INNOVATIONS INC

DESCRIPTION:
STEEL-FACED LAMINATED BUMPER TB410-36SF

SCALE: 1:10	SHEETS: 1 of 1	DRAWING NUMBER: MKT_TB410-36SF	REV: 1
-----------------------	--------------------------	--	------------------