

# OPERATOR'S MANUAL



## POWERED PALLET TRUCK

U.S. Patent Nos. D739,112; D770,719; D770,720;  
8,540,213; 8,833,736; 9,079,754; D692,202;  
D692,203; D692,204 and D767,236

# **WARNING**

**Do not operate this truck unless you have been authorized and trained to do so, and have read all warnings and instructions in Operator's Manual and on this truck.**

Do not operate this truck until you have checked its condition. Give special attention to tires, horn, battery, controller, lift system, brakes, steering mechanism, guards and safety devices.

Operate truck only from designated operating position. Do not carry passengers. Keep feet clear of truck and wear foot protection.

Observe applicable traffic regulations. Yield right of way to pedestrians. Slow down and sound horn at cross aisles and wherever vision is obstructed.

Start, stop, travel, steer and brake smoothly. Slow down for turns and on uneven or slippery surfaces that could cause truck to slide or overturn. Use special care when traveling without load as the risk of overturn may be greater.

**Always look in direction of travel. Keep a clear view, and when load interferes with visibility, travel with load trailing.**

**Use special care when operating on ramps - travel slowly, and do not angle or turn. Travel with lifting mechanism downhill.**

Do not overload truck. Check nameplate for capacity and load center information.

**Do not handle loads which are higher than the load backrest or load backrest extension unless load is secured so that no part of it could fall backward. Before lifting, be sure load is centered, forks are completely under load, and load is as far back as possible against load backrest.**

**When leaving truck, neutralize travel control, fully lower lifting mechanism and set brake. When leaving truck unattended, also shut off power.**

## PROPOSITION 65



### WARNING

In accordance to

**California Health & Safety Code Sections 25249.5 et. seq.** this warning is to let you know that this product can expose you to chemicals known to the state of California to cause cancer, birth defects and other reproductive harm.

For more information visit: [www.p65warnings.ca.gov](http://www.p65warnings.ca.gov)

# FOREWORD

As a lift truck operator, you are responsible for a machine that is useful, powerful, and can be hazardous if not operated as described. Your Big Lift LLC truck may weigh more than some cars, depending on the model. Observing and practicing the safety warnings in this manual cannot be overemphasized. Just knowing the warnings, however, is no substitute for common sense. Focusing on the task at hand will, in almost all cases, prevent accidents. Think of the truck as your own. In this way you will learn its capabilities and limitations.

This manual is intended to remain with the truck at all times as a handy

reference guide to operation. Detailed maintenance procedures are found in the parts and service manual for the specific truck model, and are to be performed only by a qualified technician. For further information on obtaining a complete parts and service manual, see [page 21](#) of this manual.

The operator who knows his truck will learn to spot problems as they develop. This is accomplished by performing the Daily Checks and reporting any problems to the designated authority.

## TABLE OF CONTENTS

<b>SAFETY SYMBOLS .....</b>	<b>2</b>
<b>GENERAL DESCRIPTION .....</b>	<b>2</b>
<b>NAME PLATE AND WARNING DECAL .....</b>	<b>2</b>
<b>LOAD CAPACITY .....</b>	<b>6</b>
<b>BEFORE OPERATION .....</b>	<b>7</b>
<b>INSTRUMENTS AND CONTROLS .....</b>	<b>9</b>
<b>OPERATION .....</b>	<b>11</b>
<b>Forward and Reverse Travel and Speed Control .....</b>	<b>11</b>
<b>Steering .....</b>	<b>11</b>
<b>Stopping .....</b>	<b>12</b>
<b>Parking .....</b>	<b>12</b>
<b>Battery Charging .....</b>	<b>13</b>
<b>Load Handling .....</b>	<b>13</b>
<b>Moving a Disabled Truck .....</b>	<b>13</b>
<b>NOTICE - OBTAINING A PARTS AND SERVICE MANUAL .....</b>	<b>21</b>

## SAFETY SYMBOLS

**WARNING** and **CAUTION** are both signal words intended to alert the viewer to the existence and relative degree of a hazard. They are both preceded by a safety alert symbol consisting of an exclamation mark enclosed by a triangle.



A **Warning** indicates a hazard which could result in injury or death if proper precautions are not taken.

A **Caution** indicates a reminder of routine safety practices.

A prohibition slash (circle with diagonal slash through it) indicates a procedure or action that should **not** be performed under any circumstances, as both personal injury and/or damage to equipment will result.



## GENERAL DESCRIPTION

Big Lift LLC Pallet trucks lift and transport loads on rigid forks.

Control for steering, braking, forward and reverse travel, horn, lift, lower and speed control are all located on the control handle.

Trucks in this series may vary in load capacity, battery arrangement, and instrumentation, depending on model and options.

## NAME PLATE AND WARNING DECAL

Name plate and warning decal locations may vary between models, but they are always near the steering arm within sight of the operator.

If the name plate or warning decal are lost or damaged they should be replaced immediately. Have your supervisor or the designated authority contact Big Lift LLC Authorized Dealer for replacement.

The name plate shows the model number, serial number, and truck type. Battery type, with voltage and minimum weight, is shown along with information on the load capacity and load center.

The warning decal contains warnings which also appear, with illustrations, in the Operating Precautions section of this manual.

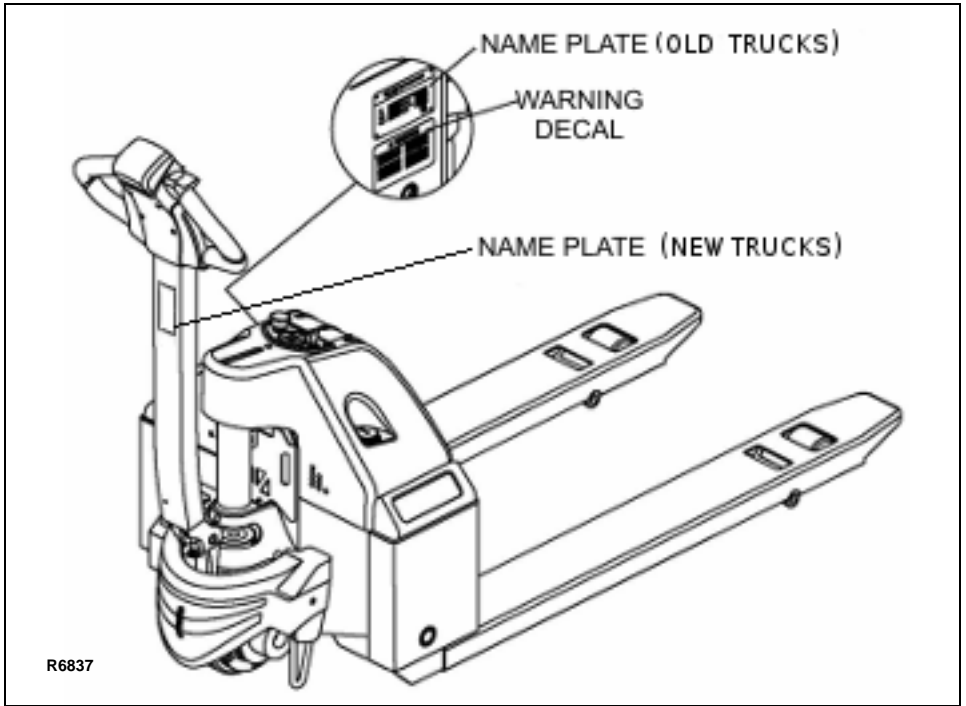

**E30 / EZ30 Name Plate and Warning Decal Locations - Typical**

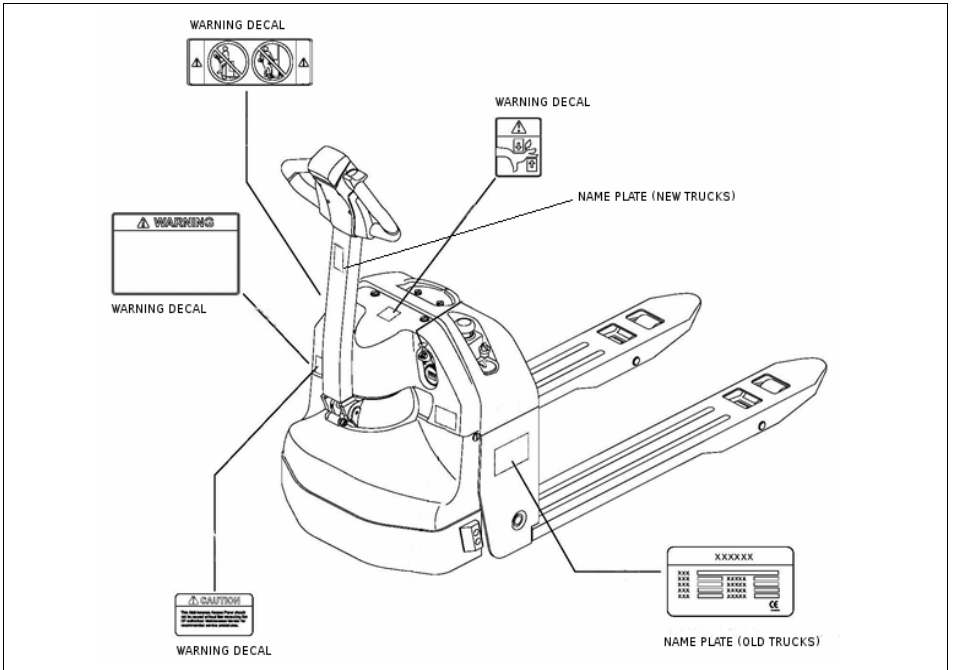

**D40 / EZ40 Name Plate and Warning Decal Locations - Typical**

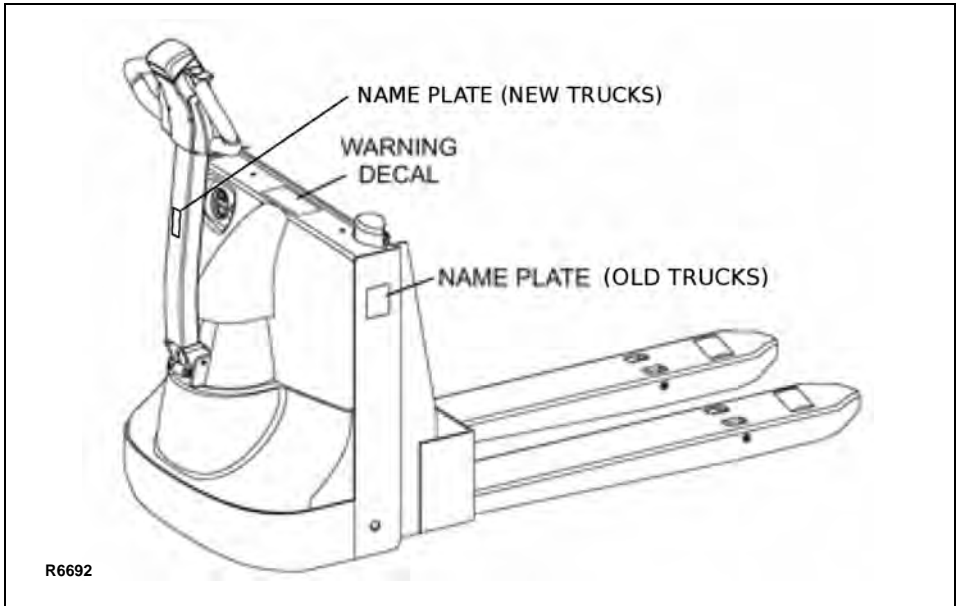

**WPT Name Plate and Warning Decal Locations - Typical**

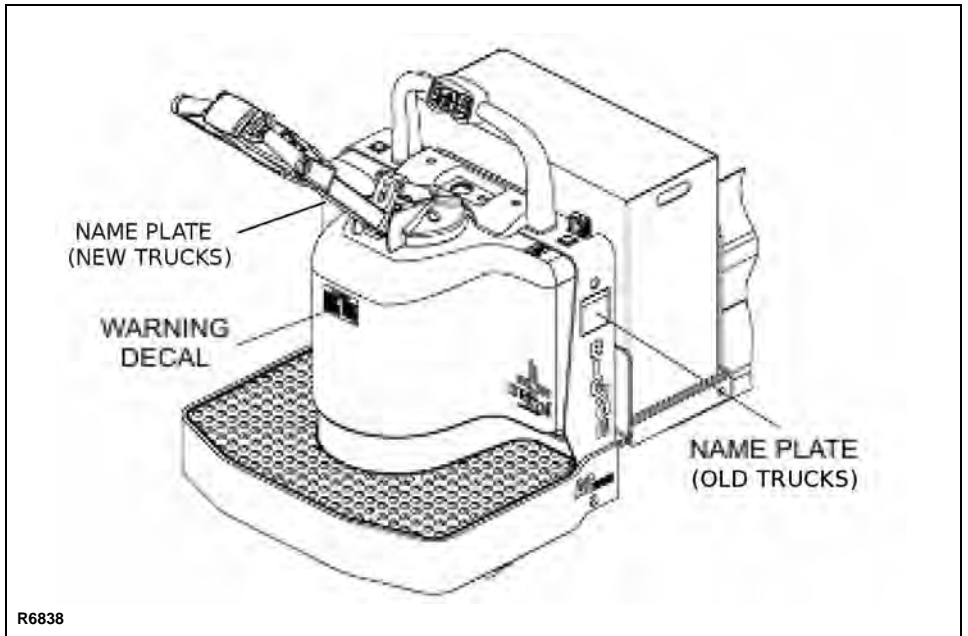

**WRT Name Plate and Warning Decal Locations - Typical**



**WARNING:**

This truck is equipped with a battery. Read and heed the following warning plus any other warnings located near or on the battery. An example is shown here:

<p><b>BATTERY HAZARD</b></p> 	<p><b>⚠ DANGER</b></p> <p><b>EXPLOSIVE/POISON/CAUSTIC</b> <b>NO SPARKS, FLAMES, SMOKING</b> <b>BATTERY ACID</b> can cause blindness and severe burns</p> <p><b>SHIELD EYES, AVOID SKIN CONTACT</b></p> <p><b>IF SPLASHED</b> flush immediately with water, get medical help fast.</p> <p>Do not service battery while on charge. Do not connect or disconnect battery from charger while charger is on.</p> <p>Only qualified and experienced personnel should perform maintenance and repair on batteries. Use caution while servicing or removing battery. (Refer to Battery Safety Sheet).</p>
--	---

## LOAD CAPACITY

Do not overload truck. Check name plate for load weight capacity and load center information.

The load capacity depends on the load center. The load maximum capacity listed on the capacity plate assumes a uniform load whose center is at  $1/2$  the length of the fork and centered between the forks. The maximum load capacity is reduced when

the load center exceeds  $1/2$  the length of the forks or is not centered between the forks. The fork length and wheel-base must be adequate for the skid or bin to be handled.

Note that a truck undergoing speed changes is less stable than a standing truck. If you are not sure that the truck can lift a certain load, consult your supervisor or the designated authority.

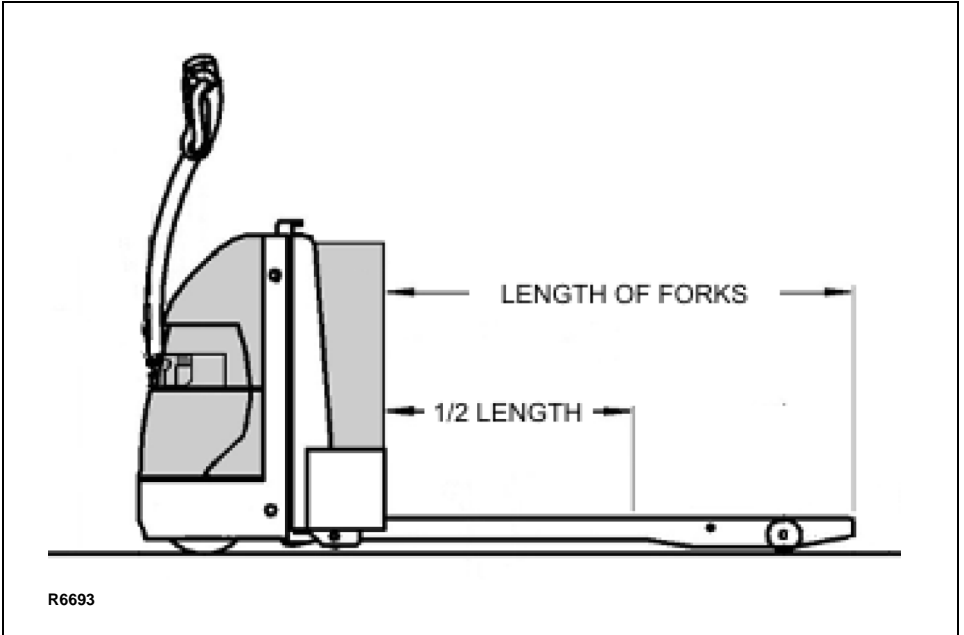

Load Center



# BEFORE OPERATION

The table on [page 8](#) covers important inspection points on trucks which should be checked prior to operation. Depending on use, some trucks may require additional checks.

The illustration below shows a sample format for an Operator Checklist, which can be modified as necessary to fit your operation.



**WARNING:**

Periodic maintenance of this truck by a QUALIFIED SERVICE TECHNICIAN is required.



**WARNING:**

A QUALIFIED SERVICE TECHNICIAN should check the truck

monthly for proper lubrication, proper fluid levels, brake maintenance, motor maintenance and other areas specified in the parts and service manual maintenance section.



**WARNING:**

If the truck is found to be unsafe and in need of repair, or contributes to an unsafe condition, report it immediately to the designated authority. Do not operate it until it has been restored to a safe operating condition. Do not make any unauthorized repairs or adjustments. All service must be performed by a qualified maintenance technician.



Electric Truck  
Daily Operator Check-Off List

---

Date \_\_\_\_\_

Truck No. \_\_\_\_\_

Dept. \_\_\_\_\_

Hour Meter Reading \_\_\_\_\_

Operator \_\_\_\_\_

Model No. \_\_\_\_\_

Shift \_\_\_\_\_

Hour \_\_\_\_\_

Check	OK ( )	✓	Needs Attention
Tires			
Load Wheels			
Horn			
Left Lower Control			
Attachment Operation			
Forward & Reverse Controls			
Steering			
Electrical System			
Hydraulic Leaks, Cylinders, Valves, Hoses, Etc.			

**R6235**

**Sample of Operator Check List**

## Operator Checks

ITEM	PROCEDURE
Transmission and hydraulic systems	Check for signs of fluid leakage.
Forks	Check for cracks and damage.
Guards and load backrest	Check that safety guards are properly secured and not damaged.
Safety signs	Check that warning labels, nameplate, etc., are in good condition and legible.
Horn	Check that horn sounds when operated.
Steering	Check for binding or looseness in steering arm when steering.
Travel controls	Check that speed controls on control handle operate in all speed ranges in forward and reverse and that belly button switch functions.
Wheels	Check drive wheel for cracks or damage. Move truck to check load wheels for freedom of rotation.
Hydraulic controls	Check operation of lift and lower to their maximum positions.
Brakes	Check that brakes actuate when steering arm is raised to upright position, and when lowered to horizontal position.
Deadman/Parking brake	Check that steering arm raises to upright position when released and brake applies.
Battery disconnect	Check that battery can be disconnected and reconnected. Check for connector damage.

## INSTRUMENTS AND CONTROLS

The steering arm and control handle provide controls for steering, forward and reverse speed control, braking, raising and lowering the forks, and

horn. Control handles on all models have a “belly-button” reversing switch which reverses the direction of the truck upon contact with the operator.

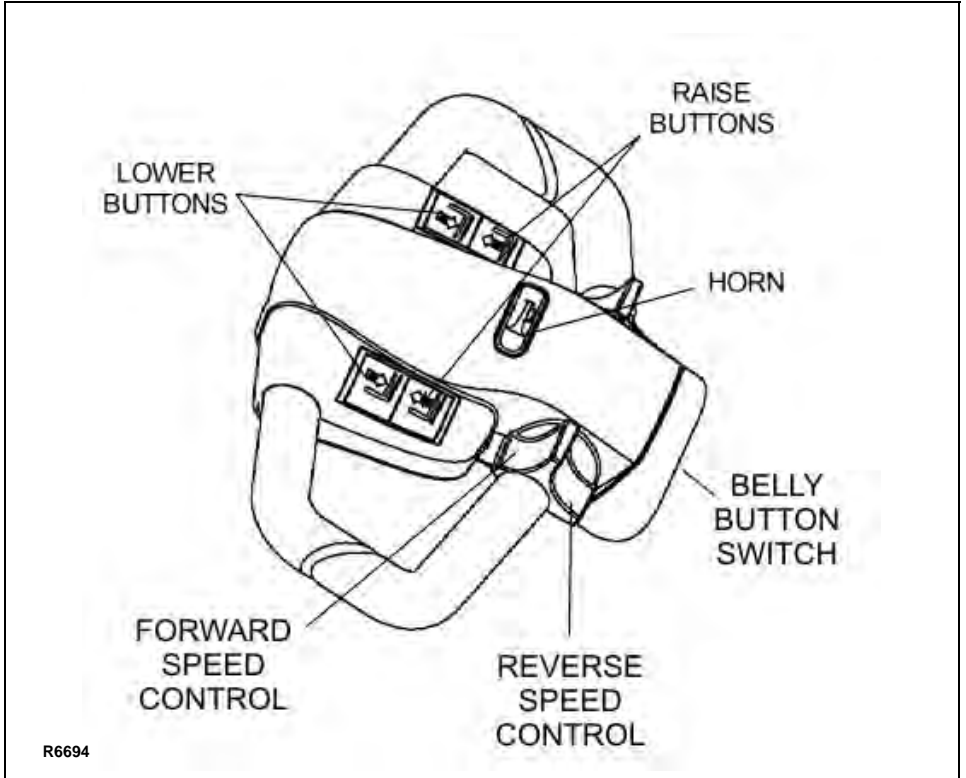

**Control Handle**

Walkie/Rider Pallet Trucks have a grab bar which also contains lift, lower and horn controls. Detailed operating instructions are in the Operation section of this manual.

On the WPT & WRT trucks a battery disconnect is mounted near the steering arm. Pulling the disconnect removes all power from truck circuits in the event of an emergency.

On the E30/EZ30 and D40/EZ40 pushing the red disconnect plunger removes all power from the truck circuits in the event of an emergency.

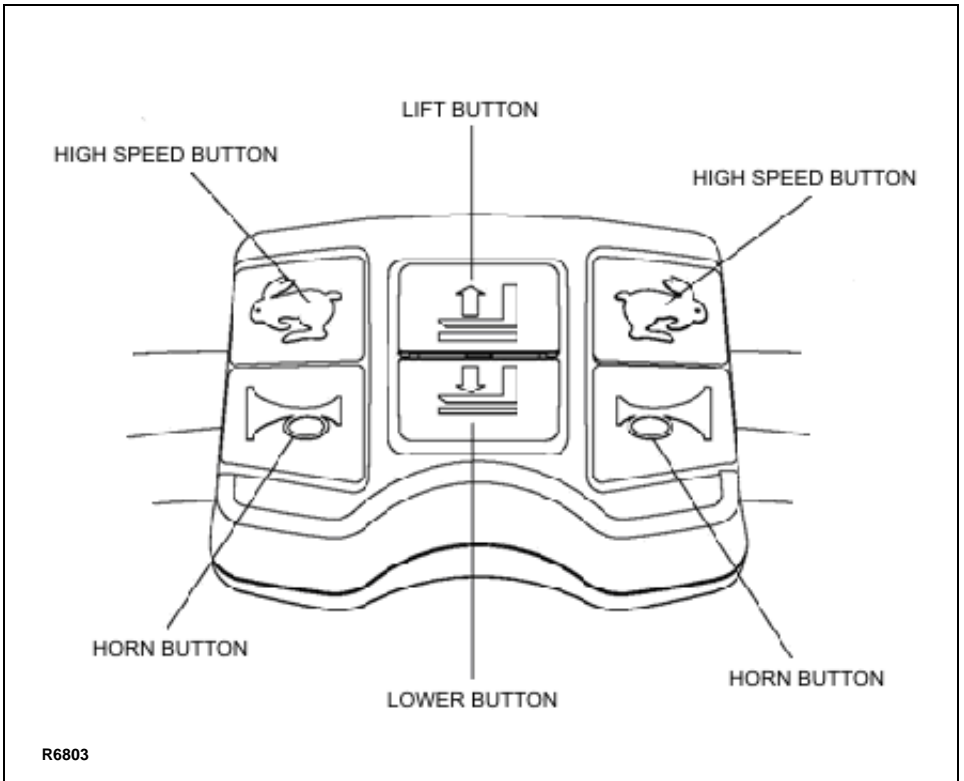

**Grab Bar**

# OPERATION

## Forward and Reverse Travel and Speed Control

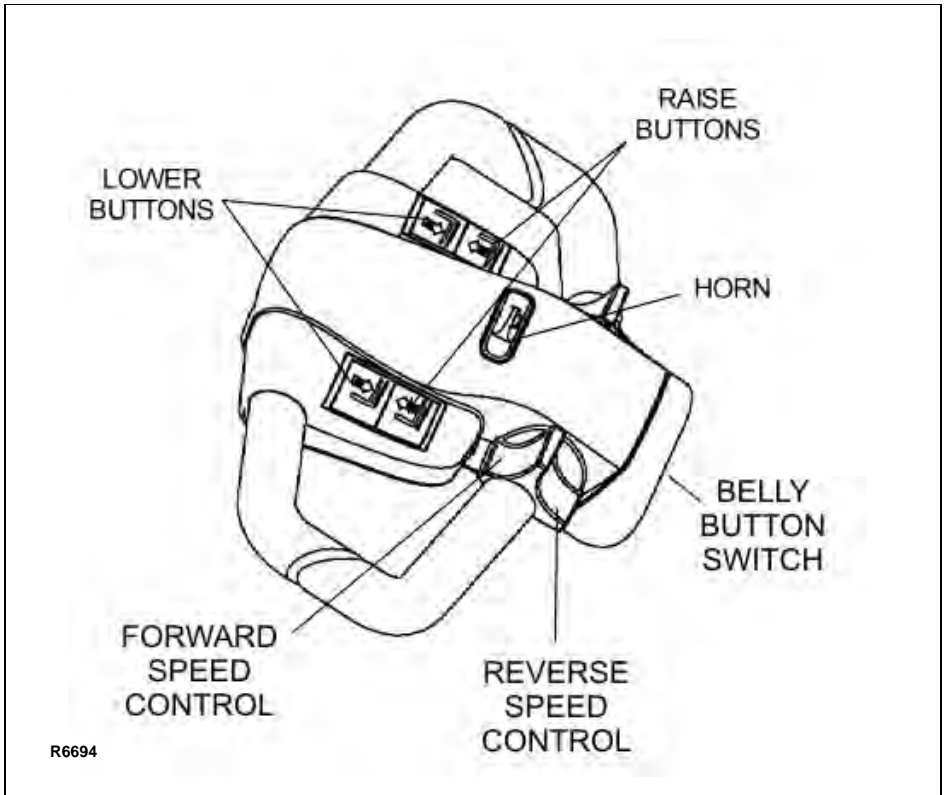

### Control Handle

All directional and speed controls are located on the control handle.

Forward and reverse are controlled by rotating the speed control lever as shown. The lever is spring loaded to return to neutral when released. Further rotation in either direction will progress the truck from slow to maximum travel speed.

To change directions or to stop the truck, rotate the speed control lever in the opposite direction. The truck will

come to a stop and then, unless the controls are returned to the center neutral position, accelerate in the opposite direction.

### Steering

Moving the control handle (which connects to the steering arm) right or left will turn the truck right or left. When maneuvering around corners, make square turns and be sure there is adequate clearance.

## Stopping

Stop the truck as gradually as possible. Unnecessary rapid stopping could be hazardous. Load could become unstable.

To stop the truck's movement (forward or reverse), raise the control handle to the up position or push the control handle all the way down. In both positions, the brake will apply. To release the brake, just move the control handle to the operating position.

**NOTE:** The steering arm gas spring automatically raises the steering arm to the upright position when the steering arm is released.

**CAUTION:** If the control handle does not raise immediately to the vertical position when

released, the truck should be placed "OUT OF SERVICE" until it can be inspected by a qualified service technician.

## Parking

When parking the truck, do not obstruct traffic lanes or aisles.

1. Park the truck in its designated parking area.
2. Raise the steering arm until vertical to apply the parking brake.
3. Fully lower forks.
4. Turn keyswitch to off position. Remove key for added security.
5. On the WPT & WRT pull out battery disconnect or push the red disconnect plunger on the E30/EZ30 and D40/EZ40.

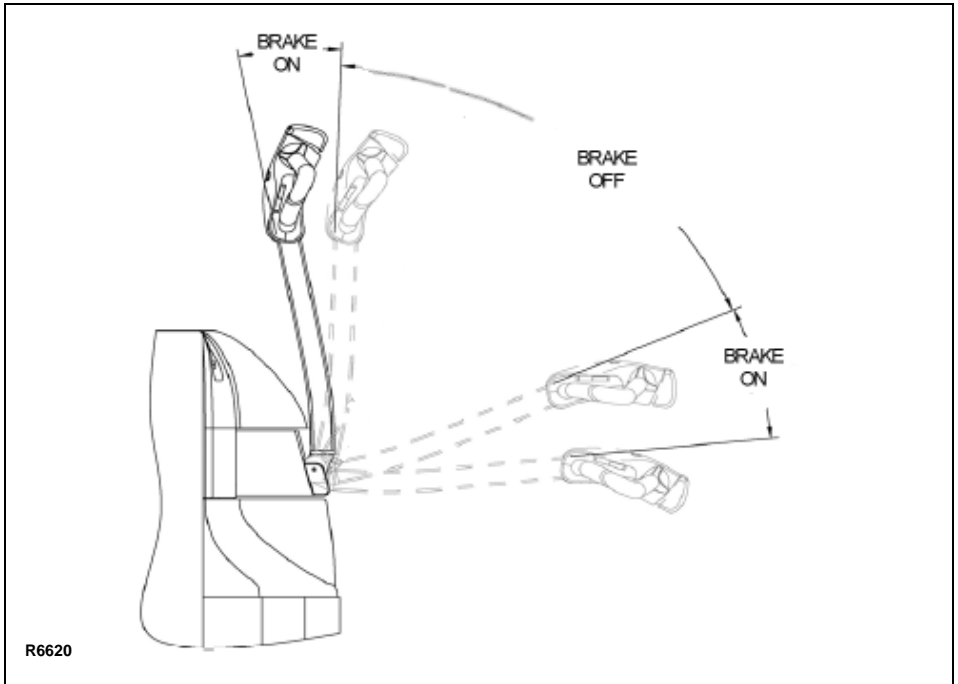

**Steering Arm Braking Positions**

## Battery Charging

Refer to DOC 245 for battery safety and maintenance.

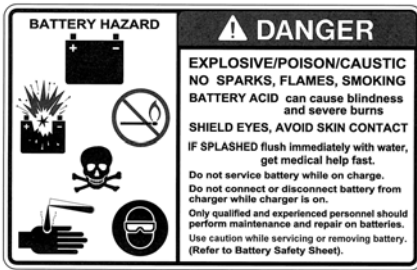

**NOTE:** Battery charging instructions are contained in the service manual.

## Load Handling



### WARNING:

Handle only loads arranged for stability and always use caution. Raise and lower the load smoothly to prevent the load from falling.



### WARNING:

Always be sure the load and load center are within the capacity of the truck. If in doubt check the nameplate.

1. Approach the load slowly.
2. Move the truck slowly into position so that the forks are within pallet or skid, and the load is centered over the forks and as far back as possible.

3. Raise the forks to lift load.
4. Lead the truck by the control handle with the load trailing except when in confined areas. Ramps should be traveled with operator uphill of truck when empty, or operator downhill of truck with load on forks standing off to side of truck.
5. Always look in the direction of travel. Move slowly and check clearances when approaching obstructions.
6. Do not make sudden starts and stops. Operate truck smoothly and gradually.
7. Travel slowly and squarely around corners. Remember that the trailing load wheels do not follow the turn path of the drive wheel. Instead they tend to cut the corner.
8. Line up the truck with the unloading area.
9. Stop the truck and check the load alignment with surrounding objects.
10. Be careful not to damage or move adjacent loads and objects.
11. Lower the forks until the load is resting on its own.
12. Move the truck back until the forks are clear of the pallet.

## Moving a Disabled Truck

Do not attempt to move a disabled truck; notify your supervisor or proper authority.

The following operating instructions appear on the truck warning decal, which is located near the steering arm.

Do not operate this truck unless you have been trained and authorized to do so, and have read and understand all warnings and instructions contained in this operator's manual and on this truck.



R6695

Do not operate this truck until you have checked its condition. Give special attention to wheels, horn, battery, controller, lift systems, brakes, steering mechanism, guards and safety devices. If you have any questions, notify your supervisor or proper authority.

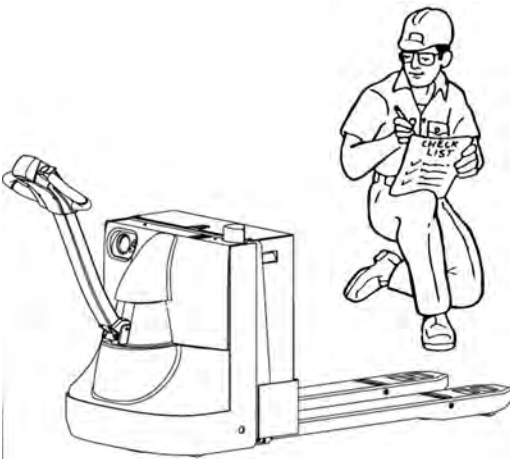

R6696



**Walkie Pallet Trucks:** Operate truck only from walking position.



R6697

**Walkie/Rider Pallet Trucks:** Keep feet within limits of truck.

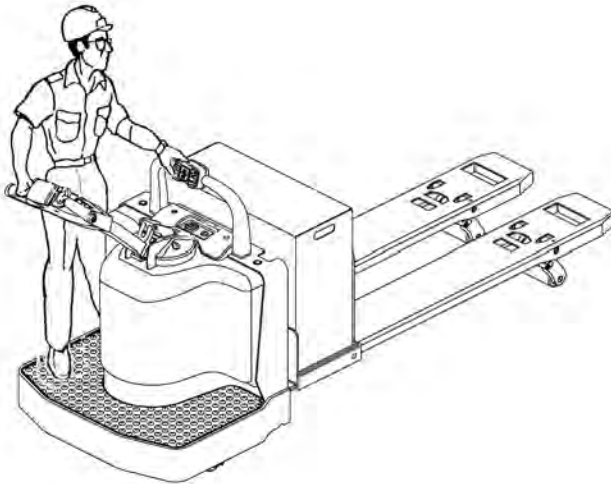

R6839

Wear foot protection and keep feet clear of truck.



R6699

Do not carry passengers.



R6701

Observe applicable traffic regulations. Yield right-of-way to pedestrians. Slow down and sound horn at cross aisles and wherever vision is obstructed.



R6702



Start, stop, travel, steer and brake smoothly. Slow down for turns and on uneven or slippery surfaces that could cause truck to slide or overturn. Use special care when traveling without load as the risk of overturn may be greater.

R6703

Always look in direction of travel. Keep a clear view, and when load interferes with visibility, travel with load or lifting mechanism trailing (except when climbing ramps).

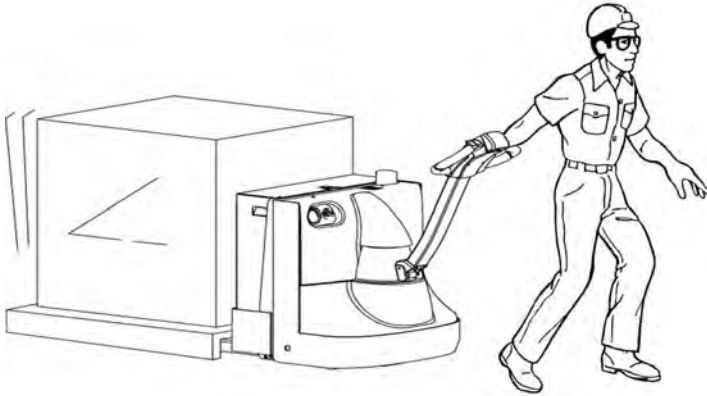

R6704

Use special care when operating on ramps; travel slowly, and do not angle or turn. Travel with lifting mechanism downhill.

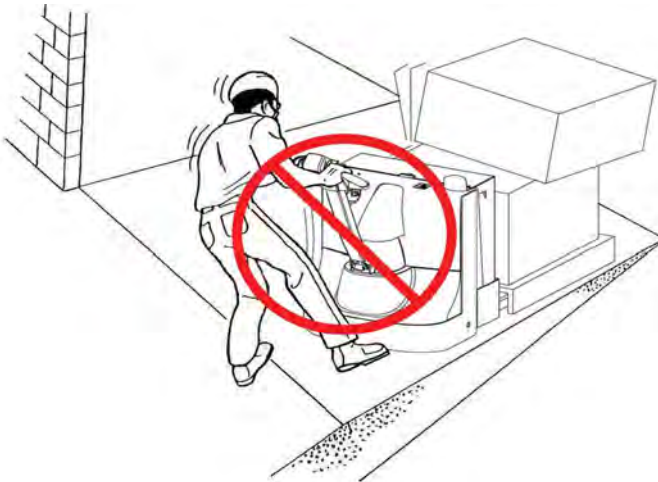

R6705

Do not handle loads which are higher than load backrest or load backrest extension unless load is secured so that no part of it could fall backward.



R6706

Before lifting, be sure load is centered, forks are completely under load, and load is as far back as possible against load backrest.

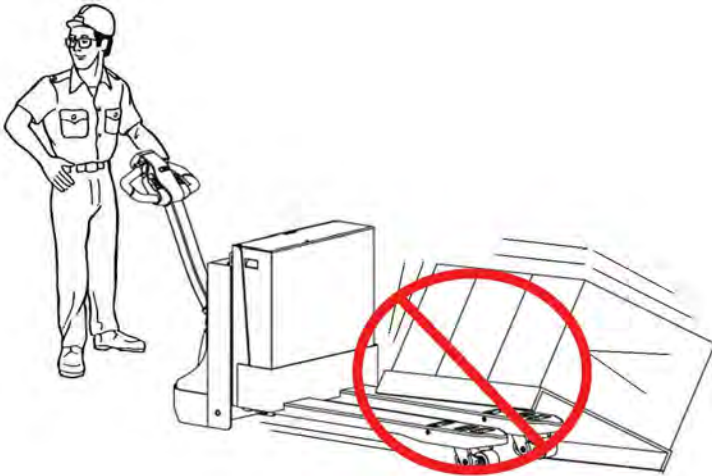

R6705

Keep hands out of lifting mechanism.



R6708

When leaving truck neutralize travel control. Fully lower lifting mechanism and set brake. When leaving truck unattended also shut off power.

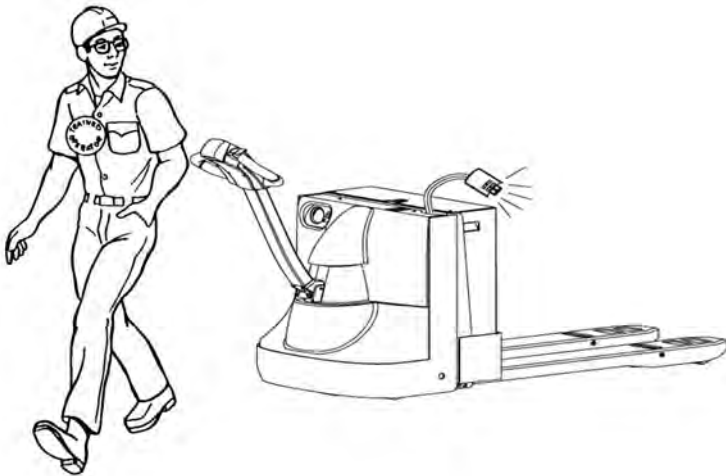

R6709

## **NOTICE - OBTAINING A PARTS AND SERVICE MANUAL**

A complete parts and service manual covering this truck is available from Big Lift LLC. To order, obtain the serial number of your truck and contact your Big Joe Authorized Dealer.



**Big Lift LLC**