

# 1.5 Quart Phlebotomy Sharps Container

Global Industrial Item #: 732122

Oakridge Item #: 0310-150T



## General Description

- Designed for use as a transportable Phlebotomy container
- Flip Door to allow for safe disposal of sharps
- Includes needle unwinder for luer and pen needles
- Puncture resistant
- Permanent lock for final disposal
- Made of High Impact Polypropylene
- Meets all FDA, OSHA, and NOSHA regulations
- Use instructions on part label
- Comparable to: BD 305487
- Fits BD holder 305970

For final lock: insert locking tab into lid slot

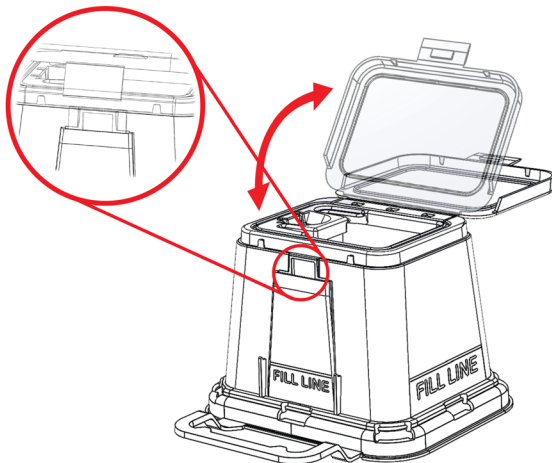

## Packing Details

Part Dimensions:	4.7 x 4.0 x 9.1
Case:	36 each/case
Packaged:	Bulk, Nested
Case Dimensions:	18.25 x 9.25 x 15.50
Case Volume:	1.52 ft <sup>3</sup>
Case Weight:	14 lbs
Cases per Skid:	40
Case GTIN#	10852482006417
Part GTIN#	00865273000410

Case measurements have a margin of error up to +/- .5 and are rounded to up to the nearest hundredth

Manufactured by Oak Ridge Products, LLC  
FDA Manufacturing Facility Registration  
#1419823 & 3006060667

 **GLOBAL**  
**INDUSTRIAL**  
*We can supply that.®*

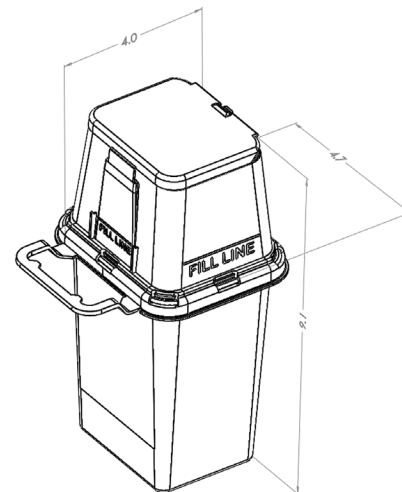

Product dimensions listed are in inches and rounded to the nearest tenths