

8 Gallon Sharps Container

Global Industrial Item #: 732120

Oakridge Item #: 0380-1500

General Description



- Multi-purpose container suitable for OR and dialysis
- Rotating Door provides Temporary closure
- Locks for final Disposal
- Dual openings accommodates sharps of various sizes.
- Includes needle unwinder
- Puncture resistant
- Made of high impact polypropylene
- Reinforced hinge as requested by FDA
- Meets all FDA, OSHA and NOSHA
- Use instructions on part label
- Comparable to Covidien 8980
- Fits Covidien holder: 8984, 8992H

Packing Details

Part Dimensions:	15.3 x 10.9 x 17.3
Case:	10 each/case
Packaged:	Bulk, Nested
Case Dimensions:	25.00 x 17.00 x 27.00
Case Volume:	6.64 ft ³
Case Weight:	27 lbs
Cases per Skid:	18
Case GTIN#	10852482006400
Part GTIN#	00865273000403

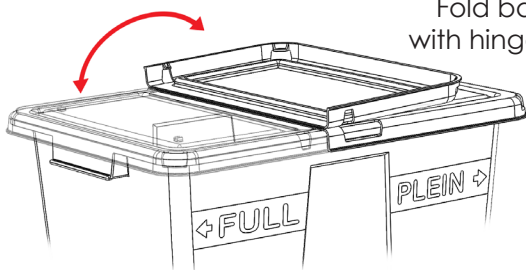
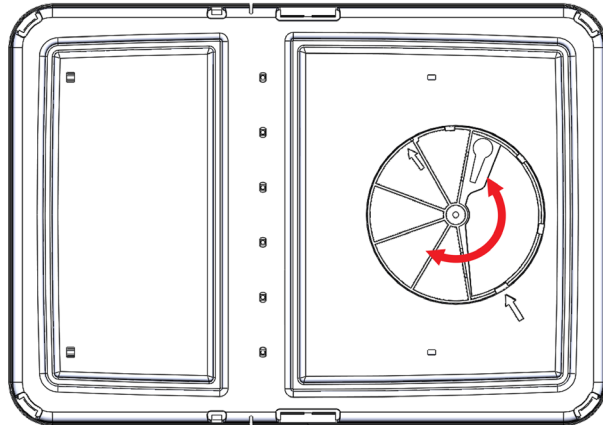

Fold back lid
with hinge guard

