

4

3

2

REVISIONS				
REV.	ZONE	DESCRIPTION	DATE	REVISOR

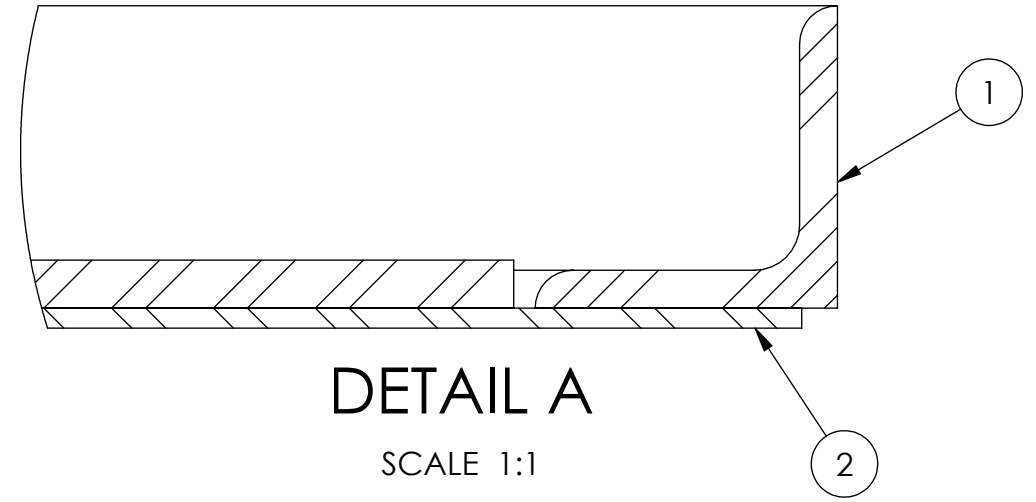
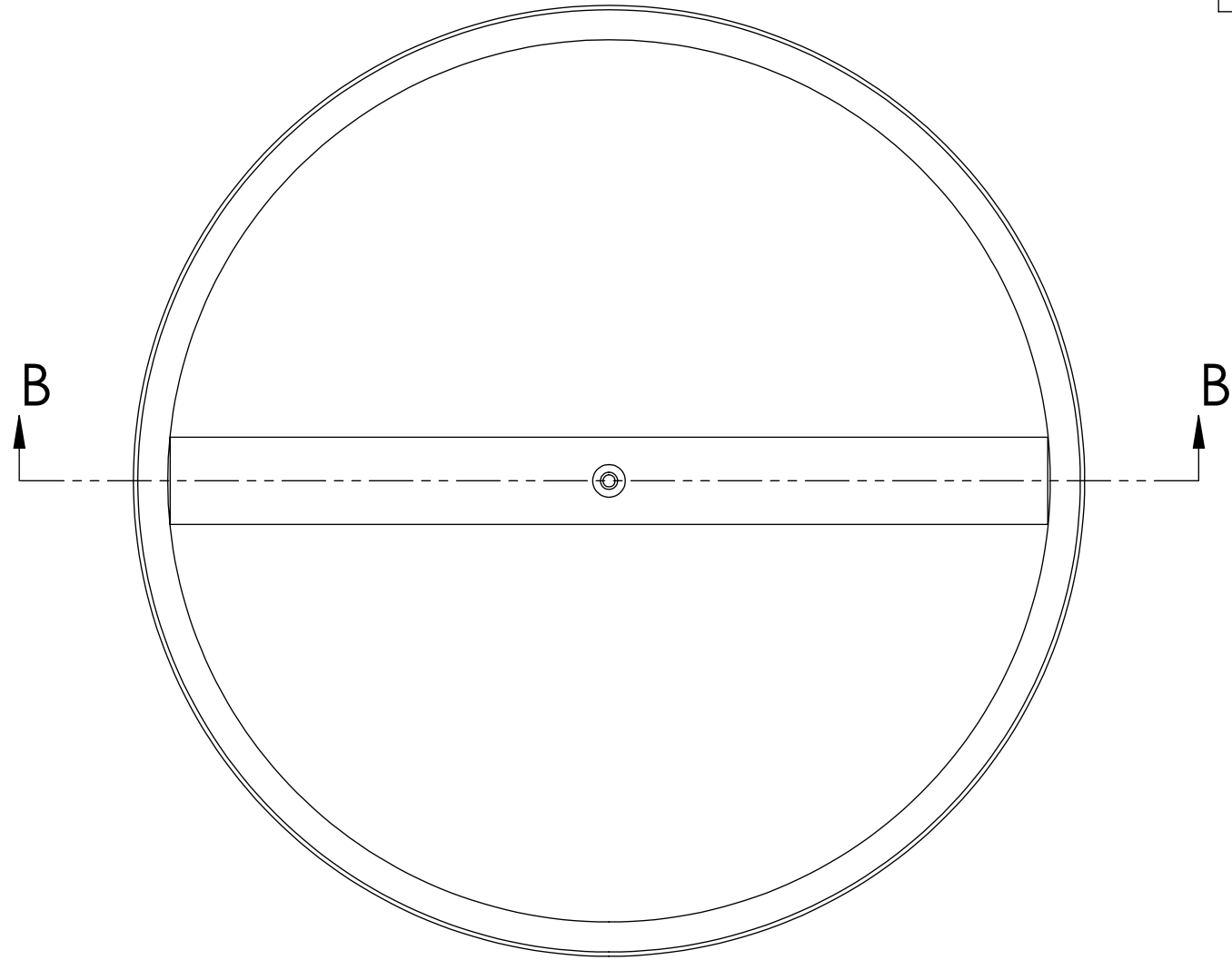

DETAIL A
SCALE 1:1

PAINTED SAFETY YELLOW

USE THIS ASSEMBLY FOR NON-PALLET PAL APPLICATIONS

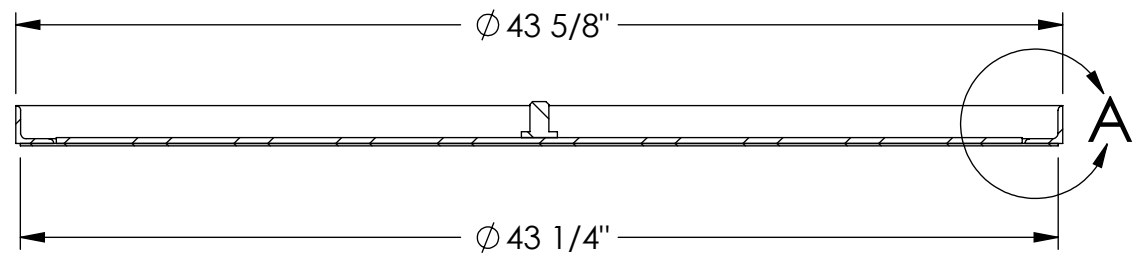

SECTION B-B

ITEM NO.	QTY.	U/M	DESCRIPTION	PART NO.
4		REF	BK-CPC NATCOA 246-Y-61 YEL SFTY	1099001
3		REF	TI INSTR PPAL SOLID TOP WELD PROCEDURE	2980970
2	1	EA	MMP SHT HRS 12GA 43.25D	2998305
1	1	EA	SA PPAL ANGLE RING WM	60000992

Released

3RD ANGLE PROJECTION

PROJECT: -

USE OF PROPRIETARY INFORMATION LIMITED TO WRITTEN AGREEMENT

063Z8 CAGE CODE

FRACTIONS: $\pm 1/8$, $\pm .005$, $\pm .01$
 ANGLES: $\pm .5^\circ$

UNLESS OTHERWISE SPECIFIED, DIMENSIONS ARE IN INCHES

SOUTHWORTH PRODUCTS CORP.
 P.O. Box 1380 Portland Maine 04104-1380

DR KRL DATE 09/10/18
 WT 58.2 LB SCALE 1:8
 REF 3056447

TITLE: ACT TNT TOP WM 43.40D

DWG NO. 60063891

MODEL NON-PPAL
 SHEET 1 OF 1

THIS DRAWING MUST BE AT REVISION 2'

4

3

2

1