

Unit Information

120 volts – 60 Hz – 13 Amp
 Variable Speed From 1,000 to 17,000 Rpm's
 Limited 2 Year Motor Warranty & 1 Year
 Parts and Labor

WARING COMMERCIAL® TORq 2.0 Blender

Variable Speed Control with
 48 oz. Stainless Steel Container

TBB175S4



035299

Control Panel Overlay

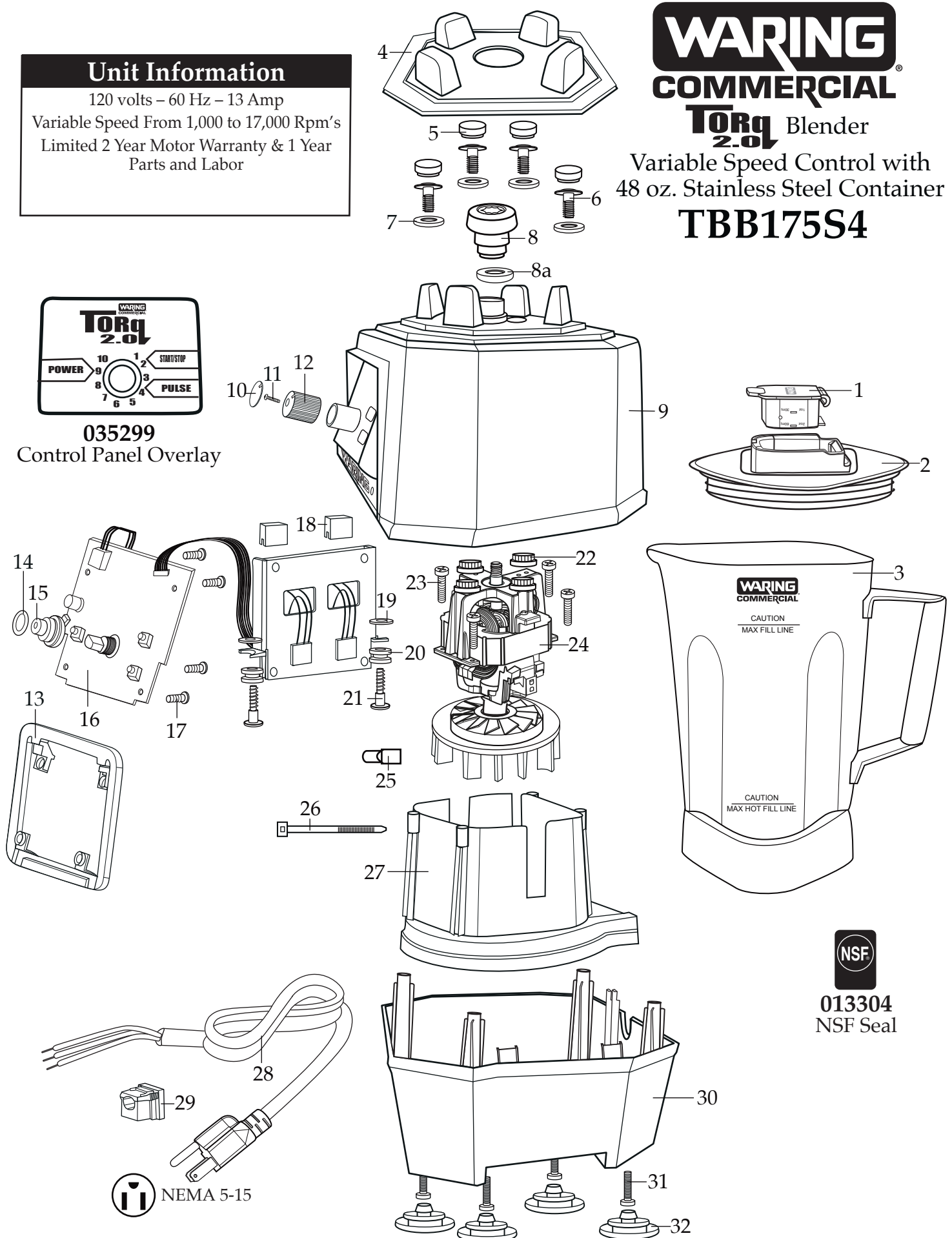

013304
 NSF Seal



NEMA 5-15



Illustration#	Part#	Description
1	035153	Eastman Jar Lid Cover
2	036319-V	Vinyl Jar Cover
3	036320 503515	48 oz. Stainless Steel Container ONLY 48 oz. Stainless Steel Container Complete with Blending Assembly
4	035885	Jar Pad
5	035085	Hole Plug (4 required)
6	034275	Sems (4 required)
7	034273	B Gasket (4 required)
8	037034 035251	Drive Coupling <i>(on units after 11/15/2019)</i> Drive Coupling
8a	037033	Coupling Washer <i>(on units after 11/15/2019)</i>
9	503460-175	Top Housing Assembly
10	035757	Knob Cover
11	026267	Screw
12	036498	Speed Control Knob
13	035237	Back Bezel Control Housing
14	018389	O Ring
15	036499	Speed Control Knob Insert
16	035342	Control Panel
17	035090	Screw (4 required)
18	034900	PCB Cushion (2 required)
19	013604	Washer (2 required)
20	034904	Rubber Pad (2 required)
21	034902	Sems (2 required)
22	034272	A Gasket (4 required)
23	034274	Screw (4 required)
24	034276	ECM Motor
25	012409	Small Crimp Connectors (5 required)
26	013731	Cable Ties (6 required)
27	503483	Motor Housing with Dampeners
28	035124	Cordset
29	033619	Strain Relief
30	503480 035079	Bottom Housing with Feet Bottom Housing ONLY

Illustration# Part# Description

31	034274	Screw (4 required)
32	035088	Foot (4 required)

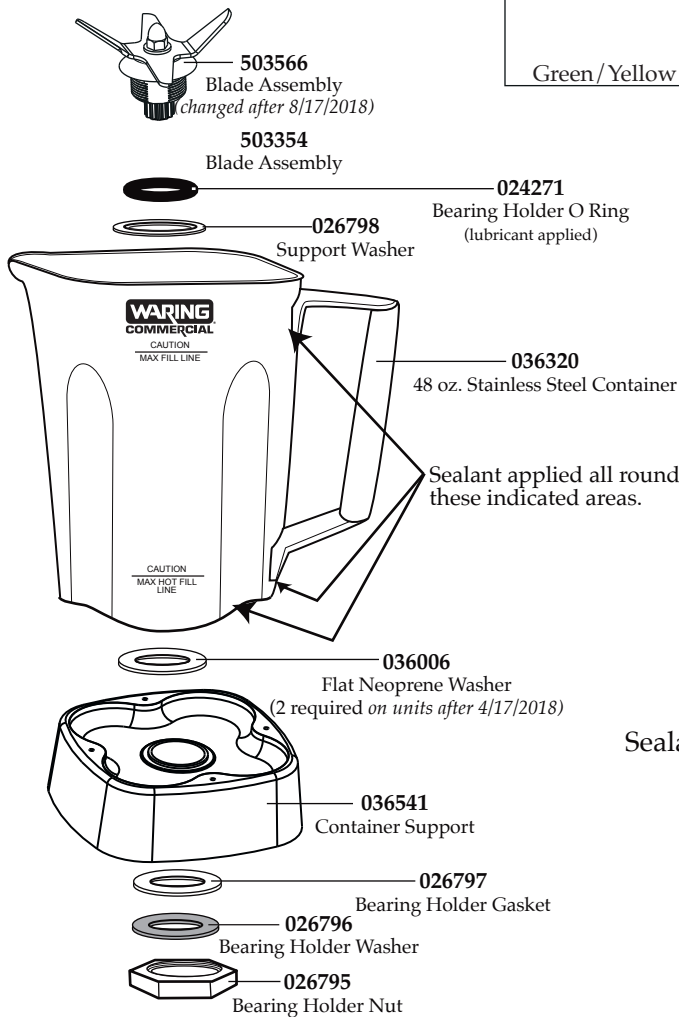
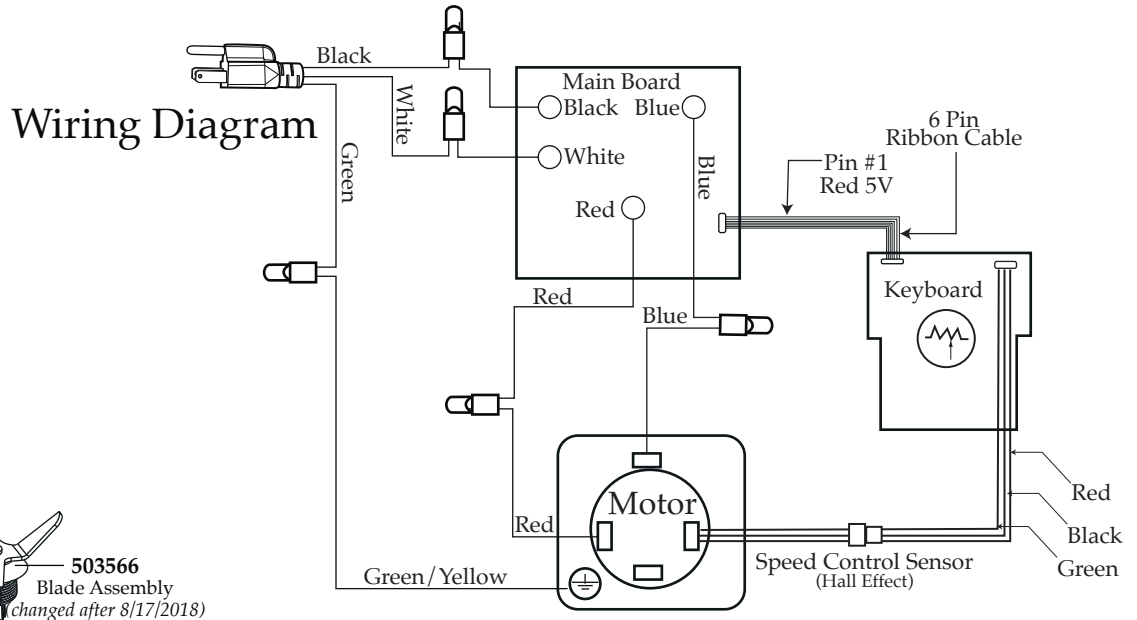

Notes:

Torque 100-125 in/lbs

Sealant applied all around indicated areas.
 Dow Corning Sealant RTV 733

Lubricant applied to O Ring
 Dow Corning 200 (R) Fluid