

Single Wide Locker Assembly

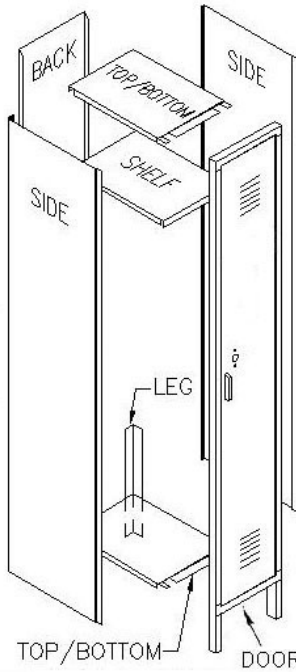

Before Assembly

Please read the complete instructions.

Check for missing or damaged parts.

Only use the specified hardware.

CAUTION: Some parts have sharp edges and corners, wear gloves during assembly.

Assembly will require the following tools:

- 2 drift pins (or 2 nail punches) for hole alignment
- 3/8" socket wrench

Lockers should be assembled on a flat, level surface and anchored according to the instructions found in Section 6.



6-Tier

Double-Tier

Single-Tier

Locker Assembly

1. Bolt together top and bottom with bends facing down and the back with the bends facing up. Top and bottom are identical. For single and double-tier models, bolt hook to back.

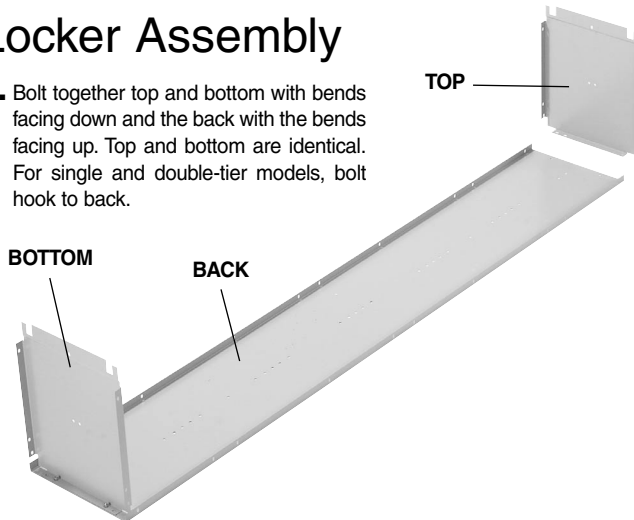

2. Bolt on side with bend in rear and facing in. Omit 2 bolts near bottom rear for legs. Install shelf by bolting to side with bend facing down and 45° bend in front. (See Section 7 Punching Patterns for single, double and 6-tier shelf hole locations.)

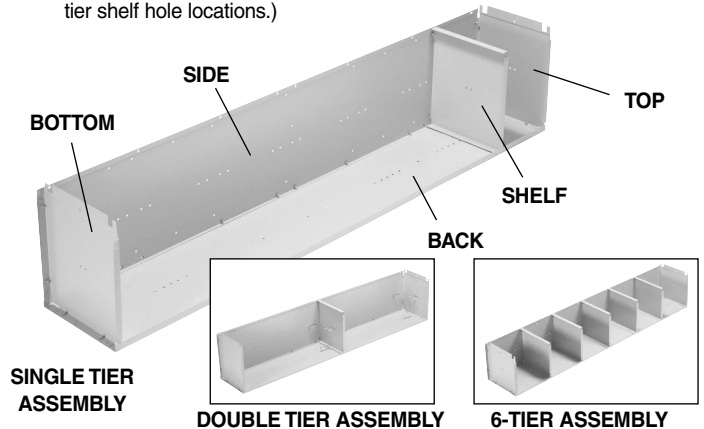

3. Bolt on other side with rear bend facing in.

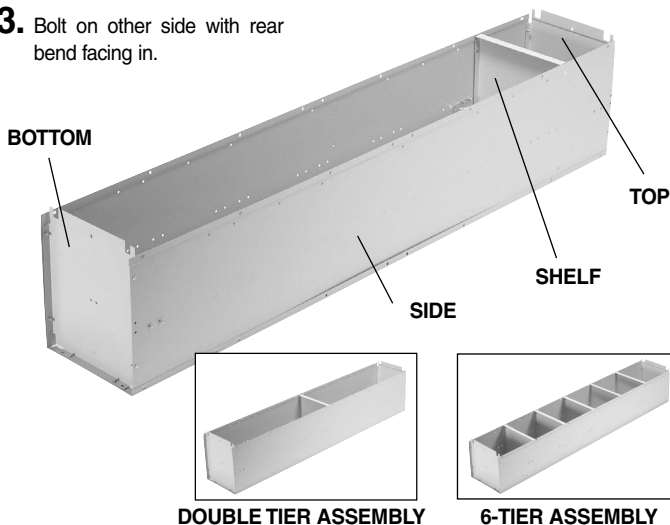

4. Bolt on hooks and/or coat rod

- 18" deep, single-tier lockers include both a coat rod and back and side hooks
- 12" and 15" deep single and double-tier lockers include back, side and top double prong hooks
- Six-tier models do not include coat rods or hooks

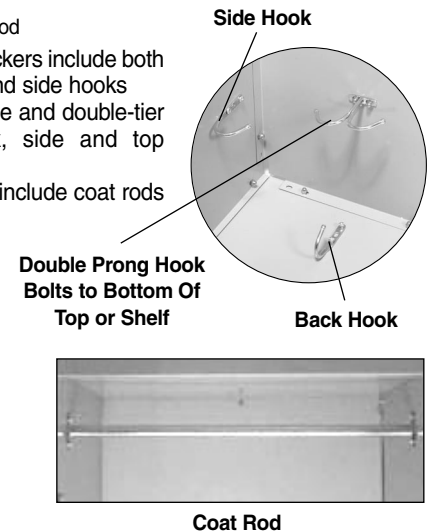
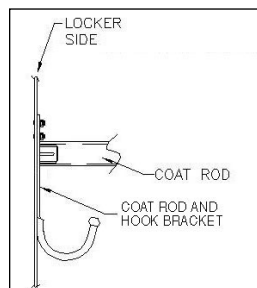

5. Insert rear legs in each end of locker. Bolt each leg in two places.

Attach Door Frame Assembly. Leave top, center and bottom bolts out if attaching to additional lockers.

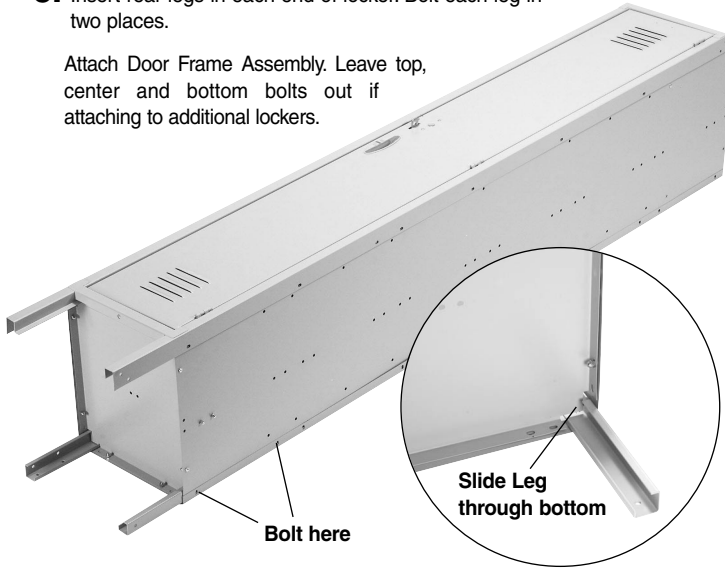

6. Bolt locker foot to leg. Stand locker in place. Level them and adjust rear legs to touch floor and tighten bolts. Bolt banks of lockers together using holes omitted in step #5.

Anchor individual lockers using locker foot on all four legs. Floor anchor not included. For banks of lockers, anchor extreme ends plus intermediate lockers on 36" centers maximum.

For closed base assembly, see instructions included with base.

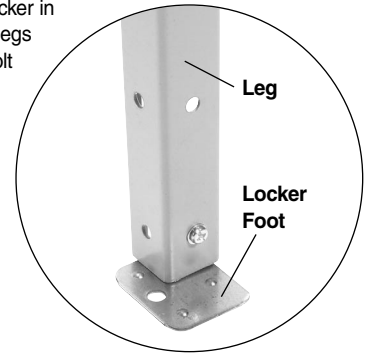

WARNING:
 -FLOOR ANCHOR MUST HAVE A MINIMUM PULL-OUT VALUE OF 190 LBS.
 -WALL ANCHOR MUST HAVE A MINIMUM PULL-OUT VALUE OF 150 LBS.

7. Punching Patterns.

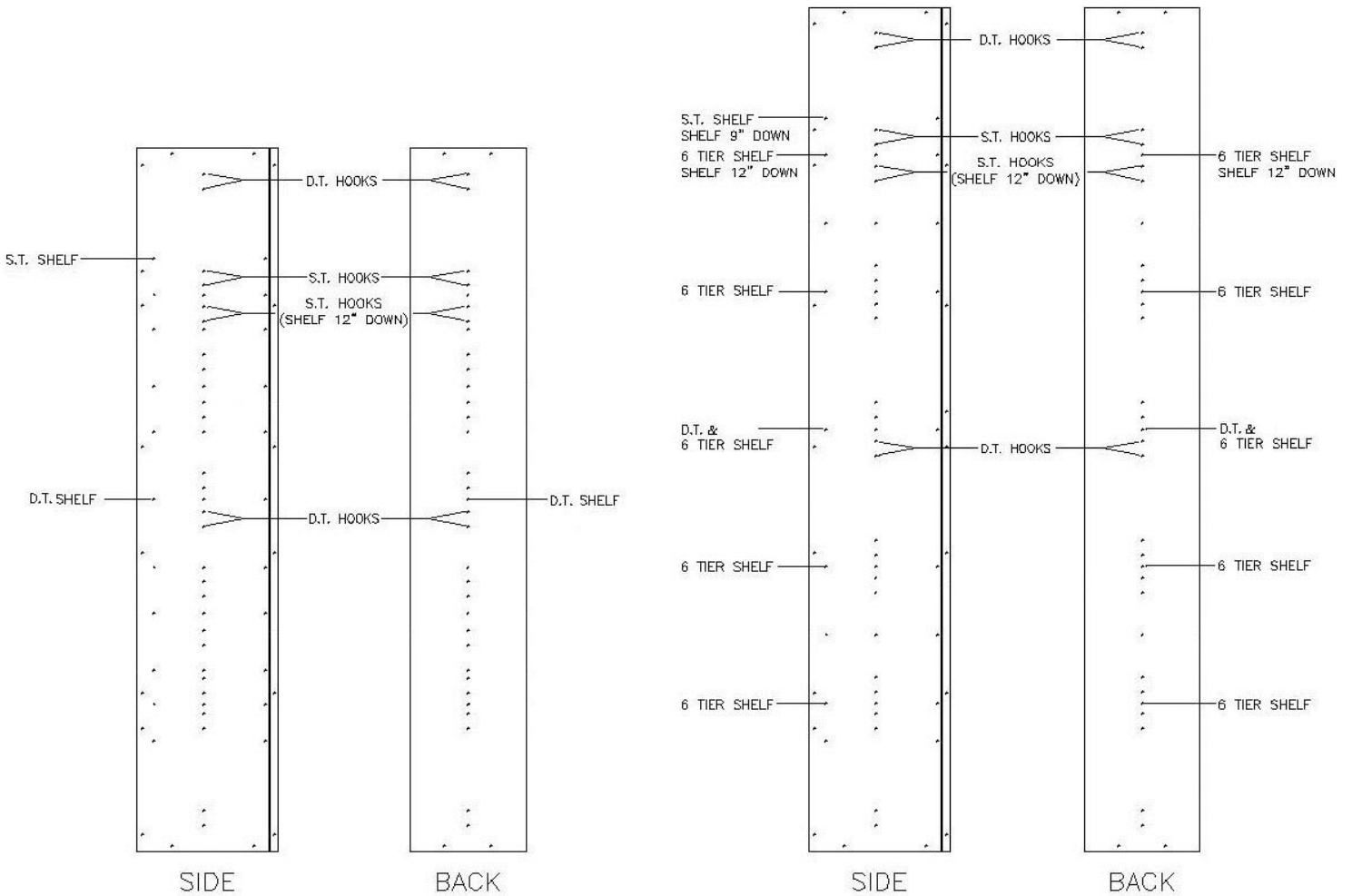

S.T. = Single Tier
D.T. = Double Tier