

PRECISION TOOLS FOR PRECISE PERFORMANCE

Sioux Tools are known around the world for quality, durability and performance. Our extensive array of industrial power tools are engineered and built to make jobs easier, safer and more efficient. Sioux tools are designed to stand up to the demanding



specifications required by today's industrial manufacturing, assembly and finishing needs. Sioux offers a wide array of pneumatic abrasive tools.

Let's take a look.

PNEUMATIC GRINDERS

ABRASIVE SAFETY – A HEADS-UP

Any discussion of grinders requires attention to safety issues. When used improperly or under conditions of wear, grinders can cause serious injury and death. The instructions below should be followed explicitly, but cannot cover all possible situations posing danger. Good judgment is always required.



WEAR PROPER EYE PROTECTION AT ALL TIMES.

This applies both to tool users and to bystanders. Grinders can cause flying particles.

ALWAYS USE AN APPROPRIATE GUARD WHEN GRINDING.

A damaged guard should be replaced with the correct one for the wheel being used.

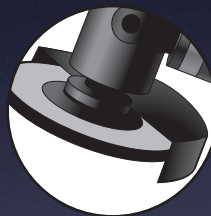

BEFORE MOUNTING, INSPECT GRINDING WHEELS FOR DAMAGE.

Damaged wheels can fracture and break apart, sending debris flying into the work zone. It is therefore important to check the wheel for chips, cracks and other damage. Handle wheels carefully to avoid dropping or bumping, which can cause damage.

PROTECT WHEELS FROM EXTREMES OF TEMPERATURE AND HUMIDITY.

Check wheels after any unusual occurrence that may cause damage to wheels.

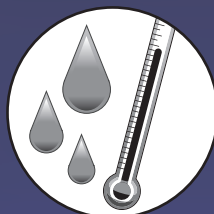

FOLLOW SPEED RATINGS CAREFULLY.

Running abrasive wheels above the rated speed can cause them to fracture and break apart. The speed rating displayed on the wheel must be equal to or greater than the RPM rating on the tool.

SECURE WORK USING CLAMPS OR VISE.

Unsecured work can move violently during grinding and can pose danger.

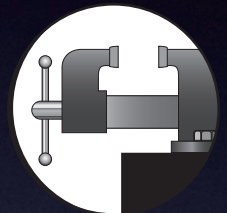

MAKE SURE THE TOOL HAS STOPPED COMPLETELY BEFORE SETTING IT ASIDE.

After the lock-off lever is released, grinders may continue to spin for a short time. Wait for the grinder to stop completely.

BE CERTAIN THAT GRINDER WHEEL AND PARTS ARE ALL IN GOOD CONDITION.

They need to be the proper type and size for the wheel being used. That includes flanges, nuts and related equipment. Also be sure that parts are securely fastened.

SHUT OFF A GRINDER IMMEDIATELY IF THE SOUND CHANGES OR IF IT VIBRATES EXCESSIVELY.

Remove the wheel and check the speed with tachometer.

BE SURE THE LOCK-OFF LEVER IS "OFF" BEFORE CONNECTING AIR.

AVOID BREATHING GRINDER DUST. Use an approved mask.



UNDERSTANDING GOVERNED MOTORS

A governed motor is designed to control the amount of airflow to the motor to keep the RPMs consistent as the wheel contacts the work surface during grinding. The goal of the governor is to provide optimal power consistently, even when the grinder encounters increased loads on the wheel. Governed motors are ideal for larger pneumatic grinders, as they maintain optimal working RPMs to generate more consistent power. Larger grinders can become especially difficult for the operator to handle if not governed.

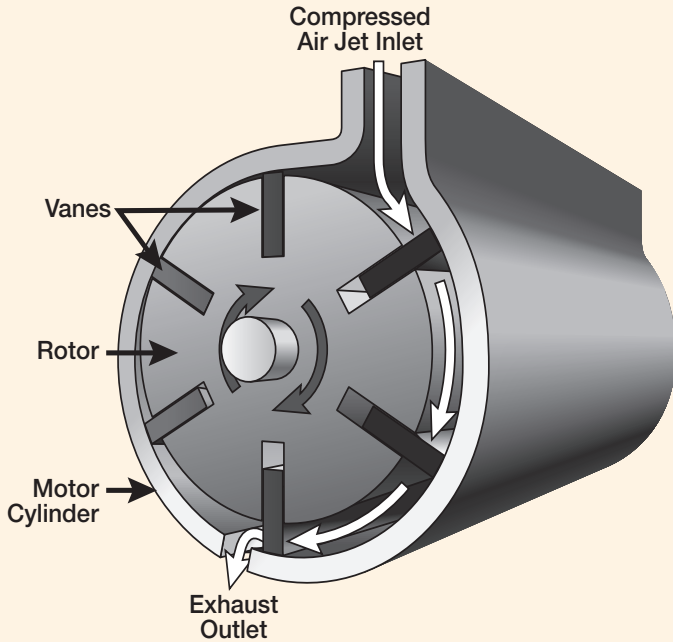

WHEEL CONFIGURATIONS

COATED AND BONDED 'ABRASIVES' – ANOTHER WORD FOR CONSUMABLES USED IN GRINDING

The term 'abrasives' refers to various types of grinding wheels, discs and other specialty configurations that contain abrasive material and remove material during grinding. These abrasives are referred to as either 'coated' or 'bonded.' This distinction describes how the abrasive material is attached to the surface of the grinding wheel during the manufacturing process. The most common coated abrasives are sandpapers, which have layers of abrasive material coated on the belt, disc or sheet. In bonded abrasives, the abrasive grains are held together by a resin or binding agent to form a wheel or stone.

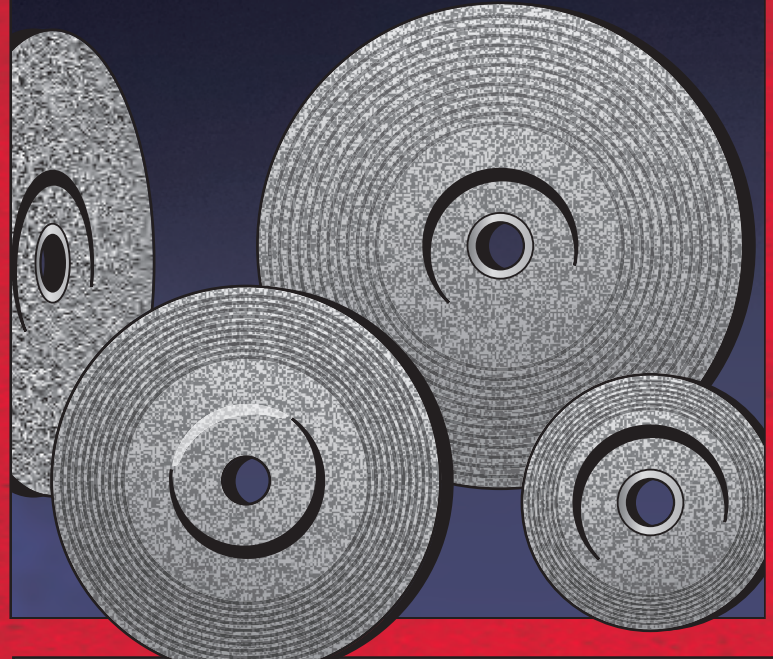

HOW GRINDERS ACTUALLY WORK

Grinders are easy to understand if you think about a wood saw. The saw has a body, and "teeth" that do the cutting. A grinder is similar in function. Instead of a "body," it has a bonding compound that holds "grains" that work something like teeth of a saw for cutting into materials. Instead of creating sawdust, the cutting action of the grinder grains removes small amounts of material that detach from the work surface.

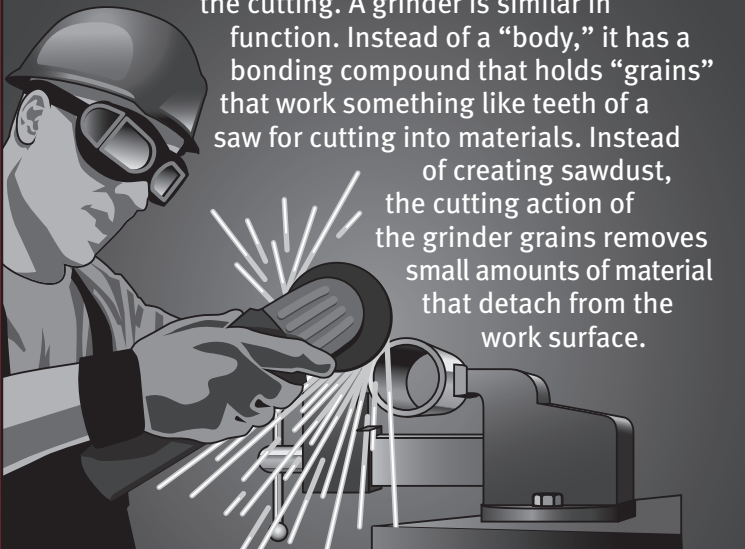

Straight Die Grinders



Angle Die Grinders



Extended Grinders



Die Grinders – Compact grinders that provide maximum accessibility and the fastest speeds. Typically used for higher-precision applications.

Type 27 Wheel Grinders – Mid-size grinders designed to accept industry-standard, "Type 27" abrasive wheels.

Cutoff Tools – Grinders designed to cut material using the abrasive wheel's edge. These abrasive wheels are referred to as "Type 1" wheels.

ANATOMY OF A GRINDER

Housing – Allows the user to have a firm yet comfortable grip. With a great housing, the tool feels like an extension of the body. Many housings conform to the fingers and palm with a comfortable textured feel.

Motor – Transfers power from an incoming jet of air and converts it to rotational power. Motor parts include rotor, rotor blades, cylinder, end plates, and bearings.

Spindle – Mechanical connection point for the abrasive wheel or accessory.

Collar – Clamps down to hold grinder accessories securely to the spindle.

Lever – Controls the flow of pressurized air delivered to the tool and locks off when not actuated.

Wheel – The actual “grinding” component, consisting of abrasive granular material of various hardness, grit size and porosity.

Burrs – cylindrically or spherically shaped cutting tool bits.

Wheel Guard – Safety device that covers the wheel and shields it from the user. ANSI Safety Code specifies that straight wheels, cupped wheels and depressed center wheels must be used with protective wheel guards.

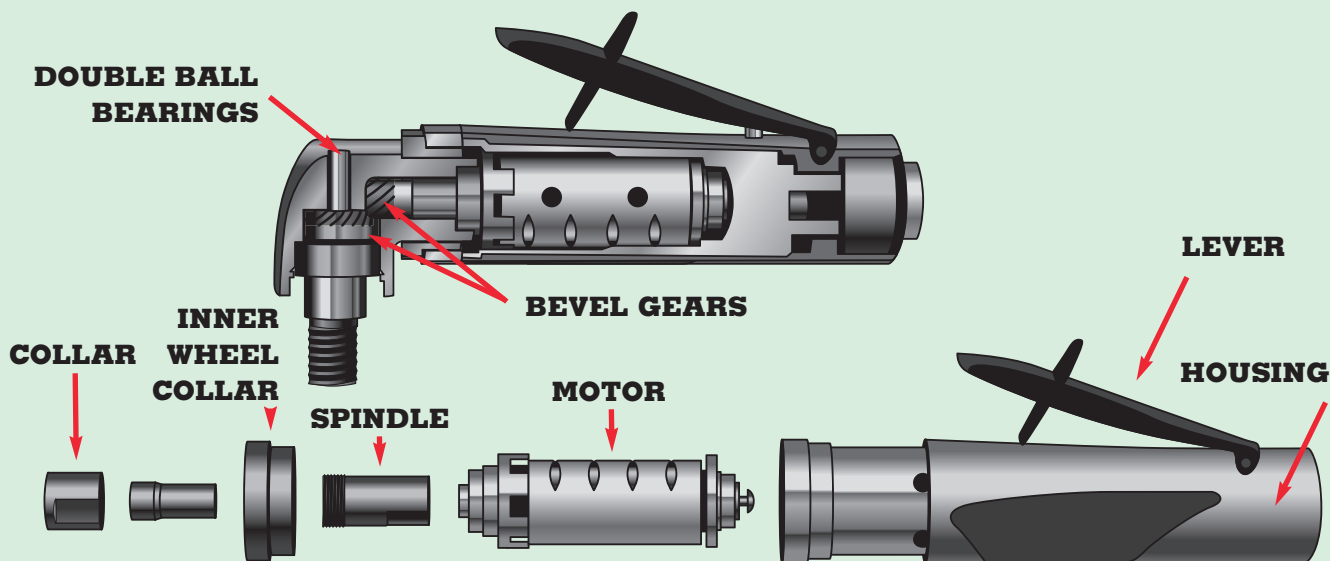

TYPES AND SIZES OF GRINDERS



Type 27 Grinders



Metal Body Grinders

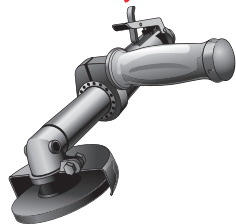

Vertical Grinders

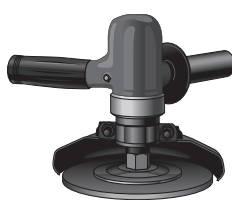

Horizontal Grinders

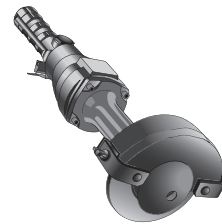

Pencil Grinders



Right Angle or Vertical Grinders – Family of grinders offered in a variety of motor sizes and RPM ranges to cover a broad array of applications. Higher-horsepower sanders feature governed motors. See the section on Governed Motors in this brochure for additional information.

Metal Body Grinders – Heavy-duty grinders made with steel or aluminum bodies for use in extreme environments.

Pencil Grinders – High speed precision tools shaped like a pencil. Typically used for detail work and finishing.

Horizontal Grinders – Family of grinders typically offered at the high-horsepower end of the range and often used with smaller or specialty abrasive wheels. The motor is configured to be horizontal to (or inline with) the abrasive wheel to provide the best control and positioning.

MORE ON ABRASIVE SAFETY

GRIND METALS ONLY IN A SAFE AREA.

The area should be free of combustible or explosive materials or vapors. These conditions can lead to explosions and fire that can cause injury.

KEEP HANDS AND OTHER BODY PARTS AWAY FROM GRINDER PARTS.

Contact with rotating grinding wheels, pads and discs can cause injury from cutting or pinching.

Wear protective clothing including gloves to protect hands.

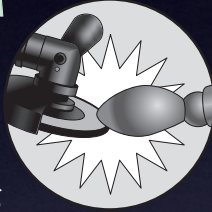

KNOW WHEN TO DISCONNECT GRINDERS

Grinders can start up unexpectedly when connected to an air supply. Before doing any adjustments, maintenance or service – including changing grinding wheels – be sure to do the following:

1. Turn off air supply to the grinder
2. Activate the trigger to release air pressure
3. Disconnect the grinder from the air supply

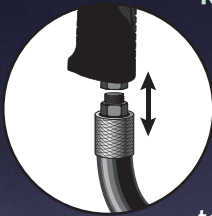

TIGHTEN COLLET SECURELY.

Make sure to match wheel or accessory shaft diameter to chuck or collet. Improperly installed grinding wheels or accessories can spin off the tool and cause injury.

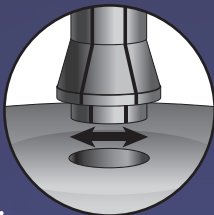

ALWAYS USE THE PROPER TOOL AND ABRASIVE FOR THE JOB.

CHOOSING THE BEST GRINDER FOR THE JOB

Sioux grinders come in many configurations to suit a wide range of applications. The selection of a grinder's quality, configuration, horsepower and speed starts with understanding the specifics of the application:

1. Type of material being removed
2. Shape of the work piece
3. Accessibility issues, if any
4. How often the grinder will be used

ERGONOMICS - DESIGNED FOR USER COMFORT

An ergonomically designed tool can make the job easier and safer. Some Sioux grinders are available with durable and robust steel or aluminum housings and are engineered to perform in harsh environments. Other Sioux grinders are offered with ergonomic, comfort grips and easy-to-handle body styles. These grinders are especially useful when the work requires precision and repeatability, when the work is performed indoors, and when working with wood or laminates.

No matter what the application, know that all Sioux grinders are engineered for optimal performance and built on more than 100 years of pneumatic tool experience.

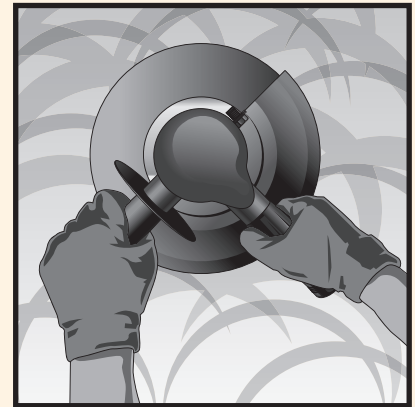

SIoux offers innovative, high quality pneumatic tools for a wide array of industrial manufacturing, assembly and finishing applications.

For an in-depth look at other applications, ask your SIoux salesperson or distributor for our companion brochures.



Snap-on Power Tools, Inc.
250 Snap-on Drive
Murphy, NC 28906

Customer Service: 866-259-7291
Email: sttechsup@siouxtools.com

See the full line of SIoux products:
www.siouxtools.com

SIoux is a trademark, registered in the United States and other countries, of Snap-on Incorporated. Other marks are marks of their respective holders.

© Copyright 2014 Snap-on Incorporated. All rights reserved. Form# ZML0161 • Date:04-14

SIoux Tools Available From:

The information contained herein is for informational purposes only and is not intended to provide instruction or to serve as a training manual. Applications for the tools described herein may vary. Additional and different steps or procedures may be required to properly complete a given task. Always wear safety glasses when operating power tools.