

SELECTING THE BEST CLUTCH FOR YOUR APPLICATION

DIRECT DRIVE

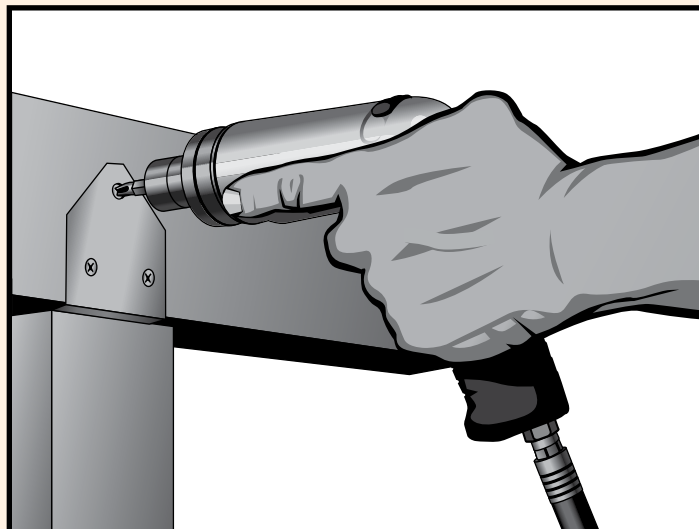

Application: Driving long wood screws

POSITIVE CLUTCH

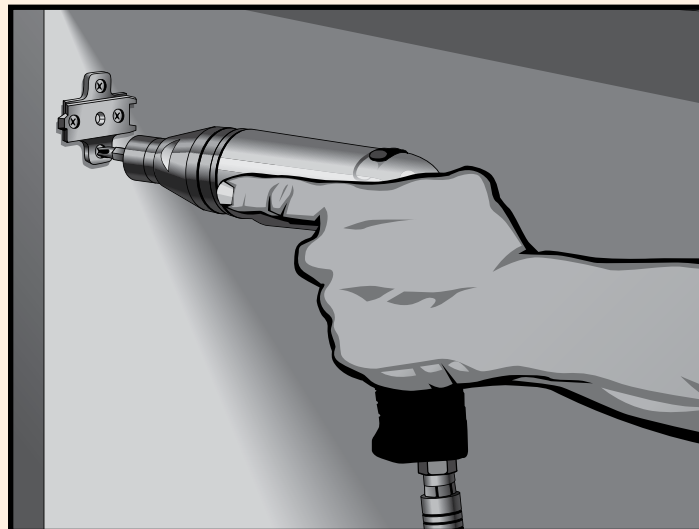

Application: Assembling cabinetry

ADJUSTABLE CLUTCH

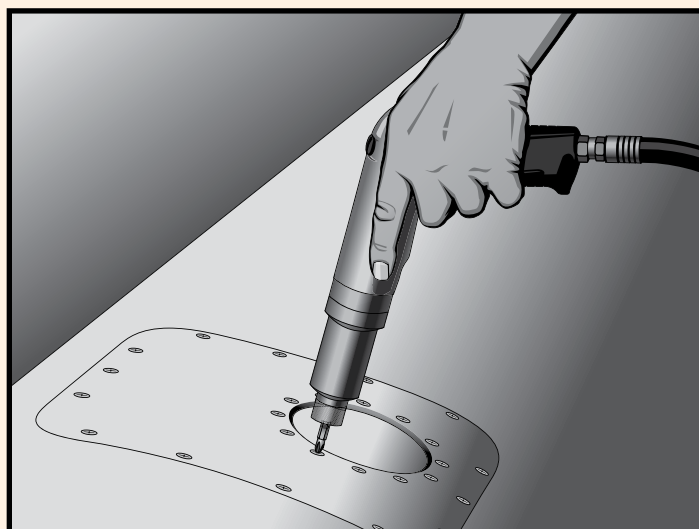

Application: Joining layers of sheet metal

TORQUE CONTROL



Application: Securing an electronic board to blind holes in a plastic frame

#4 in an
Education Series

KNOWLEDGE IS POWER

Everything you need to know about pneumatic screwdrivers

PRECISION TOOLS FOR PRECISE PERFORMANCE

Sioux Tools are known around the world for quality, durability and performance. Our extensive array of industrial power tools are engineered and built to make jobs easier, safer and more efficient. Sioux tools are designed to stand up to the demanding



specifications required by today's industrial manufacturing, assembly and finishing needs. Sioux offers a wide array of pneumatic screwdrivers.

Let's take a look.

PNEUMATIC SCREWDRIVERS

A HEADS-UP ABOUT SAFETY

Any discussion of screwdrivers should begin with an understanding of safety. While these tools have amazing capabilities, certain precautions should be followed without exception.



KEEP THE EYES PROTECTED: YOURS AND THOSE AROUND YOU.

Driving screws can cause safety hazards: Screws can break off and become airborne. Similarly, small pieces of material can detach from the work surface and become airborne. These fragments can cause damage, so it is essential that the operator and those in the surrounding area wear proper eye protection at all times.

BROKEN BITS AND ADAPTORS CAN CAUSE INJURY.

Proper eye protection must be worn at all times by tool users and bystanders. Use only bits and adaptors that are made for power tools and that are in good condition. Keep hands away from bits and adaptors.

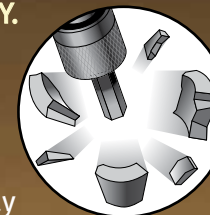

MAINTAIN A SOLID BODY POSITION AND SECURE FOOTING.

Pneumatic screwdrivers operate on a high level of power. Sudden and unexpected screwdriver movements can happen and cause injury. The operator needs to maintain control of the screwdriver, which requires a little knowledge of physics and a lot of common sense. The body should be well positioned with secure footing when operating a pneumatic screwdriver.

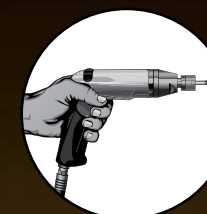

KNOW HOW AND WHEN TO DISCONNECT SCREWDRIVERS.

Screwdrivers can start up unexpectedly when connected to an air supply. Before doing any maintenance, service or adjustments – including changing accessories – be sure to do the following:



- Turn off air supply to the screwdriver



- Activate the trigger to release air pressure



- Disconnect the screwdriver from the air supply

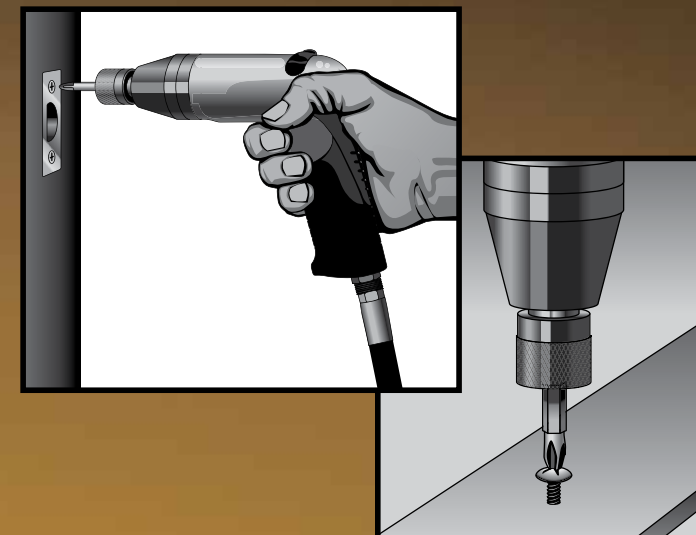

SIoux offers innovative, high quality pneumatic tools for a wide array of industrial manufacturing, assembly and finishing applications.

For an in-depth look at other applications, ask your SIoux salesperson or distributor for our companion brochures.

Snap-on Power Tools, Inc.
250 Snap-on Drive
Murphy, NC 28906

Customer Service: 866-259-7291
Email: sttechsup@siouxtools.com

See the full line of SIoux products:
www.siouxtools.com

SIoux is a trademark, registered in the United States and other countries, of Snap-on Incorporated. Other marks are marks of their respective holders.

© Copyright 2014 Snap-on Incorporated. All rights reserved. Form# ZML0162 • Date:05-14

SIoux Tools Available From:

The information contained herein is for informational purposes only and is not intended to provide instruction or to serve as a training manual. Applications for the tools described herein may vary. Additional and different steps or procedures may be required to properly complete a given task. Always wear safety glasses when operating power tools.

HOW PNEUMATIC SCREWDRIVERS WORK – THE BASICS

A pneumatic screwdriver is powered by compressed air. Inside the screwdriver, the compressed air is directed over the vanes of the screwdriver motor, rotating the motor and providing the energy needed to power the screwdriver when in use. A gear reduction system adjusts this output to an appropriate RPM range and torque level for the application.

This power is then managed by a clutch. There are 4 basic types of pneumatic screwdriver clutches: **direct drive**, **positive**, **adjustable** and **torque control**. Selection of the appropriate clutch depends on the application and is covered in more detail in this guide.

The spindle holds the screwdriver bit or other accessories for driving a variety of fasteners. How do you know which type of screwdriver to use? The application determines the appropriate screwdriver selection. Key factors include the type of surface material and the sizes and types of fasteners being driven. Look for screwdriver specs when making a selection, including motor output torque, free-speed RPM, and clutch type.

ANATOMY OF A SCREWDRIVER

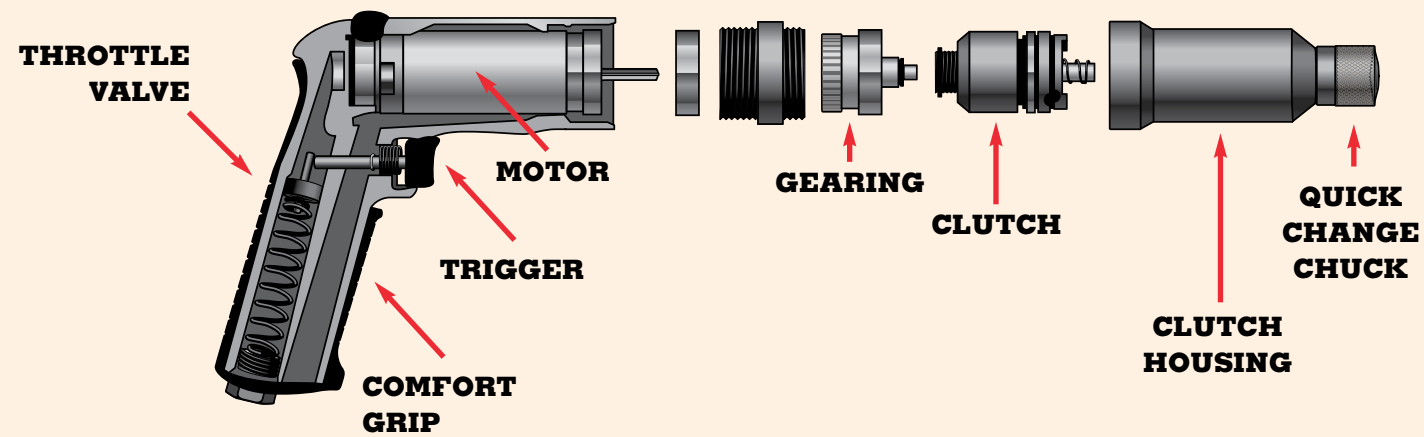

BASIC TYPES OF PNEUMATIC SCREWDRIVER CLUTCHES

1 Direct Drive:

- Simple and low maintenance clutch design
- Low cost
- Power is transferred directly from the motor to the spindle
- Operator input is critical in preventing over-torquing

2 Positive Clutch:

- Clutch is engaged only when the operator pushes the tool toward the work surface
- Clutch will disengage when motor's maximum torque is reached or when operator stops pushing

3 Adjustable Clutch:

- Torque is set by increasing / decreasing tension on the tool's spring-loaded clutch
- Clutch will disengage and an audible sound will be heard when torque setting is reached

4 Torque Control:

- Most accurate torque configuration
- Two-cam clutch configuration stops the air supply to the motor when torque setting is reached
- Torque is set by adjusting the tool's spring-loaded clutch

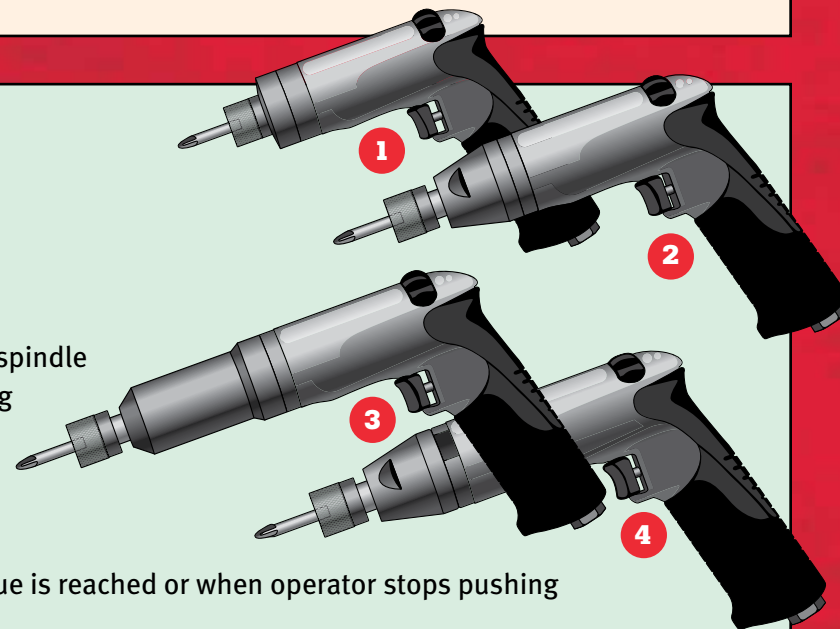

SERVICEABILITY

Sioux Tools Makes It Easy – Serviceability is a key factor in managing operating costs for production tools, and also in maintaining optimal performance. Sioux Tools engineers its screwdrivers with serviceability and total cost of ownership in mind. See the following illustration below for a few detailed examples:

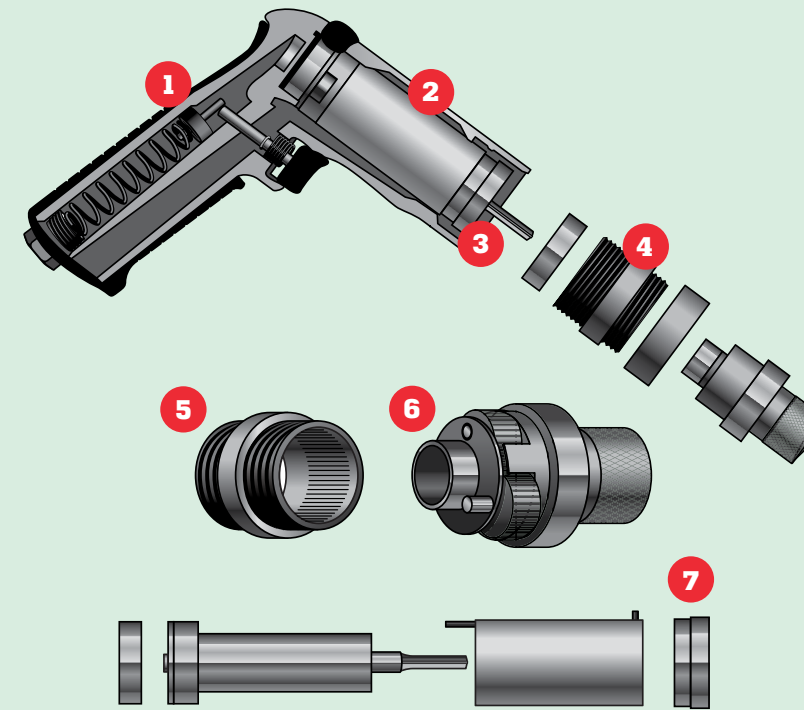

- 1 Tipper valve and valve seat are easily accessible.
- 2 Drop-in motors can be easily replaced.
- 3 Rotor pinion is case hardened to resist wear.
- 4 Grease zerk allows convenient lubrication without disassembly.
- 5 Ring gear is integrated with motor retainer. Machined-in design makes assembly and disassembly easy.
- 6 Planetary gear pins are slip-fit designed for easy assembly and disassembly.
- 7 Front endplate bearing is slip-fit designed for easy access to the motor without disturbing rotor spacing.

The use of many interchangeable parts reduces stocking requirements for spare parts and cribs.

GETTING A HANDLE ON SCREWDRIVER MAINTENANCE

The parts above need regular inspection, cleaning and lubrication. Contact your Sioux representative for specific details.

Sioux offers innovative, high quality pneumatic tools for a wide array of industrial manufacturing, assembly and finishing applications. Please contact your distributor to discuss your specific needs.

For an in-depth look at other applications, ask your Sioux salesperson or distributor for Sioux companion brochures.

SELECTING THE BEST SCREWDRIVER FOR THE JOB

It is critical to select the ideal pneumatic screwdriver for the application. Several factors may come into play:

- What is being assembled?
- What material is involved?
- What type of screw or nut is being driven?
- What screw size?
- What torque and what tolerance?
- Will the material pull up when driving screws?
- What is the production rate?
- Are there accessibility issues?
- What handle style is needed?
- Does the tool need to be reversible?
- What drive type is needed?

Based on the answers to the questions above, one or more screwdriver types will emerge as optimal candidates. Typically, selecting a screwdriver with the right power and RPM for a given job is fairly straightforward. Choosing the

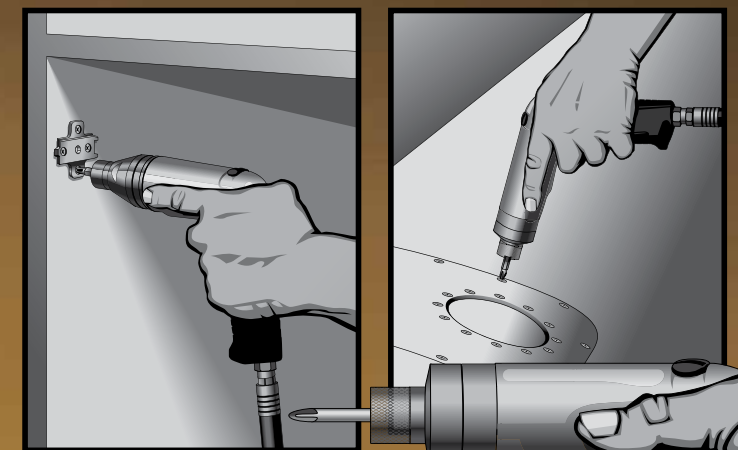

appropriate clutch is the more critical and challenging task. See the next page and let's focus on how to select the best clutch for your application.