

THE THOUGHTFUL SOLUTION FOR THOSE WITH SPECIAL NEEDS.



ADULT EXTENDED RECESSED 100SSE-R
Global Industrial Item Number B2311698

- Durable, bacteria resistant tray
- ADA and ANSI compliant when properly installed
- Made in the USA
- Easy-to-clean safety strap that adjusts with one hand
- Limited 5 year warranty
- Supports 400 lbs



BABY CHANGERS MADE BY BABY EXPERTS.™



5216 Portside Dr • Medina, OH 44256, U.S.A.
Public Washroom Sales Manager
Phone: 330-723-9814

www.foundations.com/changing-stations.html



BABY CHANGERS MADE BY BABY EXPERTS.™

Submittal Sheet

Model 100SSE-R Special Needs Stainless Steel Diaper Changing Station

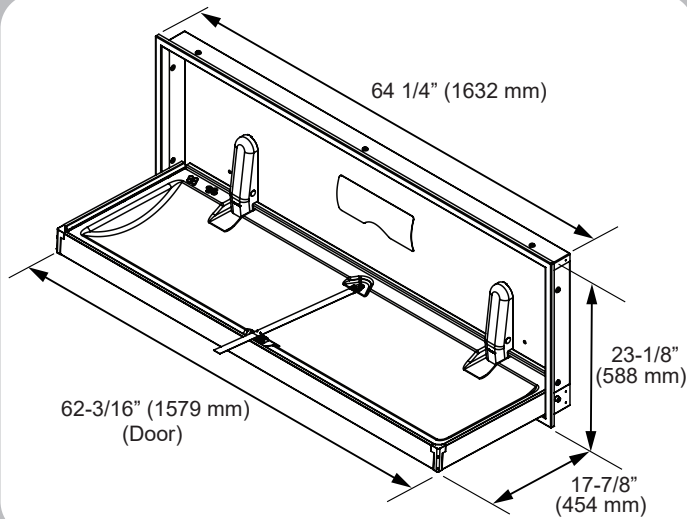

- Full body 16 gauge, 304 brushed stainless steel.
- ABS replaceable tray liner.
- Rated to support a static load of 400 pounds (181 kg).
- Adult or physically challenged changing station ideal for schools, nursing homes and hospitals.
- Smooth nylon belt with Thermoplastic Polyurethane coating. Easy to sanitize and adjustable with one hand.
- Full stainless steel frame and hinges provide maximum durability.
- Easy to read ANSI compliant labels (ANSI Z535.3 and ANSI Z535.4), utilizing universal safety symbols.
- Pneumatic gas shock mechanisms to ensure smooth, safe open and close motions.
- Includes universal changing station door sign.
- Universal changing station plaque on front of unit.
- Extended length of 62-3/16" inches (1579 mm).
- Limited Warranty: This product is warranted against manufacturing defects for a period of 5 years.

Recommended Blocking Recessed Mount

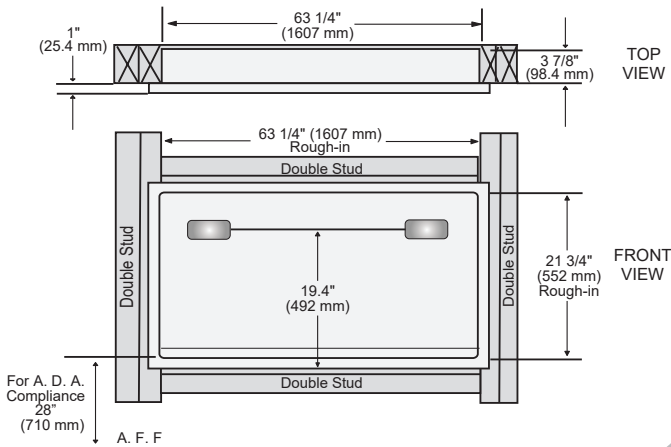

Short Specifications

Full 304 brushed stainless steel exterior with vacuum formed polystyrene changing surface.

1. A.D.A Compliant attached buckle.
2. Acceptable product: Foundations Worldwide, Inc.; Model 100SSE-R (Horizontal Recessed Mount).
3. Characteristics:
 - a. Entire body 16 gauge, 304 brushed stainless steel, seamless welds.
 - b. Provide Foundations Worldwide, Inc. 200-SSLD; stainless steel liner dispenser.
4. Equipped with pneumatic cylinders.
5. Smooth nylon belt with Thermoplastic Polyurethane coating. Easy to sanitize and adjustable with one hand.
6. 400 lb. (181 kg) load rating exceeds ASTM F2285 requirements for weight bearing changing stations.
7. **A.D.A. Compliance:**

306.3	Knee Clearance
307.2	Maximum Protruding Objects
308.2	Forward Reach
308.3	Side Reach
309.4	Operation
902.3	Work Surface

Compliant when properly installed.
8. ANSI compliant safety labels.
9. CPSIA compliant to applicable sections.

Installation Information

- 3.88 inches (98 mm) recessed into wall, 1 inch (25 mm) protrusion from wall.
- Rough-in opening 63.25 inches (1607 mm) wide x 21.75 mm (552 high). Shim as required for tight fit on all 4 sides. For recess mount, use side mounting holes.
- Open unit project from wall 17.875 inches (454 mm).

