

# THE THOUGHTFUL SOLUTION FOR THOSE WITH SPECIAL NEEDS.



ADULT EXTENDED RECESSED 100SSE-SM  
**Global Industrial Item Number B2311695**

- Durable, bacteria resistant tray
- ADA and ANSI compliant when properly installed
- Made in the USA
- Easy-to-clean safety strap that adjusts with one hand
- Limited 5 year warranty
- Supports 400 lbs



BABY CHANGERS MADE BY BABY EXPERTS.™



5216 Portside Dr • Medina, OH 44256, U.S.A.  
Public Washroom Sales Manager  
Phone: 330-723-9814

[www.foundations.com/changing-stations.html](http://www.foundations.com/changing-stations.html)



BABY CHANGERS MADE BY BABY EXPERTS.™

# Submittal Sheet

## Model 100SSE-SM Special Needs Stainless Steel Diaper Changing Station

- Full body 16 gauge, 304 brushed stainless steel.
- ABS replaceable tray liner.
- Rated to support a static load of 400 pounds (181 kg).
- Adult or physically challenged changing station ideal for schools, nursing homes and hospitals.
- Smooth nylon belt with Thermoplastic Polyurethane coating. Easy to sanitize and adjustable with one hand.
- Full stainless steel frame and hinges provide maximum durability.
- Easy to read ANSI compliant labels (ANSI Z535.3 and ANSI Z535.4), utilizing universal safety symbols.
- Pneumatic gas shock mechanisms to ensure smooth, safe open and close motions.
- Includes universal changing station door sign.
- Universal changing station plaque on front of unit.
- Surface mount requires additional flange. Specify model 100SSE-SM.
- Extended length of 62 inches (1575 mm).
- Limited Warranty: This product is warranted against manufacturing defects for a period of 5 years.

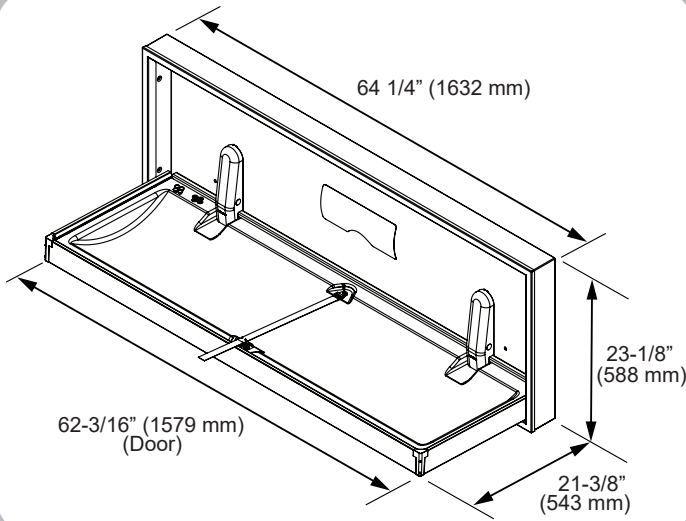

### Recommended Blocking Surface Mount

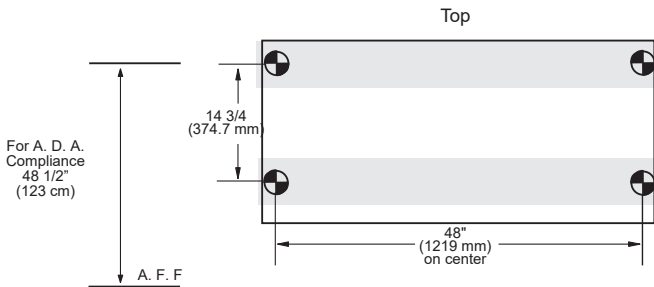

### Installation Information

- Unit projects 4 inches (100 mm).
- Rough-in opening 63.25 inches (1607 mm) wide x 21.75 inches (552 mm) high. Shim as required for tight fit on all 4 sides.
- Open unit project from wall 21.375 inches (543 mm).

### Short Specifications

Full 304 brushed stainless steel exterior with vacuum formed polystyrene changing surface.

1. A.D.A Compliant attached buckle.
2. Acceptable product: Foundations Worldwide, Inc.; 100SSE-SM (Horizontal Surface Mount).
3. Characteristics:
  - a. Entire body 16 gauge, 304 brushed stainless steel, seamless welds.
  - b. Provide Foundations Worldwide, Inc. 200-SSLD; stainless steel liner dispenser.
4. Equipped with pneumatic cylinders.
5. Smooth nylon belt with Thermoplastic Polyurethane coating. Easy to sanitize and adjustable with one hand.
6. 400 lb. (181 kg) load rating exceeds ASTM F2285 requirements for weight bearing changing stations.
7. **A.D.A. Compliance:**
  - 306.3 Knee Clearance
  - 307.2 Maximum Protruding Objects
  - 308.2 Forward Reach
  - 308.3 Side Reach
  - 309.4 Operation
  - 902.3 Work Surface

Compliant when properly installed.
8. ANSI compliant safety labels.
9. CPSIA compliant to applicable sections.

